

# Operation Manual

**COLOR INKJET PRINTER**

***JV400-SUV Series***

***SUJV-160***

**Operation manual**

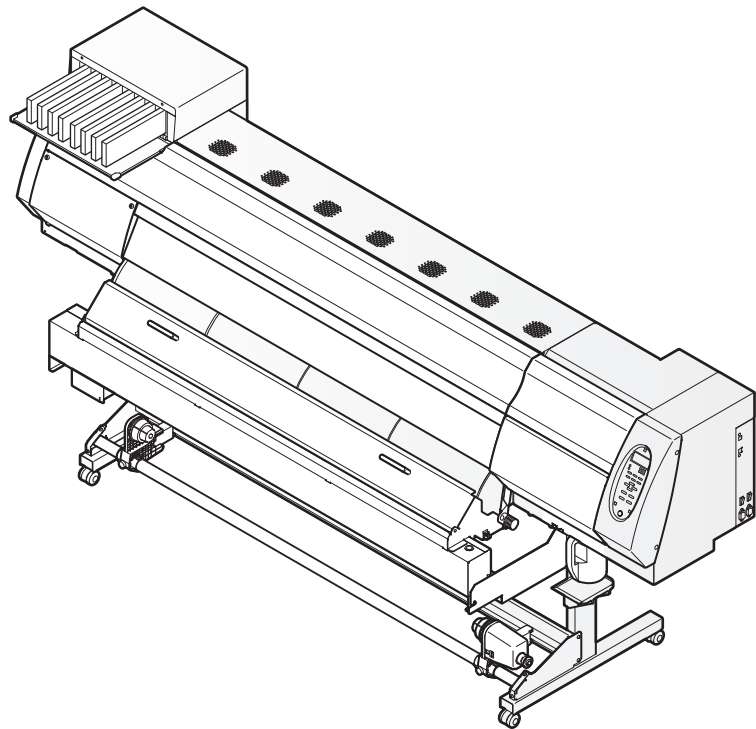

**MIMAKI ENGINEERING CO., LTD.**

<https://mimaki.com/>

# TABLE OF CONTENTS

---

Foreword .....	v
DISCLAIMER OF WARRANTY .....	v
Requests .....	v
FCC Statement (USA) .....	v
Interference to televisions and radios .....	v
About usable ink .....	vi
About usable media .....	vi
On This Operation manual .....	vi
Safety Precautions .....	vii
Symbols .....	vii
Safety interlock .....	xi

## Chapter 1 Before Use

Moving This Machine .....	1-2
Where to Install This Machine .....	1-2
Working Environmental Temperature .....	1-2
Moving This Machine .....	1-3
Names of Parts and Functions .....	1-4
Front Side of the Machine .....	1-4
Rear Side and Right Side of the Machine .....	1-5
Operation Panel .....	1-6
Heater .....	1-7
Media sensor .....	1-7
Carriage .....	1-8
Cutter blade and slot for cutting .....	1-8
Capping station .....	1-9
Pinch rollers and Feed rollers .....	1-9
Connecting Cables .....	1-10
Connecting USB2.0 Interface Cable .....	1-10
Connecting the power cable .....	1-11
Inserting ink cartridges .....	1-12
Caution in handling of ink cartridges .....	1-12
Insert an ink cartridges .....	1-13
Changing an ink cartridge .....	1-14
For Ink cartridge lamps .....	1-14
Restrictions concerning the product .....	1-14
About cartridge ink end and ink near end .....	1-14
How to assemble ink cartridge .....	1-15
Media .....	1-17
Usable sizes of media .....	1-17
Caution in handling of medias .....	1-17
About antistatic sheet .....	1-19

## Chapter 2 Basic Operations

Workflow .....	2-2
Turning the Power ON/OFF .....	2-3
Turning the Power ON .....	2-3
Turning the Power OFF .....	2-4
Setting a Media .....	2-5

Adjusting the Head Height .....	2-5
Note for media setting .....	2-7
Setting a roll media .....	2-8
Take-up device .....	2-12
Changing the printing origin .....	2-13
Preparing for the Heaters .....	2-14
Changing the Temperature Settings for the Heaters .....	2-14
Checking the Heater Temperature .....	2-15
Test Feeding .....	2-16
Test Printing .....	2-17
Test Printing .....	2-18
Head Cleaning .....	2-19
About head cleaning .....	2-19
Perform head cleaning depending on the test printing result .....	2-19
Set the media feeding .....	2-20
Setting Feed Correction .....	2-20
Correct the ink drop position for bidirectional printing .....	2-22
Printing Data .....	2-24
Starting a Printing Operation .....	2-24
Stopping a printing operation halfway .....	2-25
Deleting Received Data (Data Clear) .....	2-25
Behavior after printing has been completed .....	2-25
Cutting a media .....	2-27

### **Chapter 3      Extended Functions**

List of Functions .....	3-2
Setting Logical Seek .....	3-3
Setting Drying Time .....	3-5
Setting Margins .....	3-6
Perform setting to reduce stripes between passes .....	3-7
Setting Auto Cleaning .....	3-8
Setting nozzle face cleaning time .....	3-9
Other Settings .....	3-10
Machine Settings .....	3-11
Setting a AUTO Power-off .....	3-13
Setting the Display of Media Residual .....	3-14
Adjusting the Remaining Amount in the Ink Cartridge .....	3-17
Setting Time .....	3-22
Setting Units .....	3-23
Setting a KEY BUZZER .....	3-24
Set the network .....	3-25
Setting event mail function .....	3-27
Setting a LANGUAGE .....	3-36
Initializing the Settings .....	3-37
Confirming Machine Information .....	3-38
Displaying the Information .....	3-38
Check such as the machine version information .....	3-40
Displaying the Information of this machine .....	3-41

## Chapter 4 Maintenance

Maintenance .....	4-2
Precautions for Maintenance .....	4-2
About Cleaning Solution .....	4-2
Maintenance .....	4-2
Cleaning the Exterior Surfaces .....	4-3
Cleaning the Platen .....	4-3
Cleaning of after heater cover and pre heater cover .....	4-4
Cleaning the Media Sensor .....	4-4
Cleaning the Media Holder .....	4-5
Maintaining the Capping station .....	4-6
Cleaning the Wiper and Cap .....	4-6
Washing the Ink Discharge Passage (DISWAY WASH) .....	4-12
When the Machine Is Not Used for a Long Time (CUSTODY WASH) .....	4-13
NOZZLE PROTECT function .....	4-16
Cleaning the Head and the Area around It (every day) ...	4-19
Replacing method of C absorber kit .....	4-21
When Nozzle Clogging Cannot Be Solved .....	4-23
Washing of Head nozzle .....	4-23
When nozzle missing occurs due to ink mixture or aeration .....	4-26
Alternative nozzles for printing, when nozzles missing can not be im- proved .....	4-28
Automatic Maintenance Function .....	4-31
Setting the Refreshing Intervals .....	4-31
Setting the Cleaning Intervals .....	4-32
Setting the Disway wash Intervals .....	4-33
Replacing consumables .....	4-34
Replacing the wiper .....	4-34
If a Waste Ink Tank Confirmation Message Appears .....	4-35
Replacing the waste ink tank before the waste ink tank confir- mation message is displayed .....	4-38
Replacing the Cutter Blade .....	4-39
Checking UV ink curing level .....	4-41

## Chapter 5 Troubleshooting

Troubleshooting .....	5-2
Power does not turn on .....	5-2
The machine does not start printing .....	5-2
Media get jammed / media is soiled .....	5-3
[HEAT] or [CONSTANT] LED does not light up .....	5-3
Image quality is poor .....	5-4
Nozzle is clogged .....	5-4
Ink cartridge warning appears .....	5-5
“Check Ink Pack” appears .....	5-6
When the INK REMAIN Setting Message is Displayed .....	5-7
When Error 618 to 61b occur .....	5-8
If negative pressure abnormality occurs .....	5-9
When media heaves up at feeding .....	5-11
When the feeding media is loosened and reached to the floor .....	5-11

---

Warning / Error Messages .....	5-12
Warning messages .....	5-12
Error messages .....	5-15

## **Chapter 6      Appendix**

Specifications .....	6-2
Machine specifications .....	6-2
Ink specifications .....	6-3
Setting orders depending on ink type .....	6-4
Setting orders of ink cartridges .....	6-4
Sheet for inquiry .....	6-5
Warning labels .....	6-6
Function Flowchart .....	6-8

# Foreword

Congratulations on your purchase of MIMAKI color ink jet printer "JV400 SUV Series", "SUJV-160". "JV400 SUV Series", "SUJV-160" (called as this machine hereafter) is a color inkjet printer that can print with solvent UV ink realizing high image quality.  
If there is no caution statement, "JV400SUV series" and "SUJV-160" have common specifications.

## DISCLAIMER OF WARRANTY

THIS LIMITED WARRANTY OF MIMAKI SHALL BE THE SOLE AND EXCLUSIVE WARRANTY AND IS IN LIEU OF ALL OTHER WARRANTIES, EXPRESS OR IMPLIED, INCLUDING, BUT NOT LIMITED TO, ANY IMPLIED WARRANTY OF MERCHANTABILITY OR FITNESS, AND MIMAKI NEITHER ASSUMES NOR AUTHORIZES DEALER TO ASSUME FOR IT ANY OTHER OBLIGATION OR LIABILITY OR MAKE ANY OTHER WARRANTY OR MAKE ANY OTHER WARRANTY IN CONNECTION WITH ANY PRODUCT WITHOUT MIMAKI'S PRIOR WRITTEN CONSENT.

IN NO EVENT SHALL MIMAKI BE LIABLE FOR SPECIAL, INCIDENTAL OR CONSEQUENTIAL DAMAGES OR FOR LOSS OF PROFITS OF DEALER OR CUSTOMERS OF ANY PRODUCT.

## Requests

- This Operation manual has been carefully prepared for your easy understanding.  
However, please do not hesitate to contact a distributor in your district or our office if you have any inquiry.
- Description contained in this Operation manual are subject to change without notice for improvement.

## FCC Statement (USA)

This equipment has been tested and found to comply with the limits for a Class A digital device, pursuant to Part 15 of the FCC Rules. These limits are designed to provide reasonable protection against harmful interference when the equipment is operated in a commercial environment. This equipment generates, uses and can radiate radio frequency energy and, if not installed and used in accordance with the Operation manual, may cause harmful interference to radio communications.

Operation of this equipment in a residential area is likely to cause harmful interference in which case the user will be required to correct the interference at his own expense.

In the case where MIMAKI-recommended cable is not used for connection of this device, limits provided by FCC rules can be exceeded.

To prevent this, use of MIMAKI-recommended cable is essential for the connection of this printer.

## Interference to televisions and radios

The product described in this manual generates high frequency when operating.

The product can interfere with radios and televisions if set up or commissioned under improper conditions.

The product is not guaranteed against any damage to specific-purpose radio and televisions.

The product's interference with your radio or television will be checked by turning on/off the power switch of the product.

In the event that the product is the cause of interference, try to eliminate it by taking one of the following corrective measures or taking some of them in combination.

- Change the orientation of the antenna of the television set or radio to find a position without reception difficulty.
- Separate the television set or radio from this product.
- Plug the power cord of this product into an outlet which is isolated from power circuits connected to the television set or radio.

## About usable ink

Usable ink for this machine is SU100 ink (four-color).

For information about the ink cartridges to use, see "Setting orders of ink cartridges" (P.6-4).

- JV400 SUV Series : SU100 (4 color: Cyan, Magenta, Yellow, Black)
- SUJV-160 : SU200 (4 color: Cyan, Magenta, Yellow, Black + Clear)

## About usable media

Only roll media is usable for this machine.

It does not support leaf media.

## On This Operation manual

- This Operation manual is describing the operations and maintenance of "Color inkjet printer JV400 SUV Series and SUJV-160." (called as this machine hereafter)
- Read this Operation manual carefully and understand them thoroughly to use.
- It is also necessary to keep this Operation manual on hand.
- This Operation manual has been carefully prepared for your easy understanding, however, please do not hesitate to contact a distributor in your district or our office if you have any inquiry.
- Descriptions contained in this Operation manual are subject to change without any notice for improvement.
- In the case when this Operation manual should be illegible due to destruction or lost by fire or breakage, purchase another copy of the Operation manual from our office.
- You can also download the latest manual from our website.











Reproduction of this manual is strictly prohibited.  
All Rights Reserved. Copyright  
© 2015 MIMAKI ENGINEERING Co., Ltd.

# Safety Precautions



## Symbols

Symbols are used in this Operation Manual for safe operation and for prevention of damage to the machine. The indicated sign is different depending on the content of caution. Symbols and their meanings are given below. Please follow these instructions as you read this manual.

### Examples of symbols

Meaning	
	Failure to observe the instructions given with this symbol can result in death or serious injuries to personnel. Be sure to read it carefully and use it properly.
	Failure to observe the instructions given with this symbol can result in injuries to personnel or damage to property.
	Important notes in use of this machine are given with this symbol. Understand the notes thoroughly to operate the machine properly.
	Useful information is given with this symbol. Refer to the information to operate the machine properly.
	Indicates the reference page for related contents.
	The symbol "  " indicates that the instructions must be observed as strictly as the CAUTION instructions (including DANGER and WARNING instructions). A sign representing a precaution (the sign shown at left warns of hazardous voltage) is shown in the triangle.
	The symbol "  " indicates that the action shown is prohibited. A sign representing a prohibited action (the sign shown at left prohibits disassembly) is shown in or around the circle.
	The symbol "  " indicates that the action shown must be taken without fail or the instructions must be observed without fail. A sign representing a particular instruction (the sign shown at left instructs to unplug the cable from the wall outlet) is shown in the circle.

### Warning for Use

 <b>WARNING</b>	
	<ul style="list-style-type: none"> <li>• Do not use the machine in a poorly ventilated room or a closed room.</li> <li>• Use the attached power cable.</li> <li>• Take care not to damage, break or work upon the power cable. If a heavy material is placed on the power cable, or if it is heated or pulled, the power cable can break, thus resulting in fire or electric shocks.</li> <li>• Avoid locating the machine in a damp environment. Do not splash water onto the machine. Use in such an environment can give rise to fire, electric shocks or breakdown of the machine.</li> <li>• Use of the machine under an abnormal condition where it produces smoke or strange smell can result in fire or electric shocks. If such an abnormality is found, be sure to turn off the power switch immediately and unplug the cable from the wall outlet. Check first that the machine no longer produces smoke, and then contact your distributor or a sales office of MIMAKI for repair.</li> <li>• Never repair your machine by yourself since it is very dangerous for you to do so.</li> <li>• Never disassemble or remodel the main unit of the machine or the ink cartridge. Disassembly or remodeling can result in an electric shock or breakdown of the machine.</li> <li>• Take care that no dust or dirt sticks to platen heaters. Dust and dirt sticking heaters can cause fire.</li> <li>• Hazardous moving parts keep fingers and other body parts away.</li> </ul>



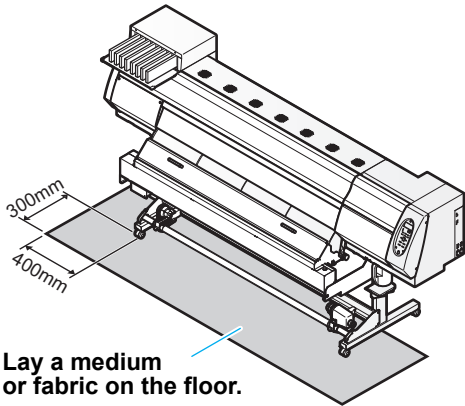

## CAUTION

<p><b>Power supply</b></p> <ul style="list-style-type: none"> <li>• Leave the breaker turned ON.</li> <li>• Do not turn off the main power switch on the right side of this machine.</li> </ul>	<p><b>Handling of the power cable</b></p> <ul style="list-style-type: none"> <li>• Use a power cable attached to this unit.</li> <li>• Take care not to damage, break or work on the power cable. If a heavy matter is placed on the power cable, heated or drawn, the power cable can break to cause fire or electric shocks.</li> <li>• Connect to a socket-outlet with determinate polarity.</li> <li>• for PLUGGABLE EQUIPMENT, the socket-outlet shall be installed near the equipment and shall be easily accessible.</li> </ul>
<p><b>Heater</b></p> <ul style="list-style-type: none"> <li>• Do not spill liquid on the platen as this may cause failure of the heater or firing.</li> <li>• Do not touch platen heaters with bare hand while it is hot; otherwise, you can get burned.</li> <li>• When the machine is to be moved, wait until the heater temperature drops adequately. As a criterion, wait at least 30 minutes after you turn off the power to the heater. Moving the machine must be limited to on the same floor where there is no steps. When the machine is to be moved to any place other than on the same step-free floor, contact your distributor or a sales office of MIMAKI.</li> </ul>	<p><b>Handling of ink</b></p> <ul style="list-style-type: none"> <li>• If you get ink in your eyes, immediately wash your eyes with a lot of clean water for at least 15 minutes. In doing so, also wash eyes to rinse ink away completely. Then, consult a doctor as soon as possible.</li> <li>• If anyone drinks ink by mistake, keep him or her quiet and see a doctor immediately. Do not allow him or her to swallow the vomit. The contact the emergency number written in MSDS.</li> <li>• If you inhale a lot of vapor and feel bad, immediately move to a location of fresh air and then keep yourself warm and quiet. Then, consult a doctor as soon as possible.</li> </ul>
<p><b>UV light</b></p> <ul style="list-style-type: none"> <li>• There is some leaking of ultraviolet radiation around the UV irradiation device. UV light applied to your skin might cause inflammation and/or skin cancer. Though weak UV light might cause no inflammation, repeated exposure to it may lead to chronic disorders. Avoid applying UV light to your skin and eyes.</li> <li>• Impairment of eyes caused by UV light may be Acute disorders. Pain in eyes, tearing, etc. Chronic disorders Cataract, etc. When using this device, take protective measures such as gloves, long-sleeve cloth, light-resistant mask, attached light-resistant glasses, etc.</li> <li>• Surface of the floor becomes discolored due to UV leaks from the printer. Cover the floor with cloth or medium for shielding the light.</li> </ul> <p>Desirable size of cloth or medium:                  JV400-130SUV: 2500mm X 600mm                  JV400-160SUV, SUJV-160: 2800mm X 600mm</p> <div style="text-align: right;">  <p><b>Lay a medium or fabric on the floor.</b></p> </div>	
<p><b>Note on maintenance</b></p> <ul style="list-style-type: none"> <li>• When cleaning the ink-station or the heads, make sure to wear the attached goggles and gloves.</li> <li>• Do not leave the machine for a long time with the cover opened. Ink may be cured due to outside light, and it may cause discharge defect.</li> </ul>	

## CAUTIONS and NOTES

 <b>Warning</b>	
<b>Handling of ink cartridges</b> <ul style="list-style-type: none"> <li>• Use the JV400-SUV genuine ink or the SUJV-160 genuine ink. Remember that the user shall be filled for a repair to correct any damage resulting from the use of ink other than the exclusive type.</li> <li>• The machine does not operate with any ink other than the JV400-SUV genuine ink and the SUJV-160 genuine ink.</li> <li>• Do not use the JV400-SUV genuine ink and the SUJV-160 genuine ink with other printers, as doing so may cause damage to such machines.</li> <li>• Never refill the ink cartridge with ink. Refilled ink cartridge can cause a trouble. Remember that MIMAKI assumes no responsibility for any damage caused by the use of the ink cartridge replenished with ink.</li> <li>• If the ink cartridge is moved from a cold place to a warm place, leave it in the room temperature for three hours or more before using it.</li> <li>• Open the ink cartridge just before installing it in the machine. If it is opened and left for an extended period of time, normal printing performance of the machine may not be ensured.</li> <li>• Make sure to store ink cartridges in a cool and dark place.</li> <li>• Store ink cartridges and waste ink tank in a place that is out of the reach of children.</li> <li>• Be sure to thoroughly consume the ink in the ink cartridge, once it is opened, within three months. If an extended period of time has passed away after opening the cartridge tank, printing quality would be poor.</li> <li>• Neither pound the ink cartridge nor shake it violently, as doing so can cause leakage of ink.</li> <li>• Do not touch or stain the contacts of the ink cartridge, as doing so may cause damage to the print circuit board.</li> </ul> <p>Waste ink is equivalent to waste oil of industrial waste. Request an industrial waste disposal company for disposal of waste ink.</p>	<b>Front cover and lever</b> <ul style="list-style-type: none"> <li>• Never open the front cover or raise the lever during printing. Opening the cover or raising the lever will abort printing.</li> </ul>
	<b>Handling of media</b> <ul style="list-style-type: none"> <li>• Use media recommended by MIMAKI to ensure reliable, high-quality printing.</li> <li>• Set the heater temperature to meet the characteristics of the media.                             <p>Set the temperature of the Pre-heater, Print heater and Post-heater according to the type and characteristics of the media used. Automatic temperature setting can be made on the operation panel by setting the profile on the dedicated RIP. For setting on the RIP, refer to the instruction manual for your RIP.</p> </li> <li>• Pay attention to the expansion and contraction of the media.                             <p>Do not use media immediately after unpacking. The media can be affected by the room temperature and humidity, and thus it may expand and contract. The media have to be left in the atmosphere in which they are to be used for 30 minutes or more after unpacked.</p> </li> <li>• Do not use curled media.                             <p>The use of curled media can not only cause a media jam but also affect print quality. Straighten the sheet of media, if significantly curled, before using it for printing. If a regular-sized coated sheet of media is rolled and stored, the coated side has to face outside.</p> </li> <li>• Do not leave the media with the heater ON for a long time.</li> </ul>
	<b>Protection of media from dust</b> <ul style="list-style-type: none"> <li>• Store media in a bag. Wiping off dust accumulated on media will adversely affect the media due to static electricity.</li> <li>• When leaving the workshop after the working hours, do not leave any media on the roll hanger. If any media is left on the roll hanger, it can get dusty.</li> </ul>



## Warning

### Notes on UV LED

- Do not use the UV irradiation device in an ambience with a possibility of catching fire (gasoline, combustible gas spray, thinner, lacquer, powder dust, etc.). In addition, do not put paper or cloth near or on the UV irradiation device, or it may cause fire. or it may cause electrical shock.
- The UV lamp is made of glass and should not be dropped, hit against anything, given excessive force or scratched, or it may cause damage to the UV lamp.
- Never look at the UV lamp being lit with your naked eyes, or it may cause pain in your eyes or visual impairment. Be sure to wear safety glasses.
- Do not apply ultraviolet (UV) light directly to your skin, or it may cause irritation on your skin.
- The UV lamp may be damaged in rare cases. If it is damaged, contact a distributor in your district or our office to call for service.
- Do not touch the lamp on or right after the lamp off with bare hands to avoid from burn injury.
- The UV lamp performance and service life are significantly affected by the UV irradiation and UV power supply units used. Never use those UV devices other than those recommended by Mimaki. We would take no responsibility for any troubles caused through the use of a UV devices not recommended by Mimaki.
- Touching hot parts such as the UV irradiation device with combustible materials may cause firing and/or smoking. Leaving combustible materials under the UV irradiation device for a couple minutes may also cause firing and/or smoking.

### Notes on maintenance

- It is strongly recommended to use the machine in a room that is not dusty.
- Keep the front cover closed even when the machine is not printing. If not, dust can accumulate on the nozzles in the heads.
- Dust in the heads can also cause drops of ink to fall suddenly down on the media during printing. In such a case, be sure to clean up the heads. (P.4-19 "Cleaning the Head and the Area around It (every day)")
- When cleaning the ink-station or the heads, make sure to wear the attached gloves.
- Perform wiping (removal of dust and paper powder) of the capping station and wiper frequently.



### Periodic replacement parts

- Some parts of this machine must be replaced with a new one periodically by service personnel. Be sure to make a contract with your distributor or dealer for After sale service to ensure a long life of your machine.

### Disposition of this machine

- When discarding this machine, request the treatment of it for an industrial waste disposal contractor.
- Treat it properly in compliance with regulation in the local area.

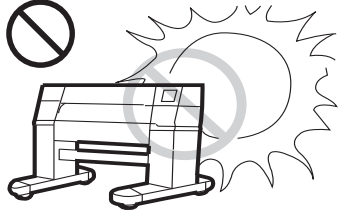
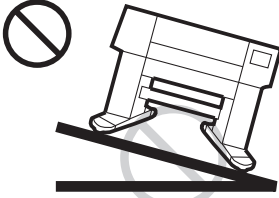
## Cautions on Installation

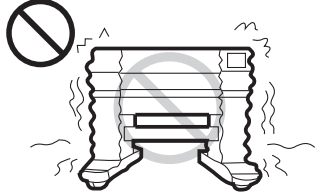
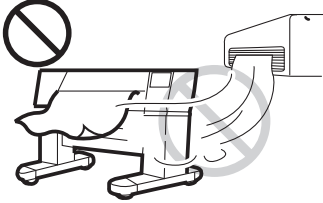
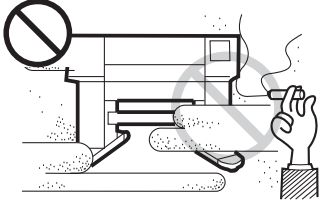
 <b>CAUTION</b>		
<b>A place exposed to direct sunlight</b>	<b>On an inclined surface</b>	<b>A place where temperature or humidity varies significantly</b>
		 <ul style="list-style-type: none"> <li>• Use the machine under the following environmental conditions:</li> <li>• Operating environment: 20 to 30 °C (68 to 86 °F) 35 to 65 % (Rh)</li> </ul>
<b>A place that vibrates</b>	<b>A place exposed to direct air flow from an air conditioner or the like.</b>	<b>Around a place where fire is used</b>
		

## Safety interlock

This machine is equipped with interlocks to terminate the operation for your safety when the cover opens during printing etc. (red circle parts in the figure below).

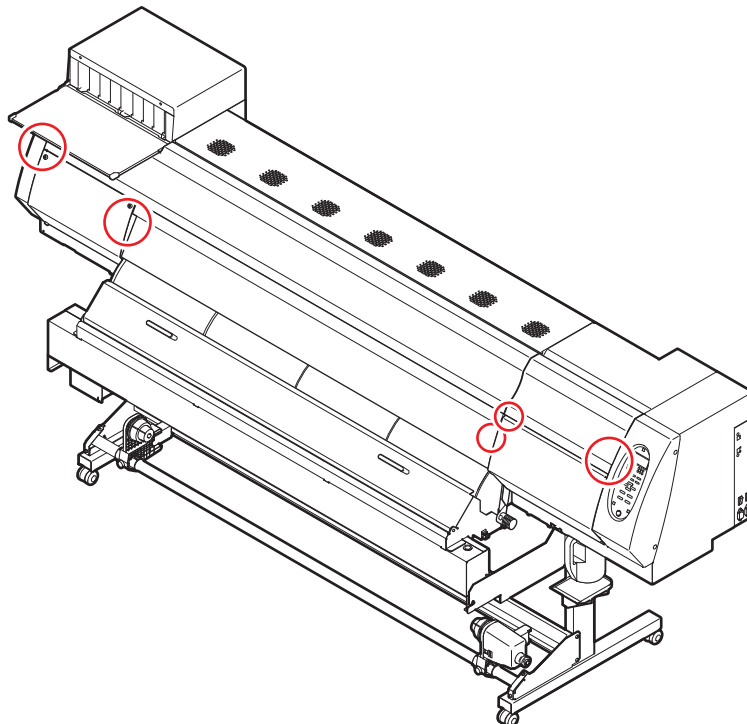

# Chapter 1

## Before Use



### This chapter

describes the items required to understand before use, such as the name of each part of the machine or the installation procedures.

Moving This Machine .....	1-2	Connecting USB2.0 Interface Cable .....	1-10
Where to Install This Machine .....	1-2	Connecting the power cable .....	1-11
Working Environmental Temperature .....	1-2	Inserting ink cartridges .....	1-12
Moving This Machine .....	1-3	Caution in handling of ink cartridges .....	1-12
Names of Parts and Functions .....	1-4	Insert an ink cartridges .....	1-13
Front Side of the Machine .....	1-4	Changing an ink cartridge .....	1-14
Rear Side and Right Side of the Machine ...	1-5	For Ink cartridge lamps .....	1-14
Operation Panel .....	1-6	Restrictions concerning the product .....	1-14
Heater .....	1-7	About cartridge ink end and ink near end ..	1-14
Media sensor .....	1-7	How to assemble ink cartridge .....	1-15
Carriage .....	1-8	Media .....	1-17
Cutter blade and slot for cutting .....	1-8	Usable sizes of media .....	1-17
Capping station .....	1-9	Caution in handling of medias .....	1-17
Pinch rollers and Feed rollers .....	1-9	About antistatic sheet .....	1-19
Connecting Cables .....	1-10		

# Moving This Machine

## Where to Install This Machine

Secure a suitable installation space before assembling this machine.

The place of installation must have enough space for not only this machine itself, but also for the printing operation.

Model	Width	Depth	Height	Gross weight
JV400-130SUV	2634mm	861mm	1435mm	212kg
JV400-160SUV SUJV-160	2879mm	861mm	1435mm	250kg

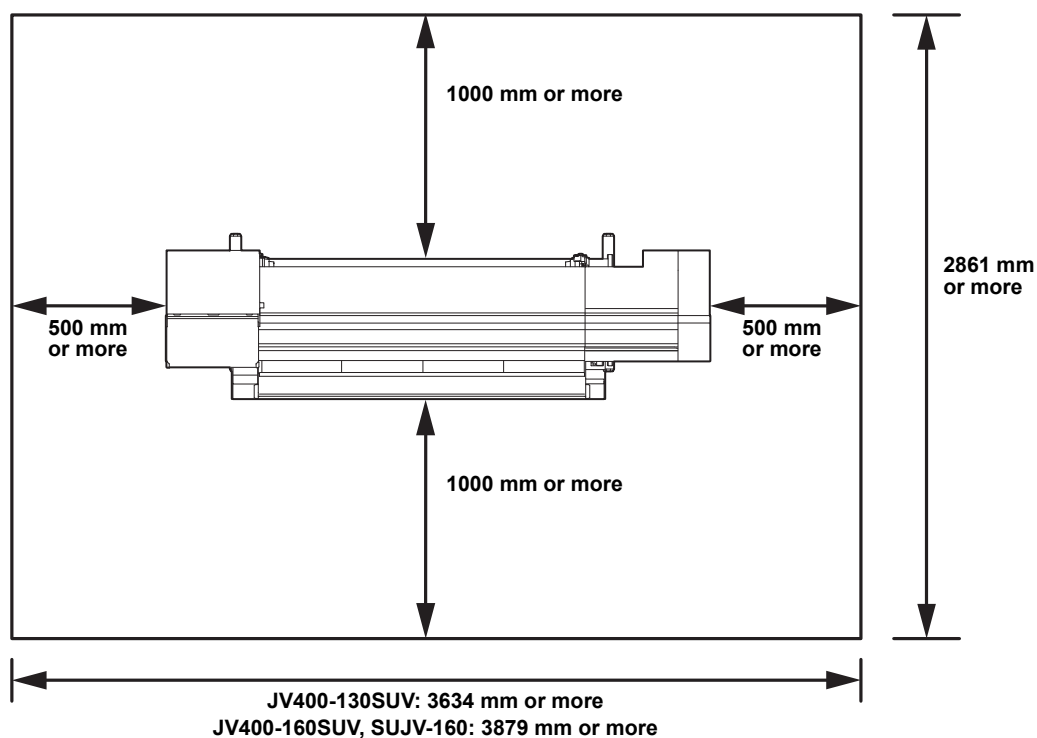

## Working Environmental Temperature

Use this machine in an environment of 20 to 30°C to ensure reliable printing.

The heater temperature may not reach the set value, depending on the ambient temperature.

## Moving This Machine

Move this machine according to the following steps when this machine needs to be moved on the same step-free floor.



- When the machine is moved to any place other than on the same step-free floor, contact your distributor or our service office.  
If you move it by yourself, failure or damage may occur.  
Be sure to request your distributor or our service office to move this machine.



- When moving this machine, take care that it does not receive a significant impact.
- Be sure to lock the caster after moving of this machine.

**1**

**Release the lock of caster.**

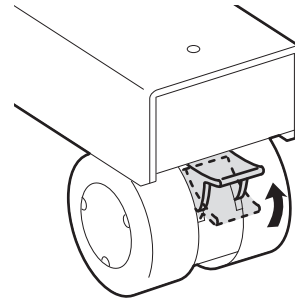

**2**

**Move this machine as shown in the figure.**

- For safety, be sure to operate it with 4 people or more.
- Do not push the cover to move this machine since the cover may be broken.

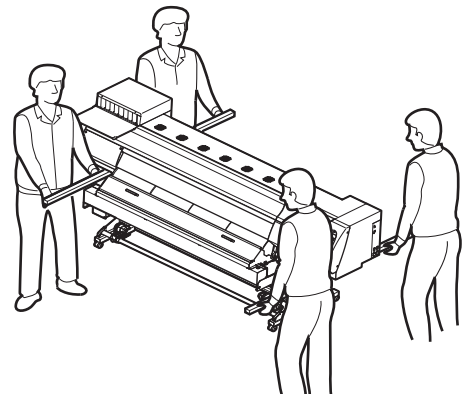

**3**

**Lock the caster.**

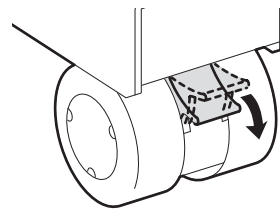

**1**

**Before Use**

# Names of Parts and Functions

## Front Side of the Machine

### Left maintenance cover

Open the cover in maintenance.  
Even when the power switch is off, keep all covers closed.

### Ink cartridges

Each cartridge contains an ink of a particular color.

### Cartridge protection cover

This prevents an injury or breakage of the machine due to a protrusion of the 600 cc cartridge.  
(It is located under the ink cartridge.)

### Front cover

Open the cover in setting of medias, taking of measures against jamming of medias or in maintenance inside the station.  
Even when the power switch is off, keep this cover and the other covers closed.

### UV lamp unit

The lamp unit to cure printed ink.

### Shading cover

This cover blocks the UV light from the UV lamp unit.

### Right maintenance cover

Open this cover during maintenance.

### Operation panel

This panel has the operation keys required for operating the machine and the LCDs for displaying setting items, etc.

### Power switch<sup>\*1</sup>

Turns on/off the power to the machine.

### Take-up device

Take up the output drawn with a roll medium automatically.

### Waste ink tank

Waste ink gathers in this tank.

### Clamp lever (front)

Moves the pinch rollers up and down to hold or release the media.

### Stand

Supports the main body of the machine. It is provided with casters that are used to move this machine.

### Platen

The printed media is sent out, sliding on the platen. Three heaters are installed inside the platen.

### Print heater/ Post-heater

Fixes and dries the ink on the currently produced print. (Located inside the platen)

### Electrostatic sheet

Prevents the media from sticking to the platen due to static.

\*1: The power switch under the operation panel lights in green when the power is turned on. The ink clogging prevention function is periodically operated even when the power switch is OFF if the main power switch keeps being ON. (Auto maintenance function)  P.1-5



# Rear Side and Right Side of the Machine

1

Before Use

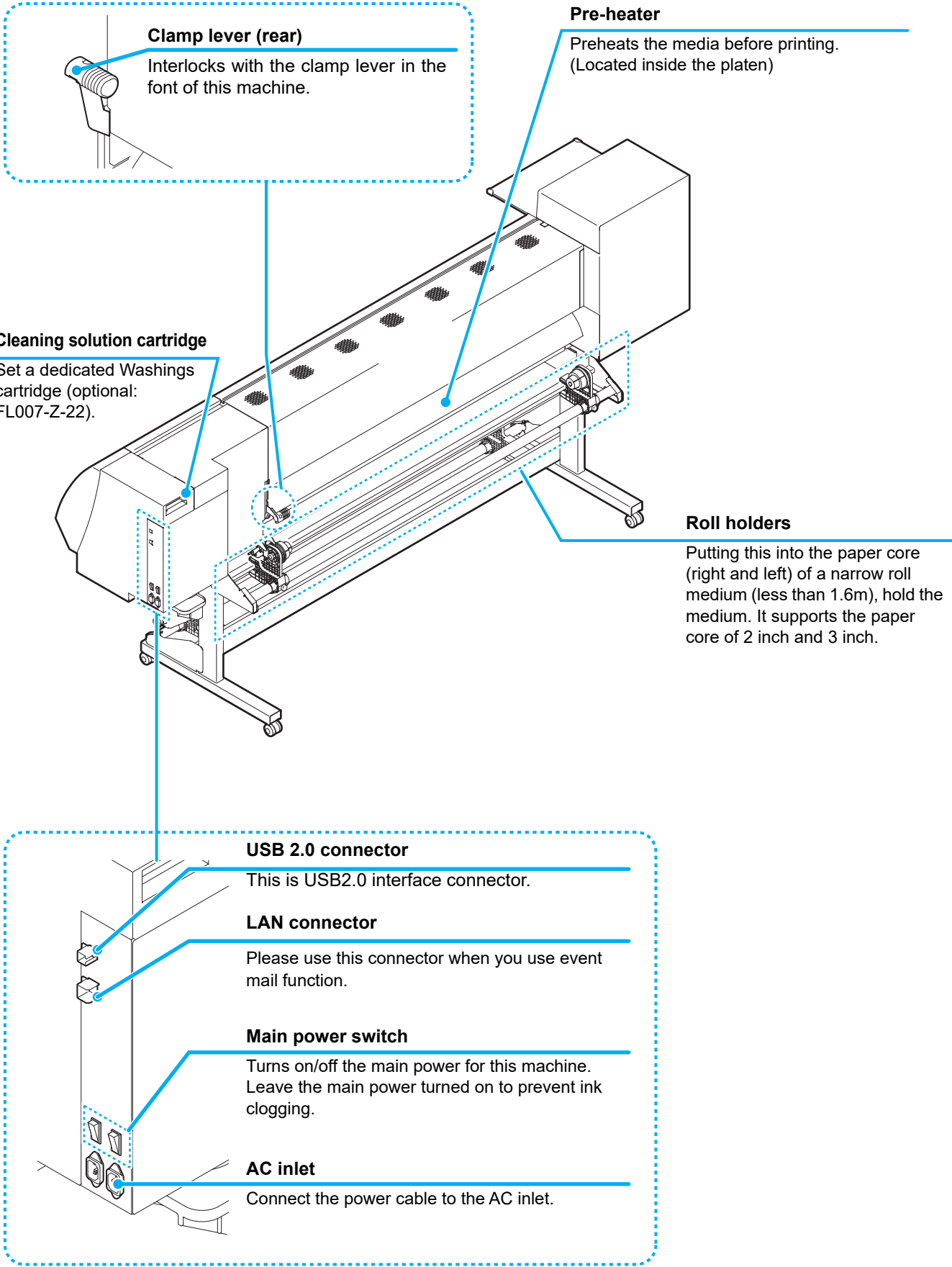

# Operation Panel

Use the operation panel to make settings for printing or operate this machine.

## Display

Displays the status of the machine, set items and errors.

## ACTIVE lamp

It lights when the power supply is turned on.

### ADJUST key

Performs the adjusting function such as "Drop.POScorrect" and "Feed COMP."

### MAINT. key

Performs the maintenance function such as station maintenance.

### DATA CLEAR key

Deletes the data that have been received.

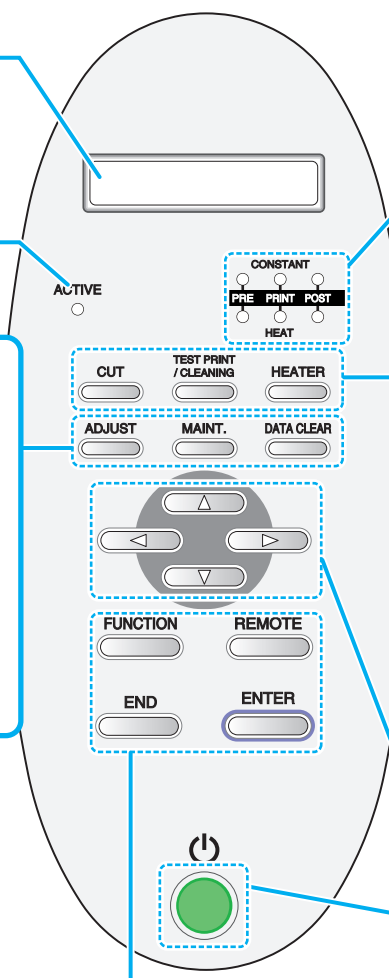

## CONSTANT lamp

Lights in green when the heater temperature reaches the set temperature.

## HEAT lamp

Lights in orange during heating up of the heater.

## CUT key

Use this key on cutting .

## TEST PRINT/CLEANING key

Draws test patterns to check if there are any drawing failures such as ink clogging. Or executes Head cleaning at ink clogging.

## HEATER key

Use this key to set the temperatures of the Pre-heater, Print heater and Post-heater or check the current temperature of the platen.

## JOG key

Use these keys to shift the carriage or the media in [LOCAL]. Also use them to select an item of printing conditions.

## Power switch

Turns on/off the power to the machine.

### FUNCTION key

Use this key to display function setting menu.

### END key

Cancels the last input value or returns the setting menu to the immediate higher level of the hierarchy.

### REMOTE key

Use this key to switch between [REMOTE] and [LOCAL].

### ENTER key

Registers the last input value as the setting value or goes to the immediate lower level of the hierarchy.

## Heater

Pre-heater/Print heater/Post-heater are equipped on the platen.

The Pre-heater is used for pre-heating of the media prior to printing to prevent rapid changes in temperature. The Print-heater improves the image quality in printing. The Post-heater dries ink after printing.



- While the heater is on, the platen is very hot. When the front cover is to be opened or media is to be replaced, lower the heater temperatures and wait until the platen temperature drops; otherwise, you can get burned.
- When the media is to be replaced with a thin one, lower the heater temperatures and wait until the platen temperature drops adequately. Setting a thin sheet of media while the platen is hot may cause the media to stick to the platen or cause wrinkling or curling of the media.

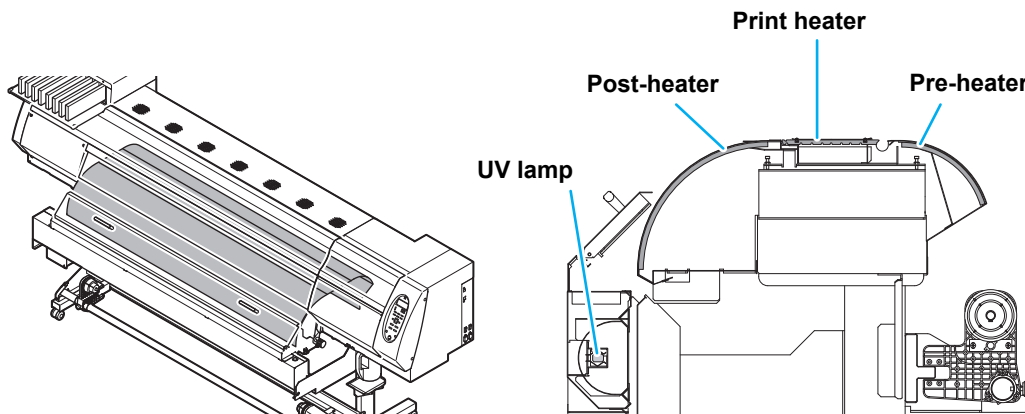

## Media sensor

The media sensor detects the presence of the media and the media length.

This machine has a media sensors on the platen (in the rear).

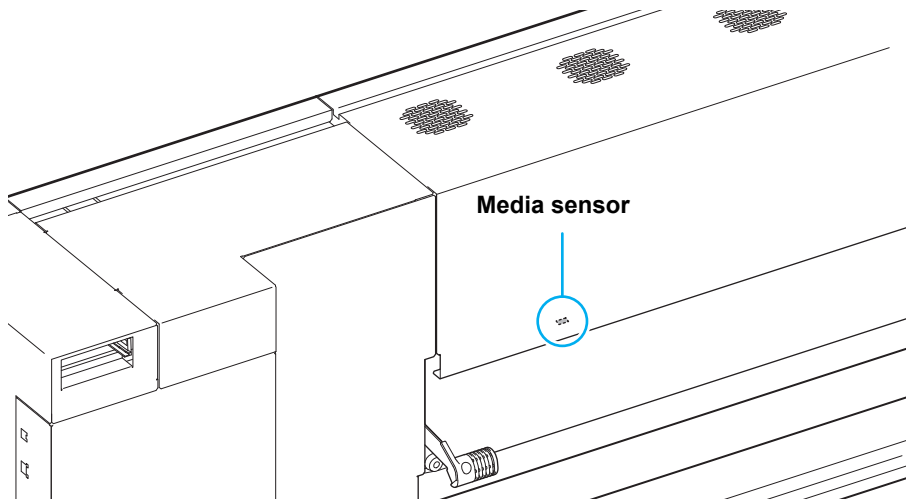

- When setting a medium, be sure to cover the medium sensors located on the rear of the platen. The media cannot be detected unless it is placed over the sensor.

## Carriage

The carriage is provided with the heads for printing, the cutter unit for cutting off the sheet of media, etc.  
A lever is also provided to adjust the height of Head in 3 stages according to the thickness of media. (☞ P.2-5)

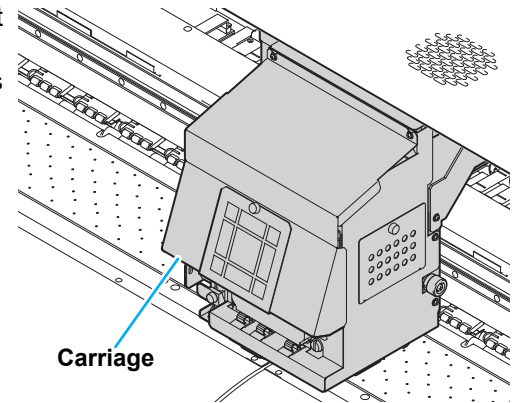

## Cutter blade and slot for cutting

The carriage is provided with a cutter unit for cutting off the media that has been printed on.  
The cutter cuts off the sheet of media along the slot for cutting on the platen.  
The cutter blade is consumables. If it gets dull, replace it with new one. (☞ P.4-39)

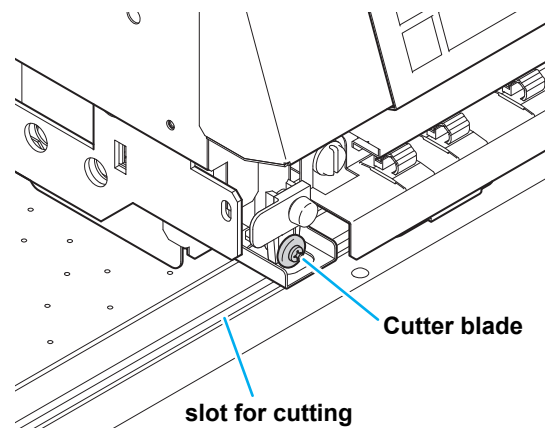
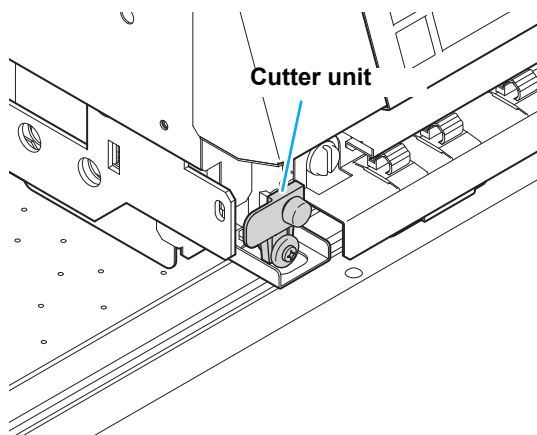

## Capping station



- Be sure to wear the attached safety glasses in cleaning within the capping station to protect your eyes against ink. Otherwise, you may get ink in your eyes.

The capping station consists of the ink caps, the wiper for cleaning the heads, etc.

The ink caps prevent the nozzles in the heads from drying up.

The wiper cleans the nozzles in the heads.

The wiper is consumable. If the wiper is deformed or the media is stained, replace the wiper with a new one.

(☞ P.4-34)

- The cap shape of SUJV-160 is different.

JV400-SUV130/160 の場合

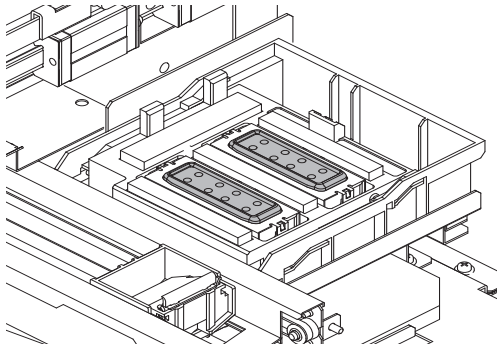

SUV-160 の場合

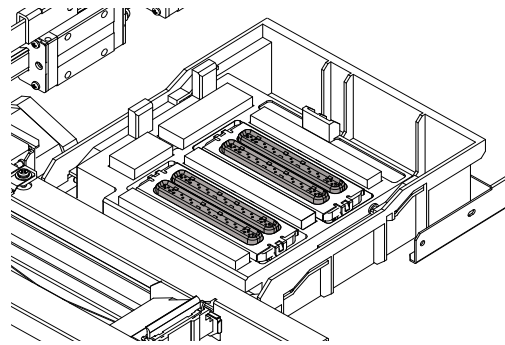

## Pinch rollers and Feed rollers

**Important!**

- Keep the pinch rollers lifted up when this machine is not in use. If the pinch rollers are left lowered for an extended period of time, they can be deformed and fail to securely retain the media.

This machine retains the media with the pinch rollers and feed rollers. During printing operation, the feed rollers feed the media forward.

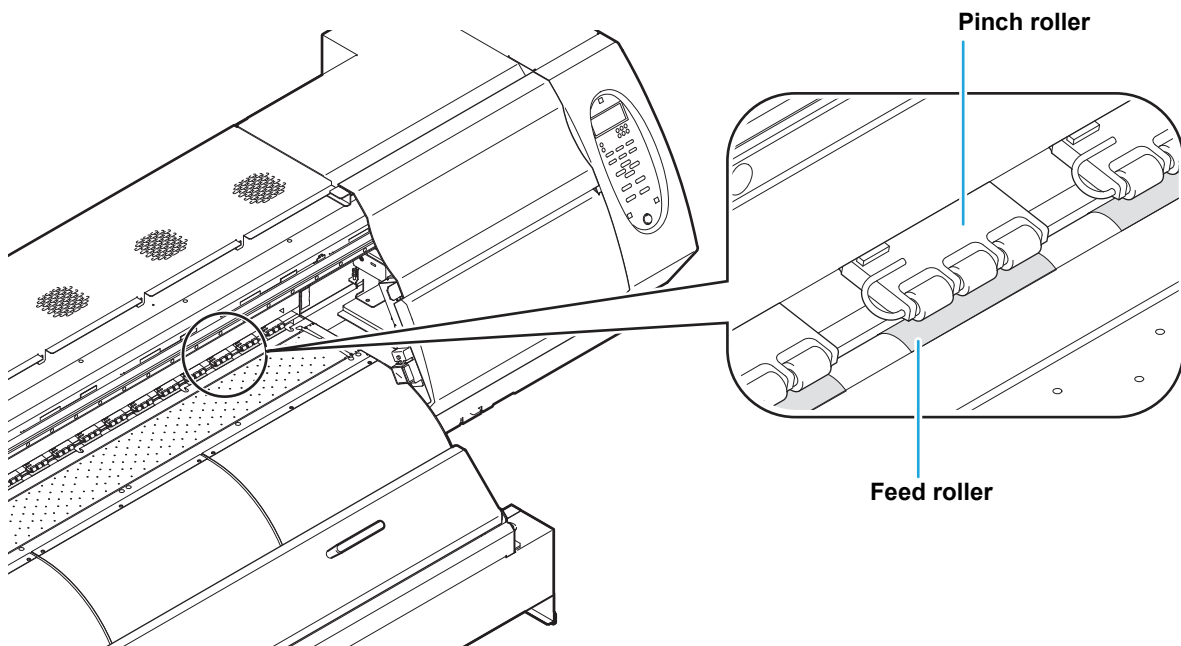

# Connecting Cables

## Connecting USB2.0 Interface Cable

Connect the PC and this machine with the USB2.0 interface cable.



- Your RIP must be compatible with USB 2.0.
- Contact a RIP maker near your location or our office when the USB2.0 interface is not attached to the PC.

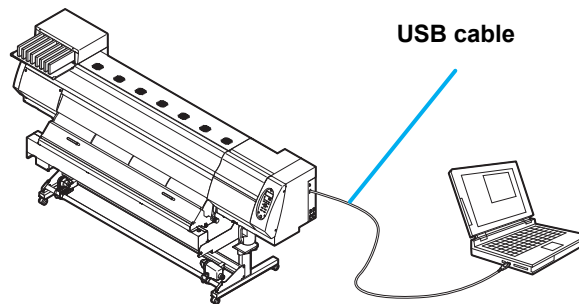

### Notes on USB 2.0 Interface



- Your RIP must be compatible with USB 2.0.

#### ● When two or more JV400, SUJV-160 machines are connected to one personal computer

When two or more JV400, SUJV-160 machines are connected to one personal computer, the personal computer may not recognize all the JV400, SUJV-160 machines normally.

Reconnect the unrecognized JV400, SUJV-160 machine to another USB port, if available, and check to see if it is recognized. If the JV400, SUJV-160 machine is not recognized by the newly connected USB port, use USB 2.0 repeater cables available on the market.

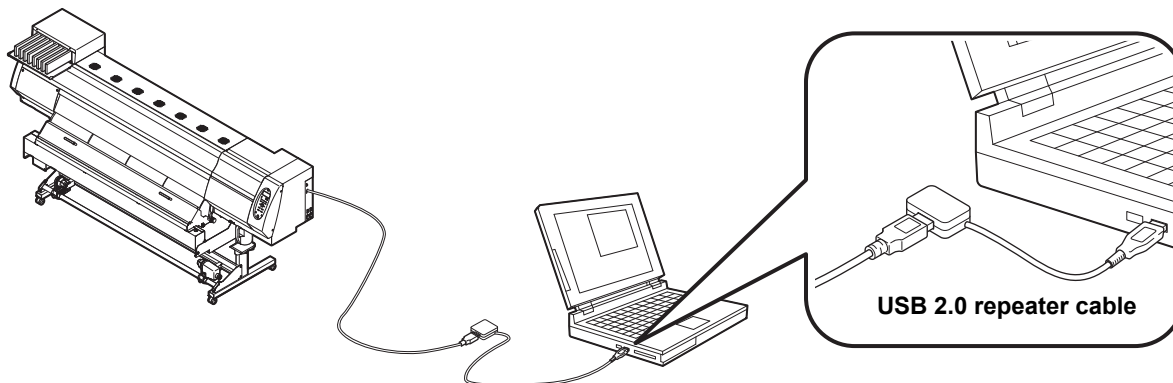

#### ● Notes on peripheral devices in USB high speed mode

When a peripheral device (USB memory or USB HDD) to be operated in USB high speed mode is connected to the same personal computer that a JV400, SUJV-160 machine is connected to, the USB device may not be recognized.

When JV400, SUJV-160 is connected to the personal computer to which an external HDD is connected via USB, the speed of data output to JV400, SUJV-160 may drop. That can cause the head unit to stop temporarily at the right or left end during printing.

## ● Removing USB memory

If a USB memory module is inserted in the personal computer to which a JV400, SUJV-160 machine is connected, click "Stop" in the "Safely Remove Hardware" window by following the instructions given there first and then remove the module.

Leaving a USB memory module inserted can cause [ERROR 201 COMMAND ERROR].

Copy the data onto the hard disk before outputting it for printing.

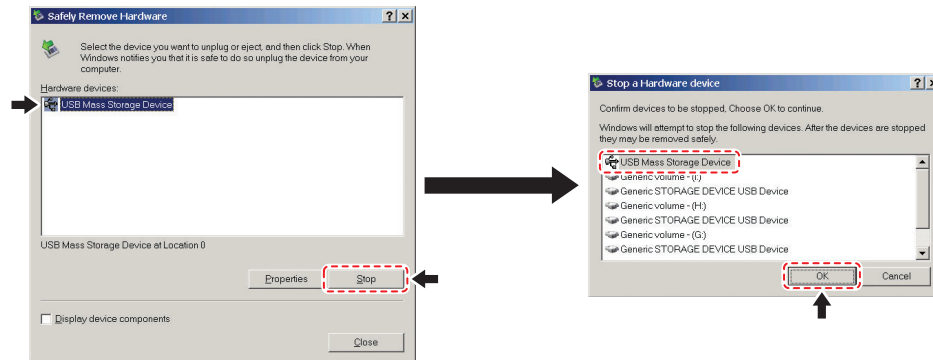

1

Before Use

## Connecting the power cable

**1** Insert the power cable into an inlet of the machine.

**2** Secure a cable band.

- Secure the cable with the cable band attached to this machine.

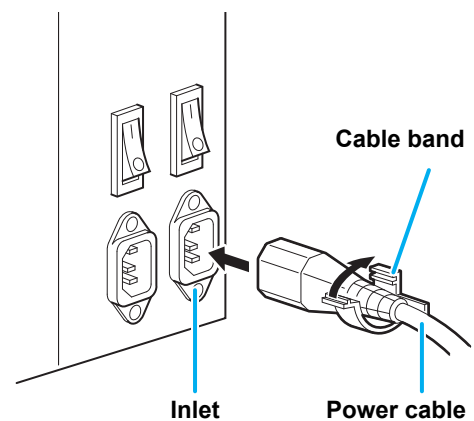

**3** Insert the power plug into a plug socket.

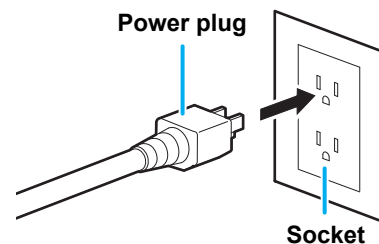

Warning

- Do not use any power cables other than the attached power cable.



Important!

- Be sure to connect the power cable to the outlet near this machine, and make sure that the power cable can be easily removed.
- Connect the power cable to the grounded outlet. Otherwise, it may result in fire or an electric shock.

# Inserting ink cartridges

## Caution in handling of ink cartridges



- If you get ink in your eyes, immediately wash your eyes with a lot of clean running water for at least 15 minutes. In doing so, also wash the eyes to rinse ink away completely. Then, consult a doctor as soon as possible.
- Use genuine ink cartridges for this machine. This machine functions by recognizing the genuine ink cartridges. In case of troubles caused by modified ink cartridges or the like, it shall be out of the warranty even within the warranty period.
- If the ink cartridge is moved from a cold place to a warm place, leave it in the room temperature for three hours or more before using it.
- Make sure to store ink cartridges in a cool and dark place.
- Store ink cartridges and waste ink tank in a place that is out of the reach of children.
- Request an industrial waste processor for processing of empty ink cartridges.



- Do not shake ink cartridges violently. This may result in ink leakage from the ink cartridges.
- Never refill the ink cartridges with ink. This may result in troubles.  
MIMAKI will not bear any responsibility for any damage caused by the use of the ink cartridges refilled with ink.
- Do not touch or stain the contacts of the ink cartridge. This may cause damages on printed circuit boards.

## Caution in installing products with 600 ml ink



- Be sure to refer to the instruction manual for “Caution for handling 600 ml packs (D202845)” attached with machine accessory box. Keep this note together with other manuals.



# Insert an ink cartridges

## 1 Shake the ink cartridge as shown.

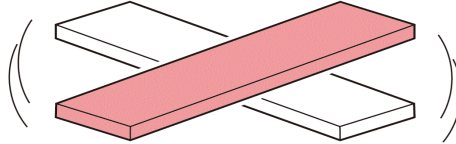

- For solvent UV ink, shake the ink cartridge about once a month.

### • When using a 600ml cartridge

When using a used ink pack, to prevent ink from leaking when you shake the cartridge, wear gloves and firmly cover the A part of the upper surface of the cartridge and the B part of the bottom surface of the cartridge with paper towels. Then, shake it more than twenty times right and left so that ink flows inside the cartridge.

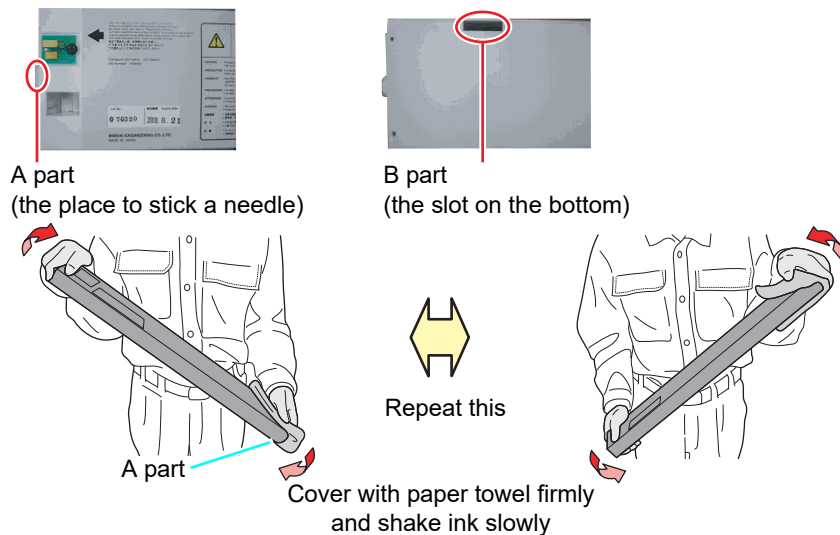

- If you shake it too strong, the pack inside may be damaged and it may cause ink leakage. Therefore, perform this carefully.
- If the remaining amount of ink is less, ink in the cartridge cannot be beaten enough. Tilt the cartridge until it becomes vertical.

## 2 Insert the ink cartridge.

- Insert the ink cartridge lengthwise with the surface having ink IC chips pointing to the left side.
- For the setting orders of the ink cartridges, refer to P.6-4.

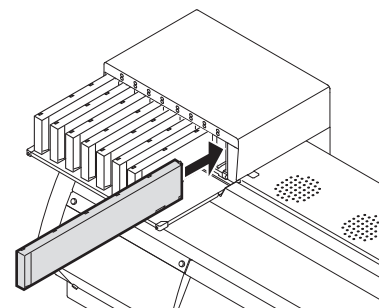

## Changing an ink cartridge

Perform as follows when [INK END] or [INK NEAR END] is displayed on the display.

### ● When [INK END] is displayed

- (1) Pull out an ink cartridge to be replaced.
- (2) Insert a new ink cartridge, paying attention to the direction of ink IC chip.

### ● When [INK NEAR END] is displayed

There is a little of ink left. It is recommended to replace the ink cartridge soon since ink may become empty in printing while printing is continuously enabled.

When you press the **ENTER** key in LOCAL, you can check the cartridge to be replaced in the local guidance. (☞ P.3-41)



- When you changed the ink pack, be sure to change the ink IC chip, too.

## For Ink cartridge lamps

The condition of the ink cartridges set in the machine is confirmable with lamps located over the ink cartridges.

Ink cartridge lamps

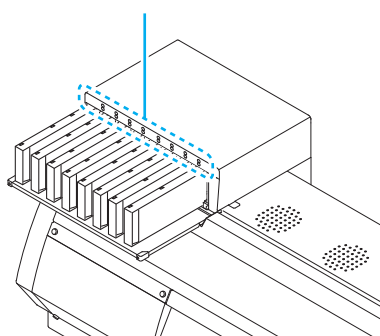

Condition of Lamp		Description
Upper row Red lamp	OFF	No error
	Blinking	There is less ink in the ink cartridge (Near End), or ink has expired. It will become unusable soon.
	ON	There is no ink in the ink cartridge, or the ink cartridge cannot be used due to other ink error. (☞ P.5-5)
	Quick blinking	As ink has expired, the ink cartridge cannot be used.
Lower row Green lamp	OFF	No error
	ON	Indicates that ink is supplied. When you use four-color ink set, this machine first supplies ink from the ink cartridge whose ink expires soon.

## Restrictions concerning the product

The ink expiration date is indicated on the Ink cartridge. Expired ink may cause printing defects or alter the color tone. Printing is possible even if the ink has passed its expiration date. Nevertheless, we recommend replacing with new ink or use up as quickly as possible.

Example: The expiration date is April.

May: Replace with new ink or use up as quickly as possible. Printing is possible.

June (Yellow lamp illuminated): Replace with new ink or use up as quickly as possible. Printing is possible.

July (Red lamp flashing): Printing is not possible.



- The message appears on the display.

## About cartridge ink end and ink near end

When ink near end (less ink) occurs, LED "red" blinks to inform you of it. It is recommended to replace it as soon as possible.

When ink end (no ink) occurs, LED "red" is lit to inform you of it. Replace the ink cartridge.

## How to assemble ink cartridge

Before setting the ink cartridge, it is required to set the ink pack on the eco cartridge. By following the next procedures, assemble the ink cartridge.

**1**

### Open the cover of the eco cartridge.

- (1) Press the center part of the cover with your finger.
- The claw on the side without attaching part of ink IC chip comes off.



Press the center part with your finger.

- (2) Raise the cover as described in the photo.
- At this time, the claw on the ink IC chip side does not come off. Do not raise the cover forcedly so that you may not damage the claw.



- (3) Remove the remaining claw while pressing the cover as indicated in the photo, and remove the cover.

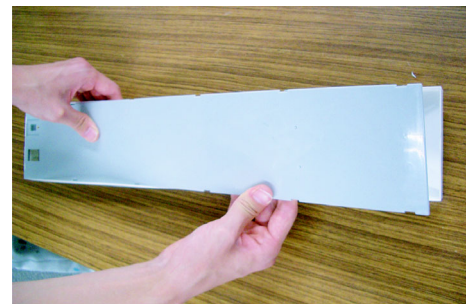

**2**

### Set the ink pack on the eco case.

- (1) Turn the side with double coated tape downward and insert the stopper.
- After inserting the stopper, push it firmly with your finger.



**1**

Before Use

(2) Peel the seal of double coated tape.



**3**

**Firmly fix the ink pack on the eco case with double coated tape so that it may not move.**

- Fix the ink pack after pulling it so that the ink pack may not go slack.



**Important!**

- Fix the ink pack so that it may not be biased in the eco case.

**Good example**

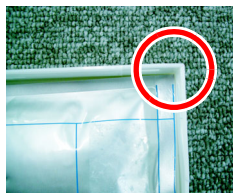

The corner of the case matches the ink pack corner.

**Bad example**



The ink pack has gone too far downward.



The ink pack goes slack in spots.

**4**

**Attach the cover.**

- Hang the claw on the IC ship side and then insert the cover into the case.



**5**

**Attach the ink IC chip.**

- Attach the ink IC chip as indicated in the photo.
- Attach it so that there is no gap in the part indicated with an arrow.

**Bad example of attaching ink IC chip**

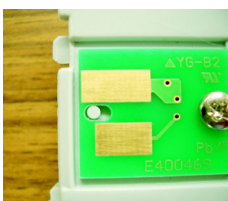

There is a gap.



The ins and the outs is reverse.

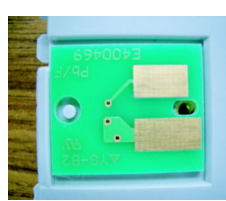

The back and the forth is reverse.

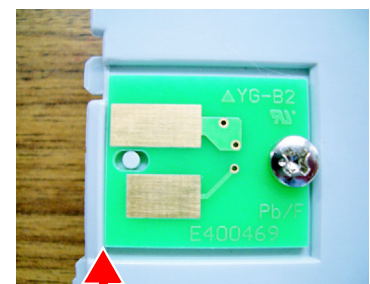

No gap shall be found.

Usable media sizes and notes for handling are described.

## Usable sizes of media

Model	JV400-130SUV	JV400-160SUV	SUJV-160
Media type	Tarpaulin/Weatherproof PVC/FF		PVC Synthetic Leather <sup>*1</sup>
Maximum width	1371mm	1620mm	
Minimum width	210mm		
Maximum printing width	1361mm	1610mm	
Roll media	Thickness	0.2mm or less	
	Roll outside diameter	φ180mm and less	
	Roll weight	25kg and less	
	Roll inside diameter	3 or 2 inches	
	Side printed	Side facing outward	
	Roll end treatment	The roll end is gently fixed to the core with weak-adhesive tape or weak glue for easy removal.	
			Before printing, check the transport test and print gap before using. <sup>*1</sup>

## Caution in handling of medias

Pay attention to the followings for handling of medias.

**Important!**

- **When handling media, wear the gloves.**  
If you touch the media with your bare hand, the media may be stained due to fingerprints or oil of your finger. Be careful about it.
- **Do not leave the media with the heater ON for a long time.**  
Waviness may occur on the media and it may cause media clogging.
- **Use media recommended by MIMAKI to ensure reliable, high-quality printing.**  
Set the heater temperature to meet the characteristics of the media.
- **Set the temperature of the Pre-heater, Print heater and Post-heater according to the type and characteristics of the media used.**  
Automatic temperature setting can be made on the operation panel by setting the profile on the dedicated RIP. For setting on the RIP, refer to the instruction manual for your RIP.
- **Pay attention to the expansion and contraction of the media.**  
Do not use media immediately after unpacking. The media can be affected by the room temperature and humidity, and thus it may expand and contract.  
The media have to be left in the atmosphere in which they are to be used for 30 minutes or more after unpacked.
- **Do not use curled media.**  
This may result in paper jamming.  
If a regular-sized coated sheet of media is rolled and stored, the coated side has to face outside.
- **Be careful to dusts on the edge face of the medium.**  
Some rolls have dusts contained in the package gathered on the edge surface of the roll. If you use as it is, the drawing quality may be degraded due to nozzle missing or ink drops. Be sure to set the roll after removing dusts adhering on the edge face of the roll.

\*1. Be careful to the following points for using the SUJV-160.

**Important!**

- **Be careful not to deform the synthetic leather due to heat.**  
Heat deformation may occur depending on the material. Be sure to perform a feeding test before printing.
- **Pay attention to the roller tracks.**  
The surface material may cause leave conveying roller tracks on the media or be poor-quality printing. Be sure to perform the feeding test and test print.
- **Pay attention to yellowing of the media caused by UV irradiation.**  
If the material has low light fastness, yellowing of the media may occur due to UV irradiation. Be sure to perform the feeding test.
- **When using media other than the recommended media (PVC Synthetic Leather), check to perform feeding tests and test printing to ensure that the following are correct:**
  - ① The media shall not be deformed or left roller tracks to the media.
  - ② No yellowing of the media due to UV irradiation.
  - ③ No problems with image quality.  
(Color unevenness, Color change, head rubbing, ink-ball, etc.)

# About antistatic sheet

JV400-130SUV: three antistatic sheets, JV400-160SUV, SUJV-160: four antistatic sheets are attached in this machine.

The electrostatic sheet is used to prevent the media from clinging due to static.

Use this when static or deflection of the media on the post heater occurs and affects the media feeding.

## ● Fix the electrostatic sheet

Hang the claw of the antistatic sheet on the groove of the platen.

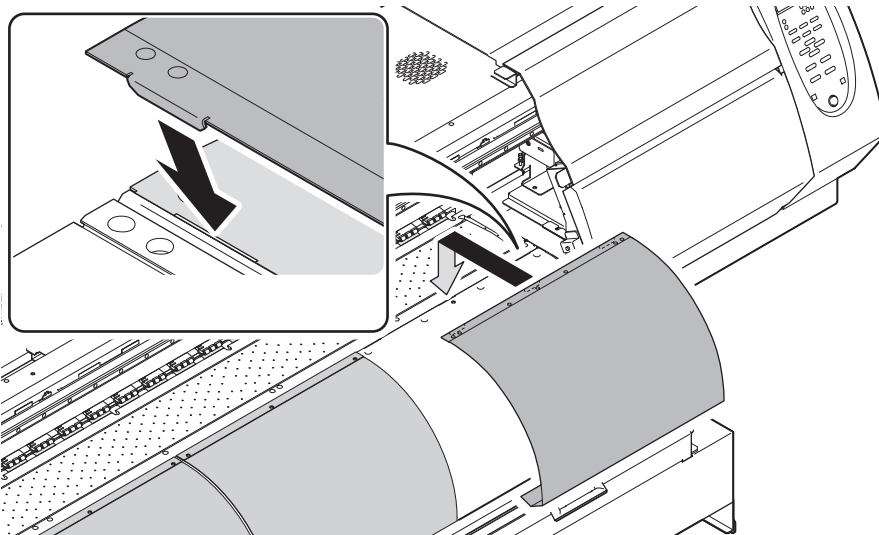

## ● Remove the electrostatic sheet

Remove it in the reverse procedures of assembling, and use it with pasted on the magnet of the back side of the UV lamp unit.

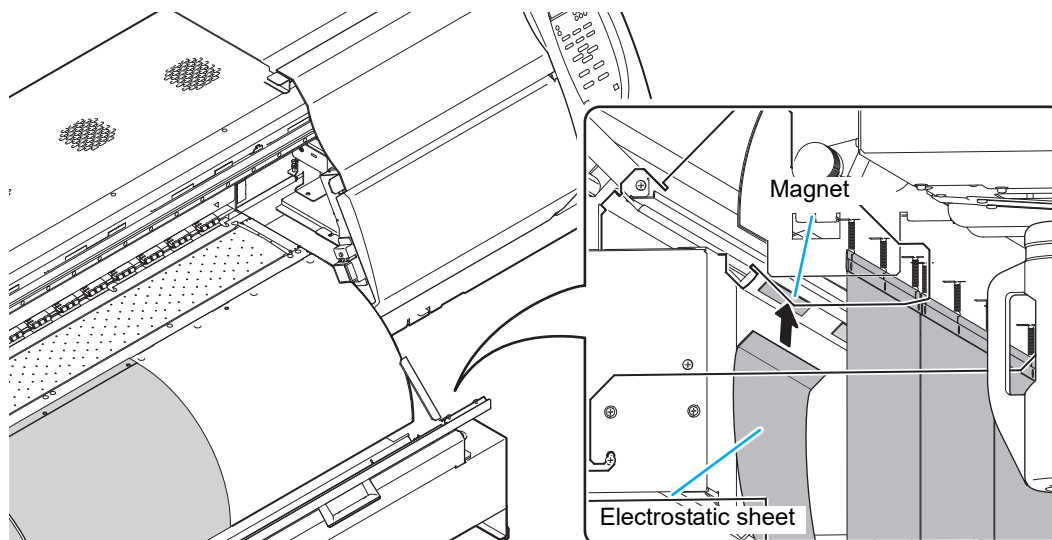

1

Before Use

If you removed the antistatic sheet, attach the sheet holder on the platen (JV400-130SUV: three positions / JV-400-160SUV, SUJV-160: four positions).

If you do not attach the sheet holder, the heater temperature drops and drying may become not enough.

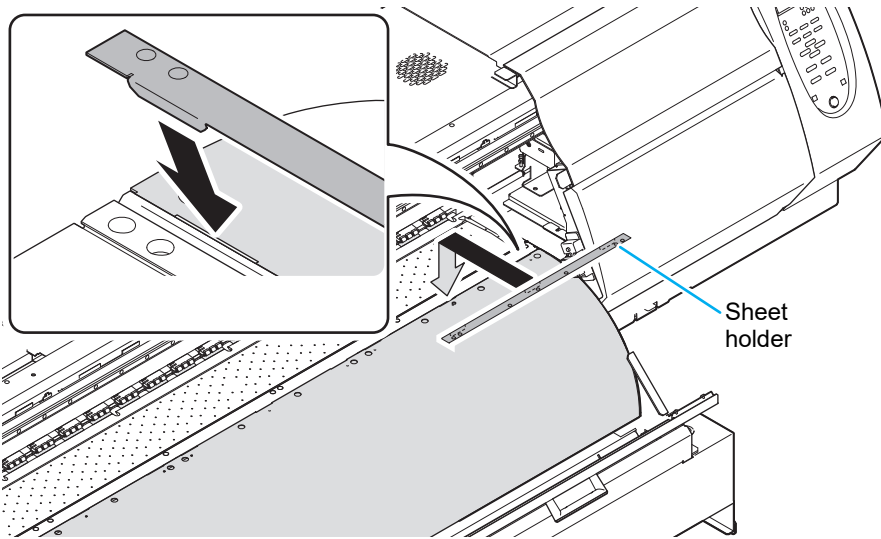



# Chapter 2

## Basic Operations



### This chapter

describes procedures and setting methods for ink and media preparation, and printing.

Workflow .....	2-2	Head Cleaning .....	2-19
Turning the Power ON/OFF .....	2-3	About head cleaning .....	2-19
Turning the Power ON .....	2-3	Perform head cleaning depending on the test	
Turning the Power OFF .....	2-4	printing result .....	2-19
Setting a Media .....	2-5	Set the media feeding .....	2-20
Adjusting the Head Height .....	2-5	Setting Feed Correction .....	2-20
Note for media setting .....	2-7	Correct the ink drop position for bidirectional	
Setting a roll media .....	2-8	printing .....	2-22
Take-up device .....	2-12	Printing Data .....	2-24
Changing the printing origin .....	2-13	Starting a Printing Operation .....	2-24
Preparing for the Heaters .....	2-14	Stopping a printing operation halfway .....	2-25
Changing the Temperature Settings for the		Deleting Received Data (Data Clear) .....	2-25
Heaters .....	2-14	Behavior after printing has been completed .....	2-25
Checking the Heater Temperature .....	2-15	Cutting a media .....	2-27
Test Feeding .....	2-16		
Test Printing .....	2-17		
Test Printing .....	2-18		

# Workflow

**1** Turning the Power ON/OFF

Referring to “Turning the Power ON/OFF” (☞ P.2-3).

**2** Setting a Media

Referring to “Setting a Media” (☞ P.2-5).

**3** Preparing for the Heaters

Referring to “Preparing for the Heaters” (☞ P.2-14).

**4** Test Printing

Referring to “Test Printing” (☞ P.2-17).

**5** Set the media feeding

Referring to “Set the media feeding” (☞ P.2-20).

**6** Correct the ink drop position for bidirectional printing

Referring to “Correct the ink drop position for bidirectional printing” (☞ P.2-22).

**7** Printing Data

Referring to “Printing Data” (☞ P.2-24).

# Turning the Power ON/OFF

## Turning the Power ON

This machine is provided with the following two power switches:

**Main power switch:** Two switches are located on the side of this machine. Keep this switch ON all the time.

**Power switch :** Normally, use this switch to turn the power ON/OFF.

The power switch lights in green when the power is ON.

### 1 Turn the main power switch ON.

- Set the two main power switches located on the side of this machine to the "I" side.

### 2 Turn the power switch ON.

- Push the power switch located on the operation panel.

- The firmware version is displayed when the power is turned ON.
- The machine performs its initial operation.

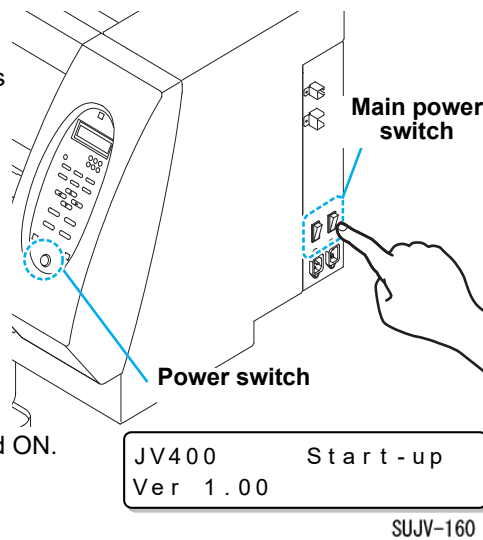

### 3 The machine enters LOCAL.

<LOCAL>

### 4 Turn ON the power of the connected PC.

**Important!**

- Turn the power ON after the front cover and maintenance cover are closed.
- Use the machine with always turning "ON" the main power. The function preventing nozzle clogging operates automatically to protect the head of the nozzle.
- The head nozzle may result in nozzle clogging if the main power switch is left OFF for a long time.

2

Basic Operations

## Turning the Power OFF

When having ended the operation of the machine, turn the power OFF by pressing the power switch located on the front side.

Check the following items when turning the power OFF.

- If the machine is receiving data from the PC or if there is any data that has not been output yet
- If the head has returned to the capping station
- If any error has occurred (☞ P.5-15 “Error messages”)

### 1 Turn OFF the power of the connected PC.

### 2 Press the power switch to turn the power OFF.

- Do not turn OFF the main power switch located on the side of the machine.
- To use this machine again, light the green lamp by pressing the power switch.

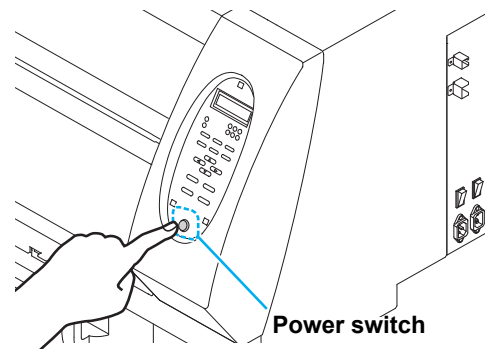

## Cautions about Turning the Power OFF

### ● Do not turn the main power switch OFF.

When the main power switch is ON, the power periodically turns ON and the nozzle clogging prevention function (flushing function) and the pressure adjusting function operate.

When the main power switch has been turned OFF, the auto maintenance functions, such as flushing, do not operate, and this may cause nozzle clogging.

### ● Keep the front cover and the maintenance cover closed.

If the cover is opened, the auto maintenance function such as the flushing function does not work.

### ● Turn the power OFF after having checked the position of the head.

If the power is turned OFF in a state where the head has not returned to the capping station, the head dries, which may cause nozzle clogging.

In this case, turn the power ON again and check that the head has returned to the capping station, and then turn the power OFF.

### ● Do not turn the power OFF during printing.

The head may not return to the capping station.

### ● After having turned the power switch OFF, turn the main power switch OFF.

When turning the main power switch off for moving the machine or for solving the error or the like, press the power switch on the front of the machine, check the display is turned off on the operation panel, and then turn the main power switch off.

# Setting a Media

This machine can be used with a roll media only.  
For usable medias, refer to P.1-17 "Usable sizes of media".

## Adjusting the Head Height

Adjust the head height according to the thickness of the media you use.

**Important!**

- Perform this work after turning OFF the heater and the temperature becomes low enough.
- Adjust the head height prior to setting the media. If the head height is adjusted after the media is set, this may cause a media jamming, deterioration of the print quality or head damage.
- The range of the initial head height is adjustable by 3 levels according to the purpose of use.
- The range of the printing height of JV400 and SUJV-160 is from L (1.8 mm), M (2.3 mm), H range (2.8 mm). (Set to L range 1.5 mm at shipping)

### 1 Move the carriage to the platen.

- When the device is turned ON :Execute [STATION - CARRIAGE OUT] of the Maintenance functions. (☞ P.4-6 Step1,2)
- When the device is turned off : Open the front cover, then move the carriage by hand.

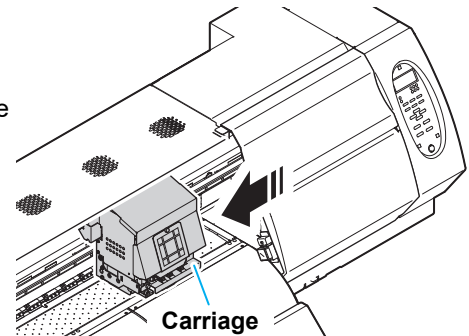

### 2 Loosen two screws located at the front.

- Loosen the screws, rotating each by one turn of a standard screwdriver.

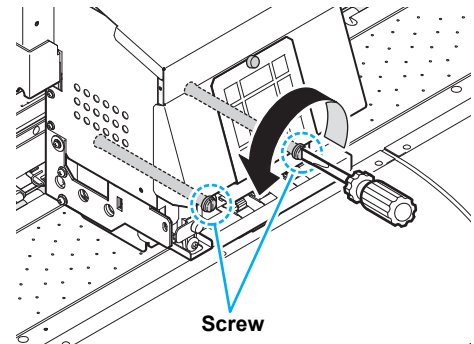

### 3 Rotating the lever of the right side of the carriage.

- Turn the lever left (towards you) to lower the carriage and turn the lever right (towards the back) to raise it.

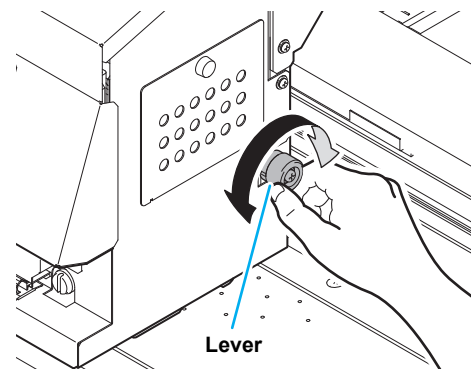

2

Basic Operations

**4**

**Fix the carriage.**

- Fastening the screw in front, you can fix the carriage.
- Fasten the screw securely.

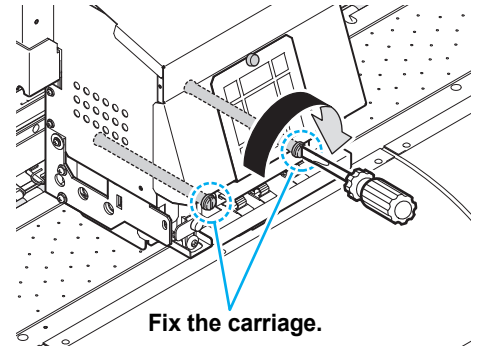

**5**

**Return the carriage to the station position.**

- When the power supply is off, return the carriage to the station manually.
- When the power supply is on, press the **ENTER** key if the screen below is displayed.

STATION  
COMPLETED [ ENT ]

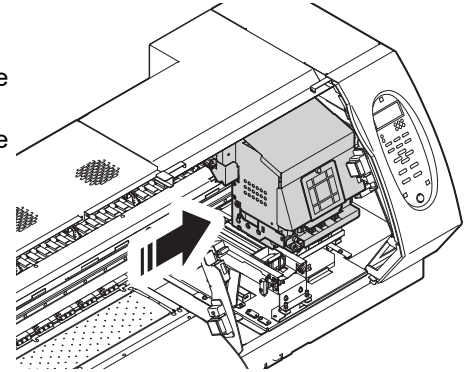

**6**

**Close the front cover.**

## Note for media setting

When setting media, read the following notes carefully.



- Take care not to drop the media on a foot or so when the media is set. It may cause an injury due to the media.
- The roll stopper arm works with the clamp lever. Do not push the clamp lever down while roll stopper is caught between the roll stopper arm and this machine. The roll stopper arm might be broken and roll stopper function <sup>\*1</sup> might be disabled.

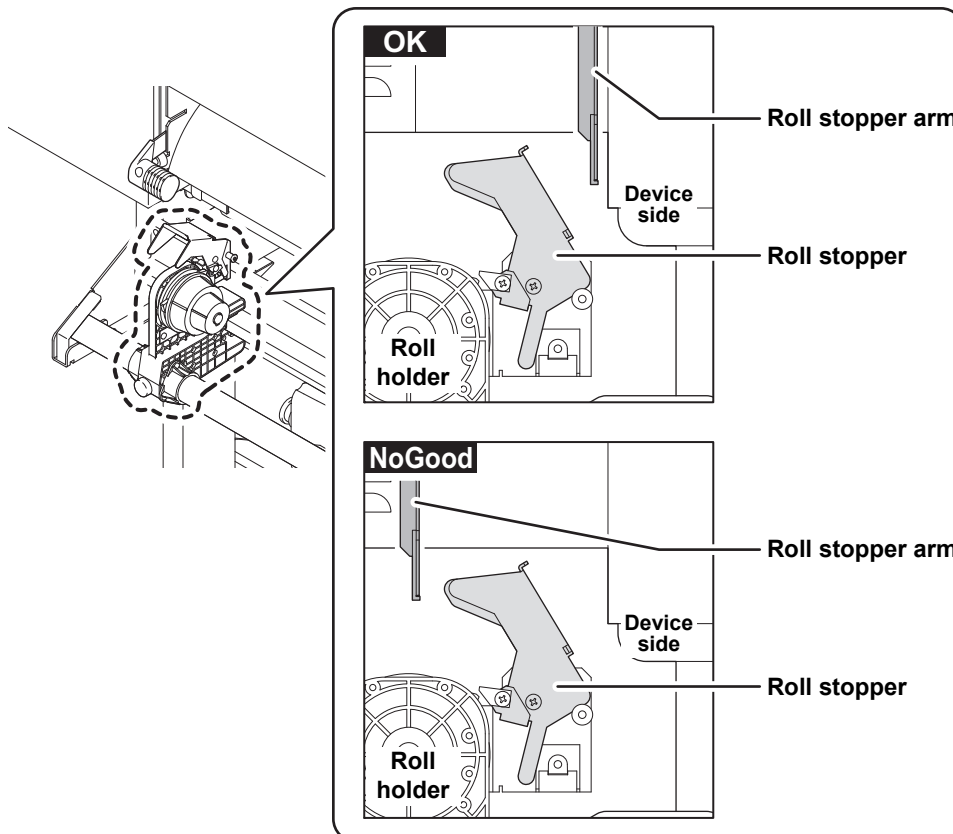

\*1. The function that once pulled out a certain amount of media, media pullout is temporarily locked.

## Setting a roll media

- 1 Move the roll holder located in the back of the device to the direction of the middle of the device.

- Loosen the roll holder fixing screw and then move it.

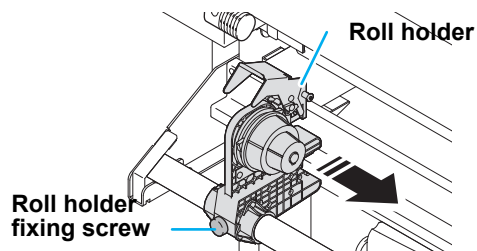

- 2 Check the clamp lever located in the back of the device is lowered.

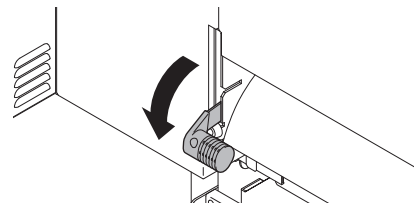

- 3 Move the roll holder to the roll setting position.

- Check the roll stopper is not caught between the roll stopper arm and this machine.

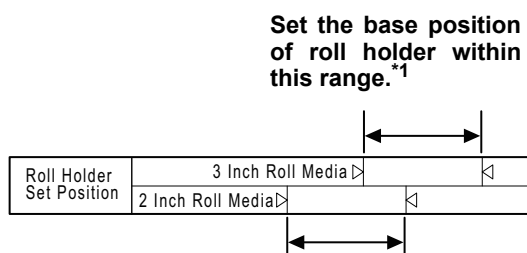

- There are two types of the internal diameter of the roll media paper tube: 2 inch and 3 inch.

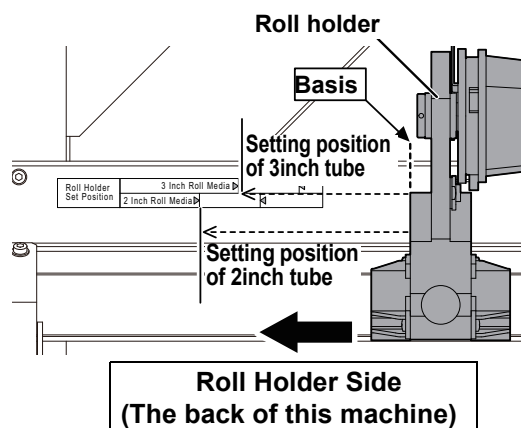

\*1)In case of using media with settable maximum width, set this so that the media width can be more inside than ▽ ▽.

- If a media is misaligned to the right/left more than fixed position, a warning is displayed. Set the media again.

ERROR 516  
MEDIA SET POSITION R

ERROR 516  
MEDIA SET POSITION L

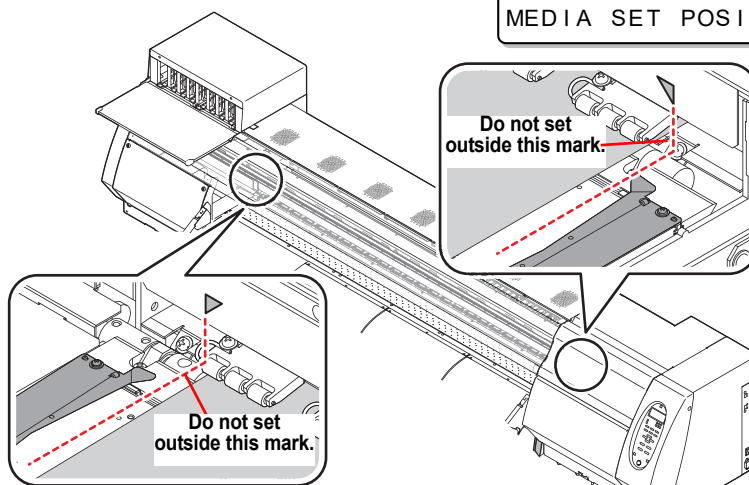



**4** Tighten the roll holder fixing screw.

- Check the Step 2 to 3 again.

**5** Set the left end of the core of the roll media on the left roll holder.

- Push the roll media onto the roll holder until the roll core is all the way seated.

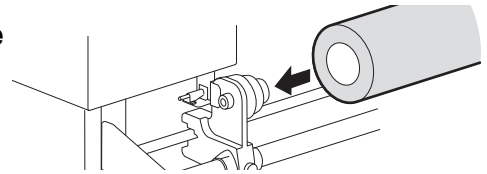
**6** Loosen the screw of the right side roll holder then insert the holder into the core of the roll media.

- When the roll holder is not firmly pressed against the core of the roll media, the feeding media may be loosened and thereby the media reaches to the floor. (☞ P.5-11)

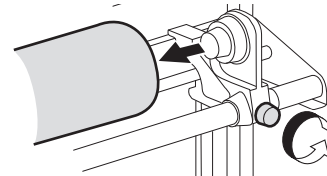
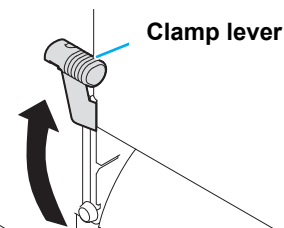
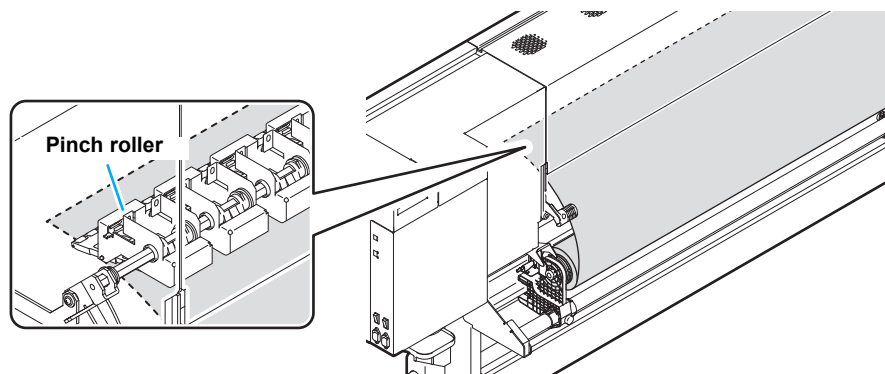
**7** Tighten the screw of the roll holder**8** Raise the clamp lever in the front of this machine.**9** Insert the roll media in this machine.

- The roll media can be smoothly inserted by slanting the media.

- (1) Pull the media out of the roll to the head of the platen.
- (2) Insert the media between the platen and the feed roller.
  - Pull the media out of the roll so that the media can be grasped from the front of the machine.
- (3) Push down the clamp lever from the back of this machine.
  - The media is held.

# 10

## Pull out the roll media out.

- (1) Open the front cover and the shading cover.
- (2) Raise the clamp lever from the back of this machine.
- (3) Pull out the roll media gently and then stop pulling when locked lightly.

**Important!**

- When setting a medium, be sure to cover the medium sensors located on the rear of the platen. The media cannot be detected unless it is placed over the sensor.

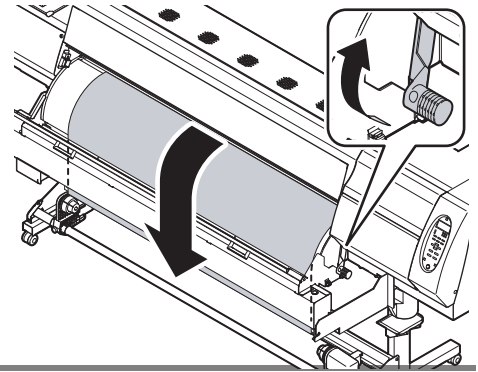

# 11

## Make the roll media even then lower the clamp lever.

- Pulling several positions of the media lightly, Lower the clamp lever after confirming that the amount of the roll media pulled out is almost even.

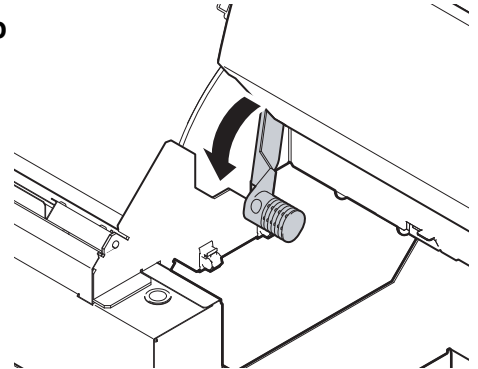

# 12

## Hold the media with the media press gently.

- Set the media so that no media sticks out from the right end pinch roller to the right side.
- When using a thick media, remove the media press from the media before printing.

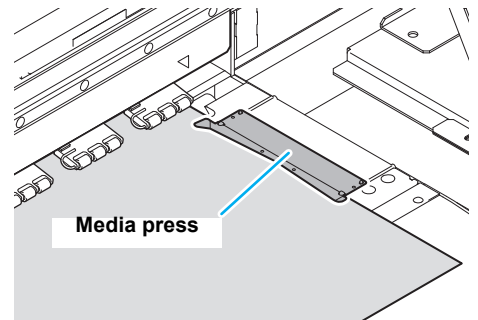

- In case that you use 240mm-wide media, media cannot be detected if it is set in accordance with ▽. Set media approximately 30mm inner than ▽.
- Do not set the media outside ▽. As media may tilt and be lifted, it could break the head.

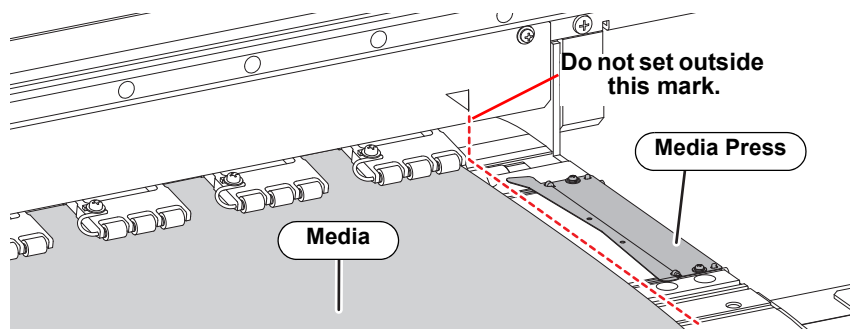

- If a media is misaligned to the right more than fixed position, a warning is displayed. Set the media again.

ERROR 516  
MEDIA SET POSITION R

**13** Hold the media with the media guide gently.

- If the printing result indicates that drying is not enough, use the media guide to improve adhesion of the media to the platen.
- Use the media guide with it hit slightly against the sheet holder.
- Make the media pass around the center of the claw of the media guide.

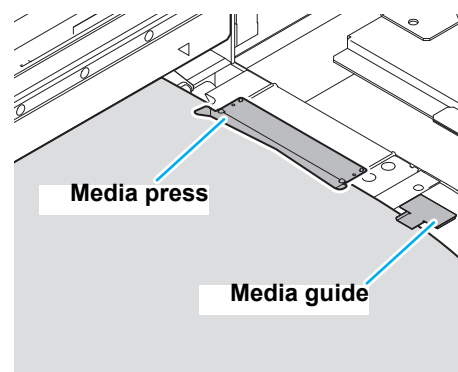
**14** Prepare for the take-up device.

- (1) Set an empty core of the roll media on the take-up device.
- (2) Close the front cover.
- (3) Close the shading cover.

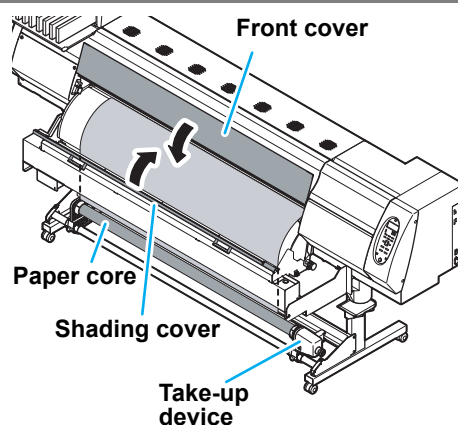

**15** Press the   key to detect the media width.

- Detects the media width.
- When [MEDIA RESIDUAL] of the machine setup is "ON" (☞ P.3-14), the screen for entering media remaining amount is displayed after detecting the media width. (☞ P.2-12)

MEDIA DETECT

[ &lt;/&gt; ]

**16** Fix the media on the take-up device.  
(☞ P.2-12)

- (1) Feed the media up to the core of the roll media of the take-up device by pressing the  key.
  - Check the media end is not caught into the slot on the post-heater, and then feed the media.
- (2) Fix the middle of the media with adhesive tape.
- (3) In the same manner, fix the left side and right side of the media.
  - Make sure that there is no slack or wrinkle on the media in such condition that the roll media is pulled to right and left evenly, and then stick the tape.
- (4) Press the  key.

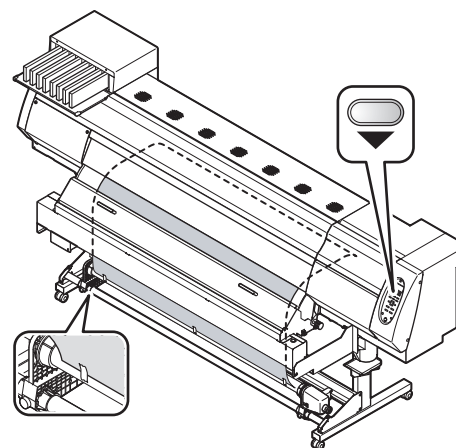

- Depending on the media to use, attach/ remove the antistatic sheet. (☞ P.1-19)
- If media floats at the detecting position, it may not be detected correctly.
- When you print, be sure to use the take-up device.

## Entering the media remaining amount

When [MEDIA RESIDUAL] of the maintenance function is "ON" (☞ P.3-14), the screen for entering media remaining amount is displayed after detecting the media width.

- 1

**Display the screen for entering media remaining amount.**

Input of MediaLength  
= xxx.xm

---

- 2

Press and key to enter the media remaining amount.

Input of MediaLength  
= 50.0m

---

- 3

Press the key.

## Take-up device

With the switch of the take-up device, select the take-up direction of the media or others.

Lever in top position (REVERSE) :

The take-up device winds the media with the printed side facing in.

Lever in middle position (OFF) :

The take-up device does not wind the media.

Lever in bottom position (FORWARD) :

The take-up device winds the media with the printed side facing out.

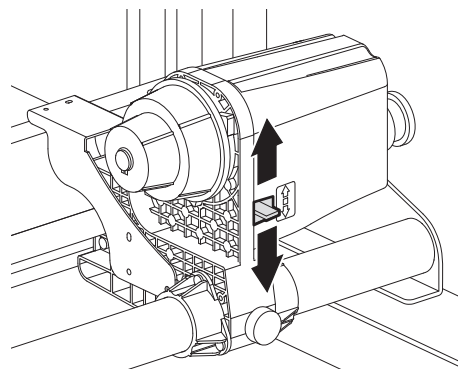

## Setting the torque limiter

The take-up device is provided with a torque limiter.

The take-up torque can be adjusted with the torque limiter.

(The torque limiter is set at the maximum value when shipped from the factory.)

If the tension is too strong to use a thin sheet of media, lower the take-up torque with the torque limiter.

- Clockwise turn : Increases torque (a heavy and thicker media such as tarpaulin or the like)
- Counterclockwise turn : Decreases torque (For light media)

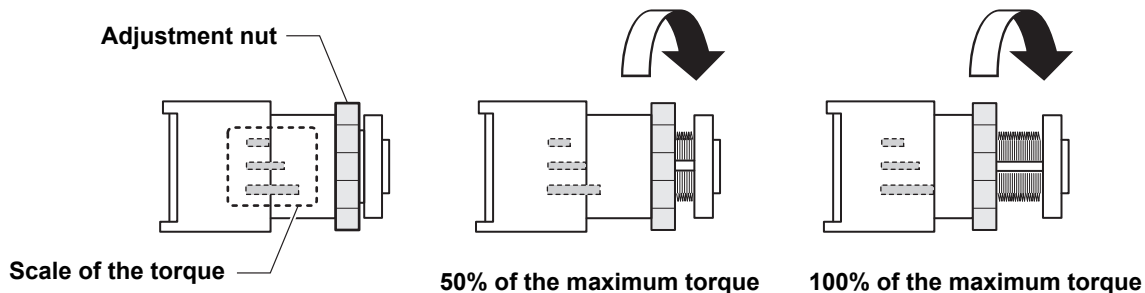

**Important!**

- **When the torque limiter is adjusted too weak ;**  
The media can not be taken up firmly.
- **When the torque limiter is adjusted too strong ;**  
The slack may occur depending on the media and cause influence on the image quality.





## Changing the printing origin

The position of the printing origin can be changed.  
Moving the LED pointer to the changing position and deciding the position.

- 1** In Local, Press    .
- It enters into the origin setting mode.

```
ORIGIN SETUP
0.0      - - - -
```

- 2** Set a light point of the LED pointer to the changing position by pressing    .

- Select the carriage and media, moving the point with    .
- When you press the  key here, you can perform media cutting.

```
ORIGIN SETUP
0.0      0.0
Origin   Origin
(Length) (Width)
```

- 3** After determining the origin, press the  key.
- The printing origin is changed.

```
ORIGIN SETUP
* * ORIGIN * *
```

### Typical setting position of printing origin

The printing origin in the depth direction (X') is positioned at about 75 mm rearward from the slot for cutting on the platen. The printing origin in the scanning direction (Y') is positioned at 15 mm from the right end of the media. The value in the scanning direction (Y') can be changed using [MARGIN] in FUNCTION mode. (P.3-6) This can be changed by using the Jog key.

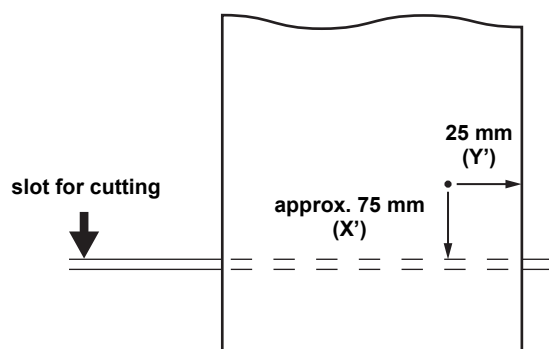

# Preparing for the Heaters

## Changing the Temperature Settings for the Heaters

Set the heater temperature.

Depending on the media and the profile to use, set the heater temperature.

- It may take several minutes to tens of minutes for the set temperature to be reached, depending on the ambient temperature.



- You can change the temperature set here also in [HEATER] of the [SETUP] menu. (☞ P.3-2)

1

Press the **HEATER** key.

PRE	PRT	POST
23 °C	23 °C	23 °C

Heater temperature  
confirming display

2

Press the **HEATER** key.

The set temperature: 20 to 70°C

OFF	OFF	OFF
( 23 °C	23 °C	23 °C )

3

Press **▲** **▼** **◀** **▶** to set the temperature of each heater.

Heater selecting: Select with **◀** **▶**  
Temperature setting: Set with **▼** **▼**

OFF	OFF	OFF
( 23 °C	23 °C	23 °C )

Current heater temperature

- The heater starts to get hot. (The [HEAT] lamp lights in orange.)
- When the heater temperature reaches the set temperature, the [HEAT] lamp goes off and the [CONSTANT] lamp lights in green.

4

Press the **ENTER** key to end the setting.



- The Heater temperature is controllable at the RIP side if the RIP in use has a function controllable. (For the setting procedures, refer to the instruction manual of the RIP in use.)
- Depending on the power supply voltage, amount of heat generation differs. For the power supply voltage of 100V to 120V, it may not reach 70 °C.
- If you set [VACUUM] of the [SETUP] menu more than needs, it may cause temperature decrease of the print heater.



- Use this machine under 20 to 30°C. The temperature may not reach the set value due to the environmental temperature condition.

## Checking the Heater Temperature

**1**

Press the **HEATER** key.

- The current heater temperature is displayed.

PRE	PRT	POST
40 °C	50 °C	35 °C















**2**

Press the **END** key at the end of confirmation.

- The screen returns to LOCAL.

# Test Feeding

Since heater is used at high temperature, cockles may occur in some of your media. (☞ P.5-11)  
Perform this function before printing, and check whether the media can be fed normally.

- 
- |          |  |                      |
|----------|--|----------------------|
| <b>1</b> | <b>Press the  key in LOCAL three times.</b> | TEST FEED<br>[ ENT ] |
|----------|--|----------------------|
- 
- |          |   |                       |
|----------|---|-----------------------|
| <b>2</b> | <b>Press the  key.</b> | BACKWARD FEED<br>: ON |
|----------|---|-----------------------|
- 
- |          |  |                       |
|----------|--|-----------------------|
| <b>3</b> | <b>Press   to select ON/OFF.</b> | BACKWARD FEED<br>: ON |
|----------|--|-----------------------|
-  • When setting "ON", rewind the roll media to take up the slack before printing.
- 
- |          |   |                 |
|----------|---|-----------------|
| <b>4</b> | <b>Press the  key.</b> | UV LAMP<br>: ON |
|----------|---|-----------------|
- 
- |          |   |                  |
|----------|---|------------------|
| <b>5</b> | <b>Press   to select OFF.</b> | UV LAMP<br>: OFF |
|----------|---|------------------|
-  • When "Manual Drying Feed" is operated, select "ON". (☞ P.2-26)
- 
- |          |   |                            |
|----------|---|----------------------------|
| <b>6</b> | <b>Press the  key.</b> | TEST FEED<br>START [ ENT ] |
|----------|---|----------------------------|
- 
- |          |   |                                  |
|----------|---|----------------------------------|
| <b>7</b> | <b>Press the  key.</b> | ** TEST FEED **<br>PLEASE : WAIT |
|----------|---|----------------------------------|
- Start test feeding.
-  • For "manual Drying Feed", when you open the shading cover while the UV lamp lights, the UV lamp is turned off. However, the operation will continue.
- 
- |          |   |  |
|----------|---|--|
| <b>8</b> | <b>Press the  key.</b> |  |
|----------|---|--|
- The feeding operation is continued until you press the  key.
- Feed it to some extent and check the feeding status, and then press the  key to terminate.
-



# Test Printing

Print a test pattern to check that there are no discharging defects such as nozzle clogging (slight touching of ink or nozzle missing).

## Relationship between head row and test pattern

The relations between head row and test pattern print position are as follow.

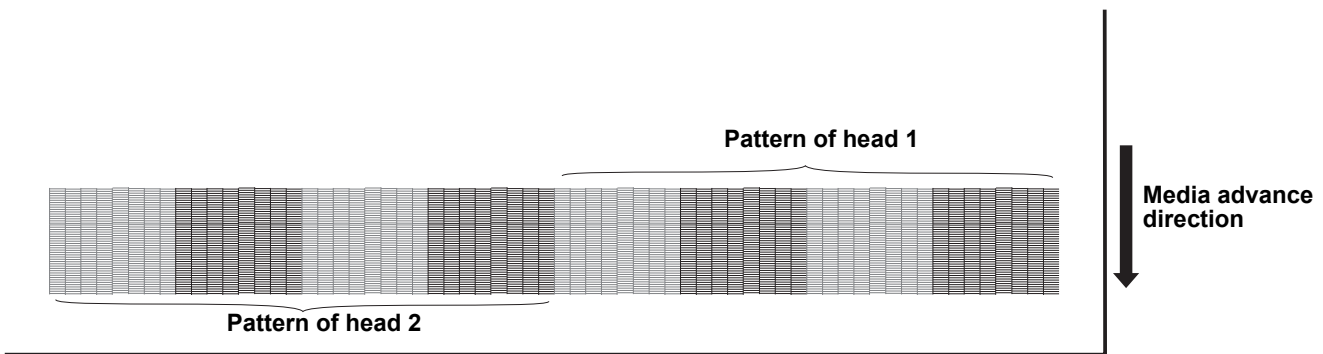
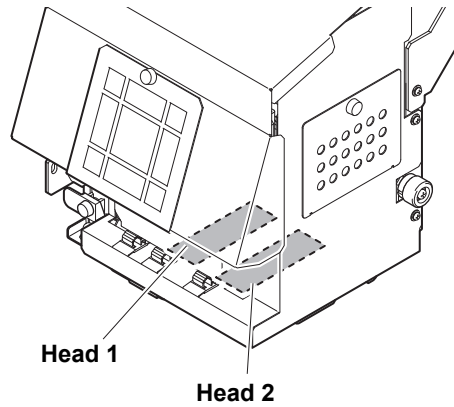

## Note on test printing

**Important!**

- When using a roll medium, rewind the medium by hand before printing so that it is not loose. When the roll medium has not been rewound tightly, it may cause image quality to deteriorate.

## Test Printing

Print a test pattern to check that there are no discharging defects such as nozzle clogging (slight touching of ink or nozzle missing).

In addition, you can select the orientation of the test pattern to print from two types in order to perform test printing repeatedly. Select one depending on your use.



- Prepare the media 250mm wide and 350mm or longer length for printing test patterns.

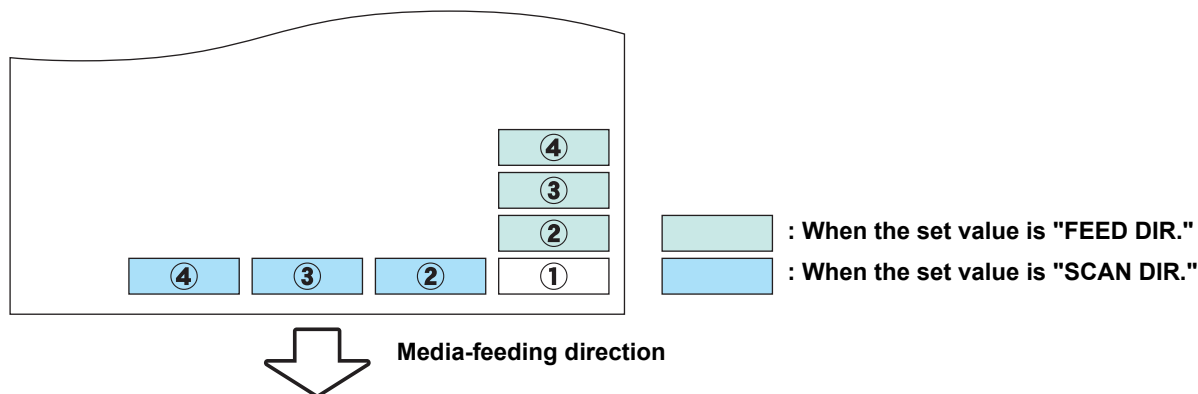

<b>Check before test printing.</b>	• If a media has been set (☞ P.2-5)	• If the origin position has been set
	• If the head height has been adjusted (☞ P.2-5)	

**1** Press the **TEST PRINT/CLEANING** key in **LOCAL**.

- Press **▲** **▼** to change the test pattern orientation.

TEST PRINT  
 (SCAN DIR.) [ENT]

**2** Press the **ENTER** key.

- Test printing starts.
- When the printing has been completed, the screen returns to step1.

\*\* PRINTING \*\*  
 PLEASE WAIT

TEST PRINT  
 (SCAN DIR.) [ENT]

**3** Check the printed test pattern.

- When the result is normal, end the operation.
- When the result is abnormal, perform head cleaning. (☞ P.2-19)

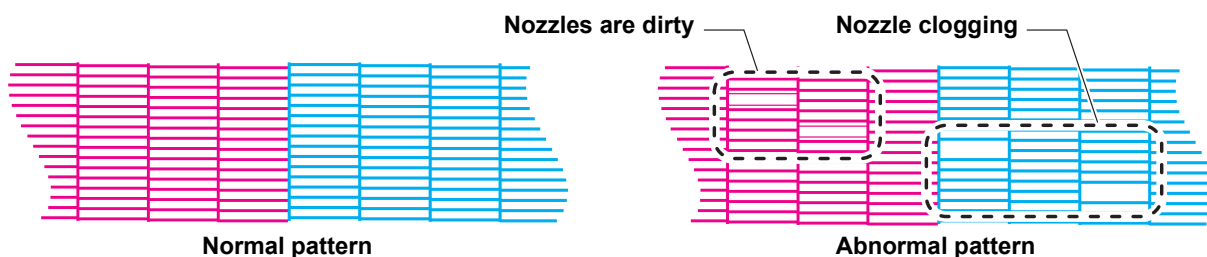

- When using the nozzle recovery function (☞ P.4-28), if the feed corrections do not match, printing is done with the recovered nozzle sections misaligned. In that case, perform a feed correction (☞ P.2-20) and then perform the test print again.

# Head Cleaning

## About head cleaning

Check the printed test pattern result and perform cleaning depending on the status.  
Select one from the three types below:

- SOFT** : When lines are bent, when any line is missing
- NORMAL** : When any line is missing, when colors are mixed
- HARD** : When poor image quality cannot be improved even by NORMAL or SOFT cleaning

## Perform head cleaning depending on the test printing result

There are three types of head cleaning. Use one by checking the test pattern.

**1** In Local, Press the **CLEANING** key two times.

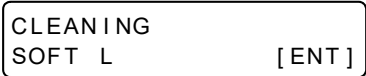

**2** Press **▲▼** to select the cleaning type.

- SOFT** : When lines are bent, when any line is missing
- NORMAL** : When any line is missing, when colors are mixed
- HARD** : When poor image quality cannot be improved even by NORMAL or SOFT cleaning



**3** Press the **ENTER** key.



**4** Press **▲▼◀▶** to select a head to cleaning.

- Set Value : 12 (Cleaning both heads.)  
1\_ (Cleaning Head 1 only.)  
\_2 (Cleaning Head 2 only.)

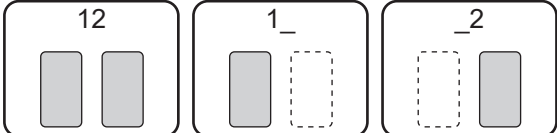

**5** Press the **ENTER** key.

- On completion of cleaning, the screen returns to step1.



**6** Perform test printing again, and check the result.

- Repeat the cleaning and the test printing until the drawing result becomes in normal.



### When the image quality is not improved after the head cleaning.

- Clean the wiper and ink cap. (☞ P.4-6)
- Wash the head nozzle. (☞ P.4-23)
- Solve the failure of the image quality, referring to When Nozzle Clogging Cannot Be Solved. (☞ P.4-23)

# Set the media feeding

Correct the feeding rate of media.

If the correction value is not appropriate, stripes may appear on the printed image, thus resulting in a poor printing.

**Important!**

- When you have changed the media type, check the pattern and perform adjustment depending on the status.
- When you have changed the temperature of the heaters, make sure that the [CONSTANT] lamp lights up and that the preset temperature is reached, and then start the correction.
- When using a roll medium, rewind the medium by hand before printing so that it is not loose. When the roll medium has not been rewound tightly, it may cause image quality to deteriorate.
- When printing with a take-up device, set the media first and then perform media correction.

## Setting Feed Correction

A pattern for media correction is printed and a media-feeding rate is corrected.



- Two bands are printed in the correction pattern.
- Make adjustment so that an even color density is obtained in the boundary between the two bands.

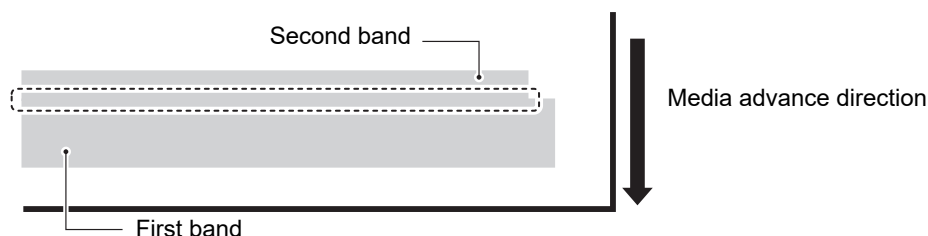

**1**

Set a media. (👉 P.2-5)

**2**

Press the **ADJUST** key in LOCAL.

FEED COMP .  
<ENT>

**3**

Press the **ENTER** key.

FEED COMP .  
PRINT [ENT]

**4**

Press the **ENTER** key to print a correction pattern.

\*\* PRINTING \*\*  
PLEASE WAIT

**5**

Check the correction pattern and enter a correction value.

FEED COMP .  
= 0

Enter a correction value in "+": The boundary between the two bands is widened.

Enter a correction value in "-": The boundary between the two bands is narrowed.

Entry example: **Entry example: When the patterns overlap**

  
When entering the value in "+"

0

**When one pattern is away from the other**

  
When entering the value in "-"

6

Press the **ENTER** key.

- Print a correction pattern again and check it.
- When media correction is needed, perform the operation in Step 5 to make correction.

```
FEED COMP .
PRINT [ENT]
```

7

Press the **END** key several times to end the setting.

## Performing the feed correction without **ADJUST** key

You can select "FEED COMP." by using the **FUNCTION** key in the Local without pressing the **ADJUST** key.

Press the **FUNCTION** key in Local.

Press **▲** **▼** to select [SETUP].

Press the **ENTER** key twice.

- It becomes the same condition as the key is pressed from Local.

## Correcting Media-feeding during Printing

A media-feeding rate can be corrected even in the remote mode or when image data is printed.

1

Press the **FUNCTION** key in the Remote.

```
*REMOTE*
** . **mm
```

```
FEED COMP .
0 ▶ 0
```

Current [FEED COMP.] value

2

Press **▲** **▼** to enter a corrected feeding rate.

- Corrected feeding rate: -255 to 255
- The value entered here is reflected in the corrected feeding rate soon.

3

Press the **ENTER** key.

- The changed value is registered.
- When you press the **ENTER** key instead of the **END** key, the value entered here will be invalid.

```
*REMOTE*
** . **mm
```

# Correct the ink drop position for bidirectional printing

When the condition for printing (media thickness/head height/etc.) has been changed, perform the following operation to correct the ink drop position for bidirectional (Bi) printing and obtain the proper printing result.

## Example of a Drop Position correct Printed Pattern

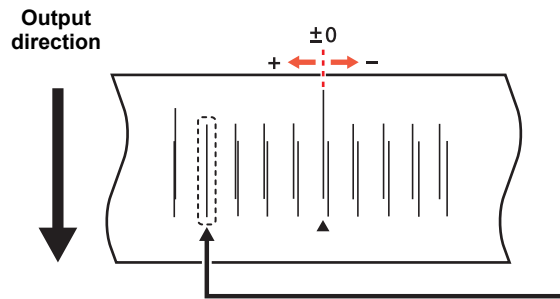

The dots at the fourth position counted from the zero position in the positive direction form a straight line. In this case, the dot position correction value is 4.0.

**1**

Set a media on the machine and set a printing origin. (👉 P.2-5)

**2**

Press the **ADJUST** key twice in LOCAL.

DROP.POScorrect  
[ENT]

**3**

Press the **ENTER** key.

DROP.POScorrect  
:Y600dpi

**4**

Press **▲** **▼** to select the resolution.

- Setting value: Y600dpi / Y900dpi / Y1200dpi
- Perform correction for all resolutions.

DROP.POScorrect  
:Y600dpi

**5**

Press the **ENTER** key.

DROP.POScorrect  
PRINT [ENT]

**6**

Press the **ENTER** key to start pattern printing.

- Test pattern is printed. (The printed patterns are called Pattern 1, Pattern 2, Pattern 3... in the order of printing.)

\*\* PRINTING \*\*  
PLEASE WAIT

**7**

Press **▲** **▼** to correct the dot position of Pattern 1~.

- Corrected feeding rate: -40.0 to 40.0
- Check the test patterns. The position where an outward feeding line and a return feeding line become one straight line is the correction value.
- When the correction value is not between -40.0 and 40.0, adjust the height of the printing heads and then perform the operations in Step 2 and later.

PATTERN1  
= 0.0

**8**Press the **ENTER** key.

- Next test pattern is printed.
- Repeat step6 and step7.

**9**Press the **END** key several times to end the setting.

### Performing to correct the dot position without **ADJUST** key

You can select "DROP.POScorrect" by using the **FUNCTION** key in the Local without pressing the **ADJUST** key.

Press the **FUNCTION** key in Local.

Press **▲** **▼** to select [SETUP], and press the **ENTER** key.

Press **▲** **▼** to select [DROP.POScorrect], and press the **ENTER** key twice.

- It becomes the same condition as the key is pressed from Local.

**2**

# Printing Data

## Starting a Printing Operation

**Important!**

- When using a roll media, rewind the media by hand before printing so that it is not loose. When the roll media has not been rewound tightly, it may cause the image quality to deteriorate.

### 1

#### Setting a Media (☞ P.2-5)

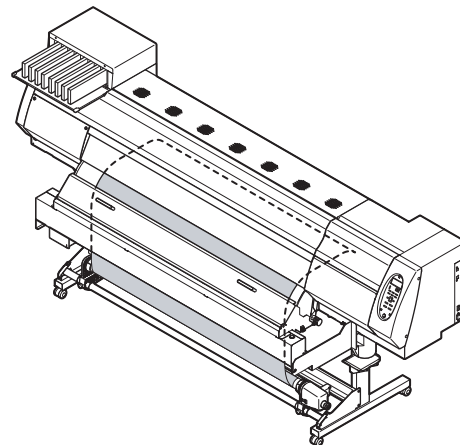

### 2

#### Checking the Heater Temperature

- Check the CONSTANT lamp lights in [PRE], [PRINT], and [POST] below the display.

ACTIVE  
○

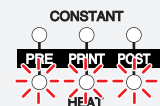

### 3

#### Press the **REMOTE** key in LOCAL.

- If the heater temperature has not reached the setting value, or, the machine is waiting for the UV lamp lights and temperature to rise, the right screen is displayed. Even if it has not reached, you can move to REMOTE when pressing the **ENTER** key.
- The screen changes to REMOTE, and data can be received from the PC.



- It takes 30 seconds to light up the UV lamp.

TEMPERATURE CONTROL!  
PLEASE WAIT



UV LAMP  
PREPARING

### 4

#### Transmit data to be printed from the PC.

- The ACTIVE lamp blinks and the printing conditions are displayed.
- For the method of data transmission, see the instruction manual for the output software.

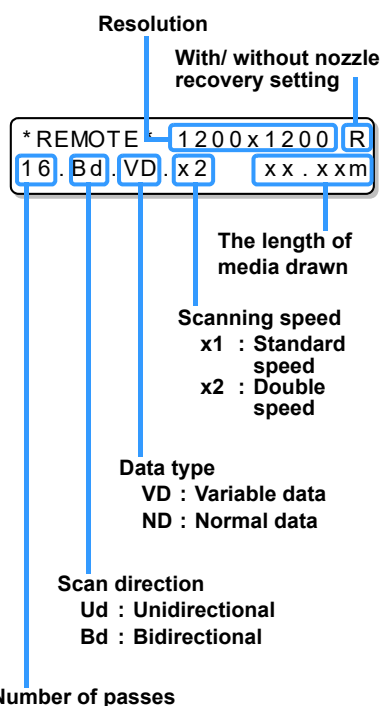

### 5

#### Start printing.

**Important!**

- if you open the shading cover during printing, the printing operation is terminated and the machine returns to the local display. At this time, the UV lamp is turned off.



## Stopping a printing operation halfway

Perform the following operation when stopping a printing operation halfway.

**1** Press the **REMOTE** key during printing.

- The printing operation stops.
- Interrupt data sending at the PC side during the data is sent from the PC.
- Printing restarts from the interrupted data by repressing the **REMOTE** key.

<LOCAL>  
width: 1272mm



- When printing operation stops, the UV lamp is OFF.
- It takes 30 seconds to light up the UV lamp.

## Deleting Received Data (Data Clear)

When you want to stop printing, delete the already received data.

**1** Press the **DATA CLEAR** key in LOCAL.

DATA CLEAR [ENT]

**2** Press the **ENTER** key.

- The ACTIVE lamp goes out.
- The received data is erased then it returns to the local mode.

\*\* DATA CLEAR \*\*

## Behavior after printing has been completed

### Drying Feed

When printing has been completed, the feeding operation is performed to cure the printed surface with the UV lamp.

- Perform the feeding operation until the back edge of printing passes the UV lamp unit.
- When you press the **END** key, the operation is terminated.
- When the machine has been received next data continuously, it will operate after the last data is received.

#### Screen display during drying feeding

Drying  
Please Wait



- When the media remains less, the printed surface cannot be cured enough. Therefore, be careful about the remaining amount of media.

## Manual Drying Feed

When the operation is cancelled before prints are fed under UV lamps, such prints need to be dried/cured by manual feeding.

- 1** Press the **TEST PRINT/CLEANING** key in **LOCAL** three times. TEST FEED  
[ ENT ]
- 2** Press the **ENTER** key. BACKWARD FEED  
: ON
- 3** Press **▲** **▼** to select **ON/OFF**. BACKWARD FEED  
: ON  
 • When setting "ON", rewind the roll media to take up the slack before printing.
- 4** Press the **ENTER** key. UV LAMP  
: OFF
- 5** Press **▲** **▼** to select **ON**. UV LAMP  
: ON
- 6** Press the **ENTER** key. TEST FEED  
START [ ENT ]
- 7** Press the **ENTER** key.  
• After the heater and the UV lamp are ready, start test feeding. \*\* TEST FEED \*\*  
PLEASE : WAIT
- 8** Press the **END** key.  
• The feeding operation is continued until you press the **END** key.  
• Feed it to some extent and check the curing status, and then press the **END** key to terminate.

## Heater cooling down/ heater on standby

When drying feeding has been completed (when it has not been cancelled with the **END** key) and any operation is not performed, the heater temperature is decreased to 40 degrees C automatically to prevent waviness of the media due to heat of the heater and the machine waits for a while. (If the heater temperature is set to 40 degrees C and less, it does not operate.)

If data has been received, or, if you operate with the key, cooling/ standby status is released.

### Screen display during heater cooling down

HEATER Cooling down

### Screen display during heater on standby

HEATER on Standby

## Cutting a media

For a roll media, two ways are available to cut the media after printing is completed, as follows.

**Important!**

- When a media is cut, be careful that the printed side does not touch the floor or the printed side of other already cut media.
- When using the take-up device, take up a cut medium using the switch of the take-up device.

**1**

Press the **CUT** key.

MEDIA CUT [ENT]

**2**

Press the **ENTER** key.

MEDIA CUT  
CUT POSITION [▲▼]

**3**

Press **▲▼** to specify the cutting position.

CUT POSITION  
0.0 ----

**4**

Press the **ENTER** key.

\*\* CUTTING \*\*  
PLEASE WAIT

- The media is cut.
- When the cutting has been completed, the current mode returns to LOCAL.



- During the origin setting with the jog keys, you can also perform media cutting by pressing the **CUT** key. (☞ P.2-13)



# Chapter 3

## Extended Functions



### This chapter

describes the operation procedures for using the machine more conveniently and each setting procedure.

List of Functions .....	3-2	tridge.....	3-17
Setting Logical Seek .....	3-3	Setting Time.....	3-22
Setting Drying Time .....	3-5	Setting Units .....	3-23
Setting Margins .....	3-6	Setting a KEY BUZZER.....	3-24
Perform setting to reduce stripes between passes .....	3-7	Set the network.....	3-25
Setting nozzle face cleaning time .....	3-8	Setting event mail function.....	3-27
Setting Auto Cleaning .....	3-9	Setting a LANGUAGE.....	3-36
Other Settings .....	3-10	Initializing the Settings .....	3-37
Machine Settings .....	3-11	Confirming Machine Information .....	3-38
Setting a AUTO Power-off.....	3-13	Displaying the Information .....	3-38
Setting the Display of Media Residual .....	3-14	Check such as the machine version information .....	3-40
Adjusting the Remaining Amount in the Ink Car-		Displaying the Information of this machine .	3-41

# List of Functions

This section describes the overview of each function to be set and set values that can be registered in user types.



• **About default “HOST” function**

You can operate this by the setting value specified in RIP software.

When you set to other than “HOST”, it operates by that setting value, not by the instruction from RIP software.

Depending on RIP software, there are some functions that cannot be instructed by software. In such a case, it operates by the setting value of “When no instruction from RIP exists”.

- For the specifying method with the RIP software, refer to the operation manual of the RIP software.

Function name		Set value	Default	When no instruction from RIP exists *1	Outline
FEED COMP. (☞ P.2-20)		-9999 ~ 0 ~ 9999	0	————	Used to print a pattern for correcting a media-feeding rate and correct it.
DROP. POS CORRECT		-40.0 ~ 0 ~ 40.0	0	————	Used to adjust the dot position in go and return printing.
HEATER (☞ P.2-14)	Pre-Heater	OFF/ 20 ~ 70°C (OFF/ 68 ~ 122°F)	OFF	————	Sets heater conditions.
	Print Heater	OFF/ 20 ~ 70°C (OFF/ 68 ~ 122°F)	OFF	————	
	Post Heater	OFF/ 20 ~ 70°C (OFF/ 68 ~ 122°F)	OFF	————	
LOGICAL SEEK(☞ P.3-3)		HOST	HOST	OFF (MACHINE WIDTH)	Sets the scan movable area during printing.
		ON			
		OFF   MACHINE WIDTH / MEDIA WIDTH/ MANUAL WIDTH			
INK LAYERS (☞ P.3-10)		HOST / 1 ~ 9	HOST	1	Sets the number of layers in which ink is to be applied.
DRYING TIME (☞ P.3-3)	SCAN	HOST / 0.0 ~ 9.9 sec	HOST	0.0 sec	Sets the time to wait for ink drying.
	PRINT END	HOST / 0 ~ 999 sec	HOST	0 sec	
MARGIN (☞ P.3-6)	LEFT	HOST / -10 ~ 85mm (1mm unit)	HOST	0 mm	Sets a non-printing area along the right and left edges of the media.
	RIGHT	HOST / -10 ~ 85mm (1mm unit)	HOST	0 mm	
VACUUM (☞ P.3-10)		HOST / STANDARD / STRONG	HOST	STANDARD	Sets the absorbability of the media.
FEED SPEED (☞ P.3-10)		HOST / 10 ~ 200%	HOST	100%	Changes the media feeding speed in printing.*2
MAPS (☞ P.3-7)	OFF / ON		OFF	————	Perform setting to reduce stripes between passes.
	PRINT SPEED ADJUST	-50 ~ +50%	0%	————	
AUTO CLEANING (☞ P.3-8)	INTERVAL	OFF / 1 ~ 1000 page	OFF	————	Sets the automatic cleaning operation of the head at the start of printing.
	TYPE	SOFT / NORMAL / HARD	SOFT	————	
INTERVAL WIPING (☞ P.3-9)		3 ~ 255 min, OFF	30min	————	Sets the wiping operation during printing.

\*1. This is the setting value to be used for printing when setting value is not specified at the RIP software (host) side, or, you give priority to the setting value at the machine side, even if you set “Host” to the type registration of this machine.

\*2. When you set this to “100%” or more, required time for completion of printing will be shortened. However, enough drying time cannot be ensured and it may affect the image quality.

# Setting Logical Seek

The motion of Head varies depending on the set of Logical-seek.

**Important!**

- You cannot specify the logical seek at the RasterLinkPro side. When you set this machine to "Host", printing will be performed in "LOGICAL SEEK=OFF" status.
- When you set this to "ON" or "HOST"**  
Required time for completion of printing will be shortened. However, enough drying time cannot be ensured and it may affect the image quality.

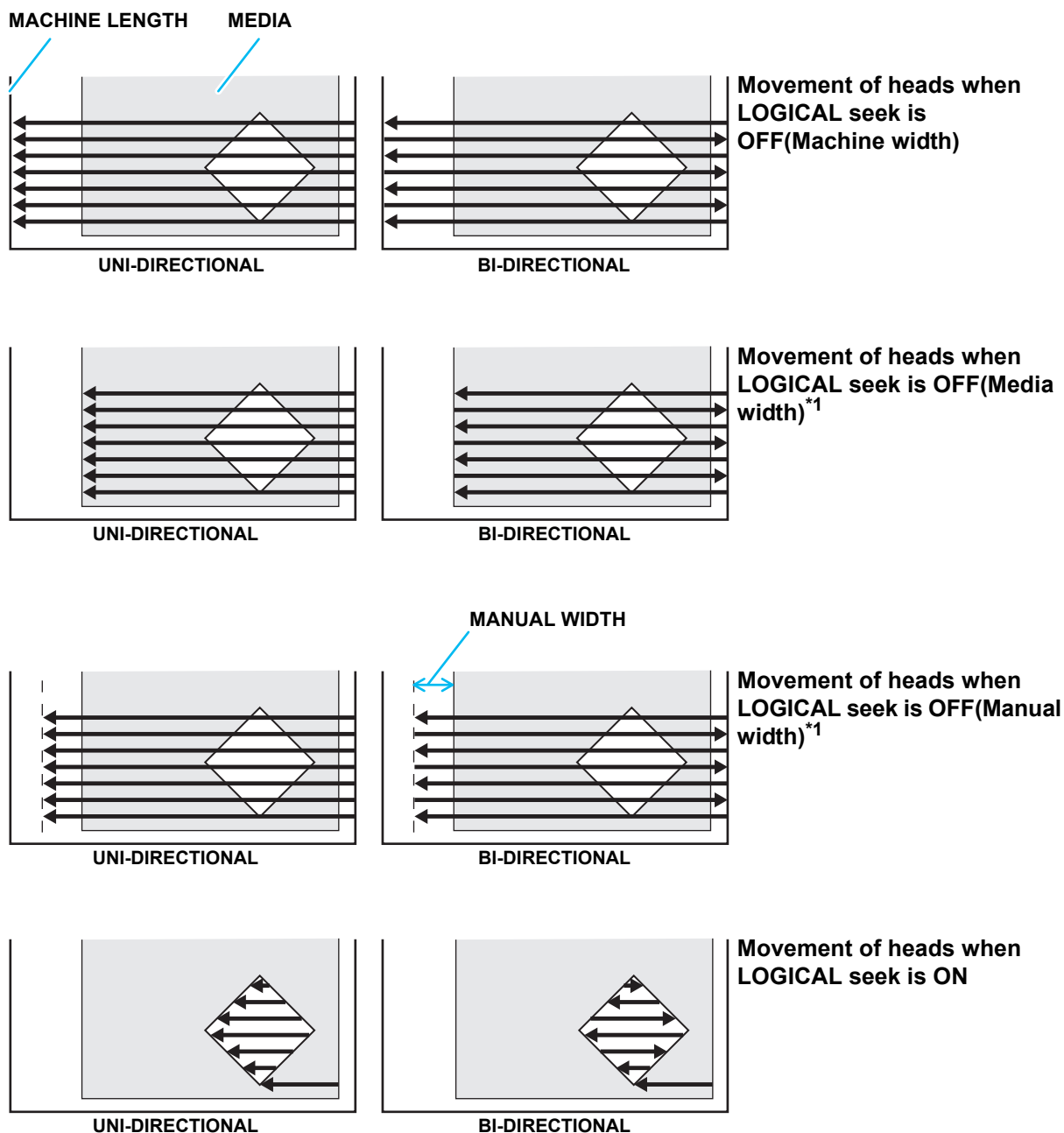

Convenient use

\*1. Supported from the firmware ver.2.60

1	Press the <b>FUNCTION</b> key in LOCAL.	FUNCTION SETUP [ENT]
2	Press the <b>ENTER</b> key.	SETUP FEED COMP. [ENT]
3	Press <b>▲▼</b> to select [LOGICAL SEEK].	SETUP LOGICAL SEEK [ENT]
4	Press the <b>ENTER</b> key.	LOGICAL SEEK :HOST
5	Press <b>▲▼</b> to select a set value. • Set value : HOST / ON / OFF	LOGICAL SEEK :OFF
6	Press <b>▲▼</b> to select a motion of head.*1 • Set value : MACHINE WIDTH / MEDIA WIDTH / MANUAL WIDTH	LOGICAL SEEK OFF :MACHINE WIDTH
7	Press the <b>ENTER</b> key.   • When "MANUAL WIDTH" is selected in step 6, set the width of the head movements.*1 (1) Press <b>▲▼</b> , and set the width within 0mm to the width of platen. (2) Press the <b>ENTER</b> key.	SETUP LOGICAL SEEK [ENT]  LEFT (MEDIA WIDTH+) = 0mm
8	Press the <b>END</b> key several times to end the setting.	

\*1.Settings of logical seek "off" is supported from the firmware ver.2.60



# Setting Drying Time

In the drying time setting, the following items for ink drying time are set.

- **SCAN** : Ink drying time for each scanning is set. (During bidirectional printing, the machine stops for a certain period of time specified for each of the outward and return scanning.)

**Important!**

- When you give priority to the setting at the RasterLinkPro side, make the setting value "Host".
- "SCAN" set in this machine is displayed as "Pause Time per Scan" in the RasterLinkPro.

<b>1</b>	Press the <b>FUNCTION</b> key in LOCAL.	FUNCTION SETUP [ENT]
<b>2</b>	Press the <b>ENTER</b> key.	SETUP FEED COMP. [ENT]
<b>3</b>	Press <b>▲</b> <b>▼</b> to select [DRYING TIME].	SETUP DRYING TIME [ENT]
<b>4</b>	Press the <b>ENTER</b> key.	SCAN = HOST
<b>5</b>	Press <b>▲</b> <b>▼</b> to set drying time for scanning. <ul style="list-style-type: none"><li>• To enable the drying time specified in your RIP, select "Host".</li><li>• <b>Scanning setting value</b> : Host or 0.0 sec. to 99 sec.</li></ul>	SCAN = HOST
<b>6</b>	Press the <b>ENTER</b> key.	SETUP DRYING TIME [ENT]
<b>7</b>	Press the <b>END</b> key several times to end the setting.	

# Setting Margins

Set a non-printing area along the right and left edges of the media.  
The offset value against the standard margin 15mm is set hereupon.

**Important!**

- When you give priority to the setting at the RIP software side, make the setting value "Host".
- You cannot specify the margins at the attached RIP software (RasterLinkPro). When you use the RasterLinkPro, if you set this machine to "Host", printing will be performed in "Margins for right and left off set value= 0 mm" status.

<b>1</b>	Press the <b>FUNCTION</b> key in LOCAL.	FUNCTION SETUP [ENT]
<b>2</b>	Press the <b>ENTER</b> key.	SETUP FEED COMP. [ENT]
<b>3</b>	Press <b>▲▼</b> to select [MARGIN].	SETUP MARGIN [ENT]
<b>4</b>	Press the <b>ENTER</b> key.	LEFT = HOST
<b>5</b>	Press <b>▲▼</b> to set the left margins. Set Value :HOST or -10 to 85mm (in 1mm increment)	LEFT = 0mm
<b>6</b>	Press the <b>ENTER</b> key.	RIGHT = HOST
<b>7</b>	Press <b>▲▼</b> to set the right margins. Set Value :HOST or -10 to 85mm (in 1mm increment)	RIGHT = 0mm
<b>8</b>	Press the <b>ENTER</b> key.	SETUP MARGIN [ENT]
<b>9</b>	Press the <b>END</b> key several times to end the setting.	



- Pay attention to that printing may start on the media press if a right and left margin is set to 5 mm or less when the media press is used in printing.

# Perform setting to reduce stripes between passes

In case that feeding stripes cannot be resolved even though media correction (☞ P.2-20) is performed, make "MAPS (Mimaki Advanced Pass System) valid. Feeding stripes become less visible by distributing the pass boundary. (Supported from the firmware ver.2.10)



- Depending on the printing condition, the effect cannot be recognized.

<b>1</b>	Press the <b>FUNCTION</b> key in LOCAL.	FUNCTION SETUP [ ENT ]
<b>2</b>	Press the <b>ENTER</b> key.	SETUP FEED COMP . [ ENT ]
<b>3</b>	Press <b>▲</b> <b>▼</b> to select [MAPS].	SETUP MAPS [ ENT ]
<b>4</b>	Press the <b>ENTER</b> key.	MAPS : OFF
<b>5</b>	Press <b>▲</b> <b>▼</b> to set ON/OFF. • Set Value : OFF, ON	MAPS : ON
<b>6</b>	Press the <b>ENTER</b> key. • When you select OFF, proceed to the Step 9.	PRINT SPEED ADJUST = 0%
<b>7</b>	Press <b>▲</b> <b>▼</b> to change print speed. • Set Value : -50 ~ +50%	PRINT SPEED ADJUST = 10%
	<b>Important!</b> • When you speed up, nozzle recovery effect cannot work in some cases. Use it after checking.	
<b>8</b>	Press the <b>ENTER</b> key.	SETUP MAPS [ ENT ]
<b>9</b>	Press the <b>END</b> key several times to end the setting.	

# Setting Auto Cleaning

You can set items so that the head cleaning is automatically performed when printing has been completed for the set interval.

When printing has been completed, the machine counts the print count printed after the previous head cleaning and performs the cleaning automatically if necessary.

The machine can perform a stable printing operation with its heads always kept clean.

The first cleaning is performed immediately before the first printing after the machine is started. Then subsequent cleaning is performed every printing on the specified count of print.

- 1** Press the **FUNCTION** key in LOCAL. FUNCTION  
SETUP [ENT]
- 2** Press the **ENTER** key. SETUP  
FEED COMP. [ENT]
- 3** Press **▲▼** to select [AUTO CLEANING]. SETUP  
AUTO CLEANING [ENT]
- 4** Press the **ENTER** key. INTERVAL  
= OFF
- 5** Press **▲▼** to set a cleaning interval.  
• Set value : OFF / 1 to 1000page  
• When selecting OFF, proceed to Step 8. INTERVAL  
= 1 page
- 6** Press the **ENTER** key. TYPE  
: SOFT
- 7** Press **▲▼** to set a cleaning type.  
• Set value : NORMAL / SOFT / HARD TYPE  
: NORMAL
- 8** Press the **ENTER** key.
- 9** Press the **END** key several times to end the setting.

**Important!**

- Depending on the state of the heads, etc., the image quality deterioration may not be improved even with this function performed. In this case, contact our service office or the distributor in your region.

# Setting nozzle face cleaning time

When the set time has passed, nozzle face of the head is cleaned automatically to remove ink droplets on the nozzle face.

In case that deflection, nozzle missing, or symptom which ink droplets fall down occurred, make the interval between each operation shorter.

<b>1</b>	Press the <b>FUNCTION</b> key in LOCAL.	FUNCTION SETUP [ENT]
<b>2</b>	Press the <b>ENTER</b> key.	SETUP FEED COMP. [ENT]
<b>3</b>	Press <b>▲</b> <b>▼</b> to select [INTERVAL WIPING].	SETUP INTERVAL WIPING [ENT]
<b>4</b>	Press the <b>ENTER</b> key.	INTERVAL WIPING = 30min
<b>5</b>	Press <b>▲</b> <b>▼</b> to set intervals. • Set Value : 3 to 255 min, OFF • When [OFF] is set, periodical wiping is not executed.	INTERVAL WIPING = 30min
<b>6</b>	Press the <b>ENTER</b> key.	SETUP INTERVAL WIPING [ENT]
<b>7</b>	Press the <b>END</b> key several times to end the setting.	

# Other Settings

Change the settings according to the types of use.

1

Press the **FUNCTION** key in LOCAL.

FUNCTION  
SETUP [ENT]

2

Press the **ENTER** key.

SETUP  
FEED COMP. [ENT]

3

Press **▲** **▼** to select an item for setting.

- Select it, referring to P.3-2 "List of Functions".

4

Press the **ENTER** key.

5

Press **▲** **▼** to select the setting value.

- Select it, referring to P.3-2 "List of Functions".

6

Press the **ENTER** key.

7

Press the **END** key several times to end the setting.

**Important!**

- The set value is retained even when the power is turned "OFF".

# Machine Settings

Common settings are functions for using this machine easily.  
The following items can be set in Machine settings.

Item	Set value	Default	Meaning	
AUTO Power-off	NONE/ 10 ~ 600min	30min	When no operation has been performed for the set time, the power supply is automatically turned "OFF".	
M E D I A REMAIN (☞ P.3-14)	ON	0.0 to 500.0m	You can control the remaining amount of media.	
	OFF			
INK LEVEL SET (☞ P.5-7)	Cart. Weight	1 to 8		
	Case Weight	1 to 8		
	Alarm Display	ON / OFF	OFF	
TIME	+4h ~ -20h	Japan time	Time difference is corrected.	
UNIT	TEMP.	°C (Centigrade) /°F (Fahrenheit)	°C	A unit for displaying temperature is set.
	LENGTH	mm / inch	mm	A unit for displaying length and area is set.
KEY BUZZER	OFF / ON	ON	A buzzer sound when keys are pressed is set.	
NETWORK (☞ P.3-25)	Set the network.			
	Check IP Addr.	The IP address currently used by this machine is displayed.		
	Check MAC Addr.	The IP address currently used by this machine is displayed.		
	DHCP	ON / OFF		When it is ON, the IP address given by the DHCP server is used.
	AutoIP	ON / OFF		When it is ON, the IP address is determined by the AutoIP protocol. However, DHCP is ON, DHCP has priority.
	IP Address *1	Set the IP address used by this machine.		
	Default Gateway *1	Set the default gateway used by this machine.		
	DNS Address *1	Set the DNS server address used by this machine.		
	SubNet Mask *1	Set the digit number of the subnet mask used by this machine.		

Item		Set value		Default	Meaning	
EVENT MAIL (☞ P.3-27)	Mail Delivery	ON / OFF		OFF	Set whether you send/ do not send the e-mail when the set event occurs.	
	Select Event	Print Start Event	ON / OFF	OFF	Set whether you send/ do not send the e-mail at the start of printing.	
		Print End Event	ON / OFF	OFF	Set whether you send/ do not send the e-mail at the end of printing.	
		Error Event	ON / OFF	OFF	Set whether you send/ do not send the e-mail when a error occurs.	
		Warning Event	ON / OFF	OFF	Set whether you send/ do not send the e-mail when a warning occurs.	
		Other Event	ON / OFF	OFF	Set whether you send/ do not send the e-mail when an event other than the above occurs.	
	Mail Address	Set the e-mail address to which you send the event mail.		Alphanumeric characters and symbols (within 96 characters)		
	Message Subject	Set the characters to write in the subject of the event mail.		Alphanumeric characters and symbols (within 8 characters)		
	Server Setup	SMTP Address		Set the SMTP server.		
		SMTP Port No.		Set the SMTP port number.		
		SENDER ADDRESS		Set the e-mail address to be used as the sender mail address.		
		Authenticati on	POP before SMTP	Set the SMTP server authentication method (SMTP authentication).		
			SMTP Authenticati on			
			OFF			
		User Name *2		Set the user name used for the authentication.		
Pass Word *2		Set the password used for the authentication.				
POP3 Address *3		Set the POP server.				
APOP *3		Set ON/ OFF of APOP.				
Transmit Test	Send the test e-mail.					
LANGUAGE	English ニホンゴ Deutsch Français Español Italiano Português		English	Displayed language is changed.		
RESET(☞ P.3-37)	—————		—————	All setting values are returned to the status default.		

\*1. Settable when both of DHCP and AutoIP are [OFF]

\*2. Settable only when Auth. is not OFF

\*3. Settable only when Auth. is POP before SMTP



## Setting a AUTO Power-off

When no operation has been performed for the set time, the power supply is automatically turned "OFF".

**1** Press the **FUNCTION** key in LOCAL.

```
FUNCTION
SETUP [ENT]
```

**2** Press **▲** **▼** to select [MACHINE SETUP].

```
FUNCTION
MACHINE SETUP [ENT]
```

**3** Press the **ENTER** key twice.

```
AUTO Power - off
= 30min
```

**4** Press **▲** **▼** to set time to turn OFF the power supply.

```
AUTO Power - off
= 60min
```

• Set Value : none, 10 to 600min

**5** Press the **ENTER** key.

```
MACHINE SETUP
AUTO Power - off [ENT]
```

**6** Press the **END** key several times to end the setting.

**Important!**

- If the machine received data from the PC in the auto-power-off status, the power supply is turned ON, however, printing operation is not started automatically.

## Setting the Display of Media Residual

Whether the screen displays the remaining amount of a media is set.

<b>When the media remaining amount display is turned to "ON"</b>	the remaining amount of a media is displayed in Remote.
<b>When the media remaining amount display is turned to "OFF"</b>	the remaining amount of a media is not displayed in the Remote.



- The amount of a media that has been fed by the printing and jog keys is reflected in the remaining amount of a media.
- The length of a media (initial value of the remaining amount) is entered when a roll media is detected. (P.2-12)
- The setting configured here does not become effective unless media detection is performed after the setting has been complete.

**1**

Press the **FUNCTION** key in LOCAL.

FUNCTION  
SETUP [ENT]

**2**

Press **▲▼** to select [MACHINE SETUP].

FUNCTION  
MACHINE SETUP [ENT]

**3**

Press the **ENTER** key.

MACHINE SETUP  
AUTO Power-off [ENT]

**4**

Press **▲▼** to select [MEDIA REMAIN].

MACHINE SETUP  
MEDIA REMAIN [ENT]

**5**

Press the **ENTER** key.

MEDIA REMAIN  
: OFF

**6**

Press **▲▼** to select ON/OFF.

MEDIA REMAIN  
: ON

**7**

Press the **ENTER** key.

- If you selected "A" in step 6: proceed to step 8 and input the remaining amount of media.
- If you selected "A" in step 6: proceed to step 9.



**The following procedure depends on the firmware version of your device.**

- If you are using A or earlier,
  - you cannot input the remaining amount of media by selecting A in step 6. Proceed to step 9.
- If you are using A or later,
  - proceed to step 8 if you selected "A" in step 6, and input the remaining amount of media.

**8**

Press   to input the media remain.

• Set Value : 0.0 to 500.0 min

INPUT MEDIA LENGTH
= 50.0m

**9**

Press the  key several times to end the setting.

## Printing the Remaining Amount of a Media

The present remaining amount of a media can be printed.



- Set "Remaining amount of a media to display" to "ON".
- When you replace the media you use now with another, it is recommended that you print the remaining amount of the media on it. With the remaining amount of a media having been printed beforehand, when you use the replaced media again, you can enter an accurate value in the screen for entering the remaining amount of a media (P.2-12) that appears after media detection.

# 1









In LOCAL, Press    .

- LOCAL changes to the origin setting mode.

```
ORIGIN SETUP
0.0    - - - -
```

# 2





    Press to set a light point of the LED pointer to the changing position.

- Move the carriage and media with     and set the origin.
- When you do not change the origin, do not press     and proceed to Step 3.
- When you press the  key here, the origin is changed, and the screen returns to LOCAL.

```
ORIGIN  SETUP
0.0    0.0
Origin  Origin
(Length) (Width)
```

# 3

Press the  key.

- When you press     , the screen returns to Step 2.
- When you press the  key, the screen returns to LOCAL.

```
MEDIA REMAIN PRINT
<ENT>
```

# 4

Press the  key.

- The remaining amount of a media starts to be printed.
- When the printing has been completed, the screen returns to LOCAL.

**Important!**

- When the remaining amount of a media has been printed with the origin changed, the origin set here is effective even when subsequent data are printed.

## Adjusting the Remaining Amount in the Ink Cartridge

The remaining amount of ink in the ink cartridge can be adjusted. (available for the firmware Ver.3.40 and later)



- You need a scale (which can weigh up to 1200g in 1g) to adjust the remaining amount of ink. Please prepare your scale.

### 1 Setting the INK REMAIN

This setting allows you to adjust the remaining amount of ink or use the eco case. For details, refer to P.3-17.

### 2 Registering the case weight

When using the eco case, you need to register the case weight in order to be able to adjust the remaining amount of ink inside the ink cartridge accurately. Refer to P.3-19 and register the weight.

### 3 Registering the cartridge weight

By weighing the whole ink cartridge including the IC chip and the ink pack, you can adjust the remaining amount of ink inside the cartridge. Follow the instructions on P.3-20 and register the

## Setting the INK REMAIN

By setting INK REMAIN to "ON", you enable the following functions.

- You can detect the remaining amount of ink inside the ink cartridge and adjust the cartridge weight.
- When the ink inside the ink cartridge is low, a message is displayed reminding you to weigh the cartridge. (☞ P.5-7)



- If there are any slots with unregistered case weight when using the eco case, register the case weight.

### 1 Press the key in LOCAL.

FUNCTION  
SETUP [ENT]

### 2 Press to select [MACHINE SETUP].

FUNCTION  
MACHINE SETUP [ENT]

### 3 Press the **ENTER** key.

**4** Press   to select [INK REMAIN].

MACHINE SETUP  
INK REMAIN [ENT]

**5** Press the  key.

**6** Press   to select [SET UP].

INK REMAIN  
: SET UP



**7** Press the  key.

**8** Press   to select ON/OFF.

INK REMAIN  
: ON

**9** Press the  key.

- If you select “ON” in step 8 : proceed to step 10.
- If you select “OFF” in step 8 : proceed to step 14.

**10** Press   to select use eco case.

- If you select “YES” : The slots with unregistered case weight are displayed. Proceed to step 11.
- If you select “NO” : proceed to step 14.

Use Eco Case?  
NO< >YES

**11** Use a scale to weigh the eco case in the slot shown on the display.

- Do not attach the IC chip and the ink pack when weighing.

**12** Press   to enter the weight checked at the Step 11 and press the  key.

Cart.Slot1  
Case Weight = 326g

**13** Repeat steps 11 and 12 until the case weight is registered on all the slots shown on the display.

**14** Press the  key several times to end the setting.

## Registering the case weight

When using the eco case, you need to register the case weight. Follow the steps below to register the case weight.

**Important!**

- If you replace the eco cartridge because the eco case is damaged, you need to register the case weight again in order to set the remaining amount in the ink cartridge correctly.
- You can only register the case weight when SET UP (☞ P.3-17) in INK REMAIN is set to "ON", and the eco case use is enabled.

### 1 Weigh the case of an empty cartridge on the scale.

- Do not attach the IC chip and the ink pack when weighing.

### 2 Press the **FUNCTION** key in LOCAL.

```
FUNCTION
SETUP [ENT]
```

### 3 Press **▲ ▼** to select **[MACHINE SETUP]**.

```
FUNCTION
MACHINE SETUP [ENT]
```

### 4 Press the **ENTER** key.

### 5 Press **▲ ▼** to select **[INK REMAIN]**.

```
MACHINE SETUP
INK REMAIN [ENT]
```

### 6 Press the **ENTER** key.

### 7 Press **▲ ▼** to select **[Case Weight]**.

```
INK REMAIN
:Case Weight
```

### 8 Press the **ENTER** key.

### 9 Press **▲ ▼** to choose the cartridge for which you wish to register the weight.

```
Case Weight
Cart.Slot : 1
```

### 10 Press the **ENTER** key.

**11** Press   to enter the weight checked at the Step 1.

Cart.Slot1  
Case Weight = 326g

**12** Press the  key.

**13** Press the  key several times to end the setting.

## Registering the cartridge weight

Calculate the remaining amount of ink from the ink cartridge weight including the IC chip and ink pack, and adjust the amount.

**Important!** • You can only register the case weight when SET UP in INK REMAIN is set to "ON". (☞ P.3-17)

**1** Weigh the ink cartridge on the scale.  
• Attach the IC chip and the ink pack when weighing.

**2** Press the  key in LOCAL.

FUNCTION  
SETUP [ENT]

**3** Press   to select [MACHINE SETUP].

FUNCTION  
MACHINE SETUP [ENT]

**4** Press the  key.

**5** Press   to select [INK REMAIN].

MACHINE SETUP  
INK REMAIN [ENT]

**6** Press the  key.

**7** Press   to select [Cart. Weigth].

INK REMAIN  
:Cart. Weight

**8** Press the  key.



9

Press to choose the cartridge (1 to 8) for which you wish to register the weight.

```
InkLevelSet
Cart.Slot : 1
```

10

Press the **ENTER** key.

11

Press **▲** **▼** to enter the weight checked at the Step 1.

```
Cart.Slot1
INK REMAIN = 640g
```

12

Check the weight and press the **ENTER** key.

```
Cart.Slot1
INK REMAIN = 640g
```

13



Press the **END** key several times to end the setting.



- When total entered weight of ink exceeds certain quantity, "Save Failure" error occurs again and entry becomes invalid.

## Setting Time

You can set time of your country (time difference).

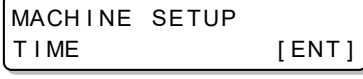
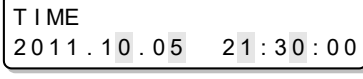
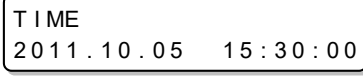
- 1** Press the **FUNCTION** key in LOCAL. 
- 2** Press **▲** **▼** to select **[MACHINE SETUP]**. 
- 3** Press the **ENTER** key. 
- 4** Press **▲** **▼** to select **[TIME]**. 
- 5** Press the **ENTER** key. 
- 6** Press **▲** **▼** **◀** **▶** to enter time.  
Year/Month/Day/Time selecting: by the **◀** **▶** keys.  
Year/Month/Day/Time inputting: by the **▲** **▼** keys.
- 7** Press the **ENTER** key.  
• The entered date is displayed. 
- 8** Press the **END** key several times to end the setting.



• -20 hours to +4 hours can be set.

## Setting Units

Units used by this machine are set.

- 1** Press the key **FUNCTION** in LOCAL.

FUNCTION  
SETUP [ENT]
- 2** Press **▲** **▼** to select [MACHINE SETUP].

FUNCTION  
MACHINE SETUP [ENT]
- 3** Press the **ENTER** key.

MACHINE SETUP  
AUTO Power-off [ENT]
- 4** Press **▲** **▼** to select [UNIT].

MACHINE SETUP  
UNIT [ENT]
- 5** Press the **ENTER** key.

TEMP  
: °C
- 6** Press **▲** **▼** to select a unit of the temperature.  
• Set value : °C / °F
- 7** Press the **ENTER** key.

LENGTH  
: mm
- 8** Press **▲** **▼** to select a unit of the length.  
• Set value : mm / inch
- 9** Press the **ENTER** key.

MACHINE SETUP  
UNIT [ENT]
- 10** Press the **END** key several times to end the setting.

## Setting a KEY BUZZER

You can turn off the buzzer sound when pressing the key.

- 1** Press the **FUNCTION** key in LOCAL. FUNCTION  
SETUP <ENT>
- 2** Press **▲▼** to select **[MACHINE SETUP]**. FUNCTION  
MACHINE SETUP [ENT]
- 3** Press the **ENTER** key. MACHINE SETUP  
AUTO Power-off [ENT]
- 4** Press **▲▼** to select **[KEY BUZZER]**. MACHINE SETUP  
KEY BUZZER [ENT]
- 5** Press the **ENTER** key. KEY BUZZER  
: ON
- 6** Press **▲▼** to select **ON/OFF**. KEY BUZZER  
: OFF
- 7** Press the **ENTER** key. MACHINE SETUP  
KEY BUZZER [ENT]
- 8** Press the **END** key several times to end the setting.





- When the key buzzer is set to "OFF", the buzzer sound for errors, warnings, operation completion, etc. cannot be shut off.

## Set the network

You can also perform network setting with "Network Configurator", the tool to perform network setting of Mimaki's product. To download the Network Configurator, check "Driver / Utility" on the download page at Mimaki Engineering (<https://mimaki.com/download/>).

<b>1</b>	Press the <b>FUNCTION</b> key in LOCAL.	FUNCTION SETUP [ENT]
<b>2</b>	Press <b>▲</b> <b>▼</b> to select <b>[MACHINE SETUP]</b> .	FUNCTION MACHINE SETUP [ENT]
<b>3</b>	Press the <b>ENTER</b> key.	MACHINE SETUP AUTO Power-off [ENT]
<b>4</b>	Press <b>▲</b> <b>▼</b> to select <b>[NETWORK]</b> .	MACHINE SETUP NETWORK [ENT]
<b>5</b>	Press the <b>ENTER</b> key.	NETWORK Check IP Addr. [ENT]
<b>6</b>	Press the <b>ENTER</b> key. <ul style="list-style-type: none"> <li>The IP address currently used by this machine is displayed.</li> <li>After connecting with the network, it takes time until the IP address is determined. If the IP address has not been determined, "0.0.0.0" is displayed.</li> </ul> 	Check IP Address 10.16.168.235
<b>7</b>	Press the <b>ENTER</b> key.	NETWORK Check IP Addr. [ENT]
<b>8</b>	Press <b>▲</b> <b>▼</b> to select <b>[Check MAC Addr.]</b> .	NETWORK Check MAC Addr. [ENT]
<b>9</b>	Press the <b>ENTER</b> key. <ul style="list-style-type: none"> <li>The MAC address currently used by this machine is displayed.</li> </ul>	Check MAC Address 00:0d:1b:00:00:00
<b>10</b>	Press the <b>ENTER</b> key.	NETWORK Check MAC Addr. [ENT]
<b>11</b>	Press <b>▲</b> <b>▼</b> to select <b>[DHCP]</b> .	NETWORK DHCP [ENT]

**12**Press the **ENTER** key.

- Press   to set ON/ OFF.
- When it is ON, the IP address given by the DHCP server is used.

DHCP : ON
--------------



**13**Press the **ENTER** key.

NETWORK DHCP [ ENT ]
-------------------------

**14**Press   to select [AutoIP].

NETWORK AutoIP [ ENT ]
---------------------------

**15**Press the **ENTER** key.

- Press   to set ON/ OFF.
- When it is ON, the IP address is determined by the AutoIP protocol. However, DHCP is ON, DHCP has priority.

AutoIP : ON
----------------

**16**Press the **ENTER** key.

NETWORK AutoIP [ ENT ]
---------------------------

**17**Press   to select the set values.

- Both of DHCP and AutoIP is OFF, you can set IP Address/ Default Gateway/ DNS Address/ Sub Net Mask. For other than above, proceed to the Step 21.

**18**Press the **ENTER** key.**19**Press     to select the set values.**20**Press **ENTER** to confirm the value.**21**Press the **END** key several times for terminating this function.

- To reflect network setting, once turn off the power supply and then turn it on again.

## Setting event mail function

Set the function to send e-mails to the set e-mail address when events such as cutting start/ end and stop due to an error.

### Disclaimer

- The customer is responsible for the communication fee for Internet communication such as e-mail notification.
- The notification by the event mail function may not be delivered due to Internet environment, failure of the device/ the power supply, etc. Mimaki has absolutely no responsibility for any damages or loss resulting from non-delivery or delays.

### Important!

- You can use event mail function by connecting LAN to this machine. Please prepare for LAN cable connection beforehand.
- Not compatible with SSL communication.

## Enable the event mail function

<b>1</b>	Press the <b>FUNCTION</b> key in LOCAL.	FUNCTION SETUP [ENT]
<b>2</b>	Press <b>▲</b> <b>▼</b> to select [MACHINE SETUP].	FUNCTION MACHINE SETUP [ENT]
<b>3</b>	Press the <b>ENTER</b> key.	MACHINE SETUP AUTO Power-off [ENT]
<b>4</b>	Press <b>▲</b> <b>▼</b> to select [EVENT MAIL].	MACHINE SETUP EVENT MAIL [ENT]
<b>5</b>	Press the <b>ENTER</b> key.	EVENT MAIL Mail Delivery [ENT]
<b>6</b>	Press the <b>ENTER</b> key.	Mail Delivery :OFF
<b>7</b>	Press <b>▲</b> <b>▼</b> to select "ON".	Mail Delivery :ON
<b>8</b>	Press the <b>ENTER</b> key.	EVENT MAIL Mail Delivery [ENT]
<b>9</b>	Press the <b>END</b> key several times for terminating this function.	

## Set the event to send an event mail

<b>1</b>	Press the <b>FUNCTION</b> key in LOCAL.	FUNCTION SETUP [ENT]
<b>2</b>	Press <b>▲</b> <b>▼</b> to select [MACHINE SETUP].	FUNCTION MACHINE SETUP [ENT]
<b>3</b>	Press the <b>ENTER</b> key.	MACHINE SETUP AUTO Power-off [ENT]
<b>4</b>	Press <b>▲</b> <b>▼</b> to select [EVENT MAIL].	MACHINE SETUP EVENT MAIL [ENT]
<b>5</b>	Press the <b>ENTER</b> key.	EVENT MAIL Mail Delivery [ENT]
<b>6</b>	Press the jog key <b>▲</b> or <b>▼</b> to select [Select Event] .	EVENT MAIL Select Event [ENT]
<b>7</b>	Press the <b>ENTER</b> key. • Set whether you send/ do not send the e-mail at the start of printing. • Press <b>▲</b> <b>▼</b> to set ON/ OFF.	Print Start Event :OFF
<b>8</b>	Press the <b>ENTER</b> key. • Set whether you send/ do not send the e-mail at the end of printing. • Press <b>▲</b> <b>▼</b> to set ON/ OFF.	Print End Event :OFF
<b>9</b>	Press the <b>ENTER</b> key. • Set whether you send/ do not send the e-mail when the printing operation stops because an error occurs. • Press <b>▲</b> <b>▼</b> to set ON/ OFF.	Error Evenn :OFF
<b>10</b>	Press the <b>ENTER</b> key. • Set whether you send/ do not send the e-mail when a warning occurs during printing. • Press <b>▲</b> <b>▼</b> to set ON/ OFF.	Warning Event :OFF
<b>11</b>	Press the <b>ENTER</b> key. • Set whether you send/ do not send the e-mail when an event other than the above occurs. • Press <b>▲</b> <b>▼</b> to set ON/ OFF.	Other Event :OFF
<b>12</b>	Press the <b>ENTER</b> key.	EVENT MAIL Select Event [ENT]



**13** Press the **END** key several times for terminating this function.

### Set the e-mail address

- 1** Press the **FUNCTION** key in LOCAL.

FUNCTION  
SETUP [ENT]
- 2** Press **▲▼** to select [MACHINE SETUP].

FUNCTION  
MACHINE SETUP [ENT]
- 3** Press the **ENTER** key.

MACHINE SETUP  
AUTO Power-off [ENT]
- 4** Press **▲▼** to select [EVENT MAIL].

MACHINE SETUP  
EVENT MAIL [ENT]
- 5** Press the **ENTER** key.

EVENT MAIL  
Mail Delivery [ENT]
- 6** Press **▲▼** to select [Mail Address].

EVENT MAIL  
Mail Address [ENT]
- 7** Press the **ENTER** key.

Mail Address
- 8** Press **▲▼◀▶** to set mail address.

  - Set the e-mail address to which you send the event mail.
  - Set it with alphanumeric characters and symbols within 96 characters.
- 9** Press the **ENTER** key.

EVENT MAIL  
Mail Address [ENT]
- 10** Press the **END** key several times for terminating this function.

## Set the subject

---

- 1** Press the **FUNCTION** key in LOCAL. FUNCTION  
SETUP [ENT]
  - 2** Press **▲▼** to select **[MACHINE SETUP]**. FUNCTION  
MACHINE SETUP [ENT]
  - 3** Press the **ENTER** key. MACHINE SETUP  
AUTO Power-off [ENT]
  - 4** Press **▲▼** to select **[EVENT MAIL]**. MACHINE SETUP  
EVENT MAIL [ENT]
  - 5** Press the **ENTER** key. EVENT MAIL  
Mail Delivery [ENT]
  - 6** Press **▲▼** to select **[Message Subject]** . EVENT MAIL  
Message Subject [ENT]
  - 7** Press the **ENTER** key. Message Subject  
JV400-#1 [ENT]
  - 8** Press **▲▼◀▶** to set subject
    - Set the characters to write in the subject of the event mail.
    - Set it with alphanumeric characters and symbols within 8 characters.
  - 9** Press the **ENTER** key. EVENT MAIL  
Message Subject [ENT]
  - 10** Press the **END** key several times for terminating this function.
-

## Set the server

- 1** Press the **FUNCTION** key in LOCAL.

FUNCTION  
SETUP [ENT]
- 2** Press **▲▼** to select [MACHINE SETUP].

FUNCTION  
MACHINE SETUP [ENT]
- 3** Press the **ENTER** key.

MACHINE SETUP  
AUTO Power-off [ENT]
- 4** Press **▲▼** to select [EVENT MAIL].

MACHINE SETUP  
EVENT MAIL [ENT]
- 5** Press the **ENTER** key.

EVENT MAIL  
Mail Delivery [ENT]
- 6** Press **▲▼** to select [Server Setup] .

EVENT MAIL  
Server Setup [ENT]
- 7** Press the **ENTER** key.

SERVER SETUP  
SMTP Address [ENT]
- 8** Press the **ENTER** key.

  - Press the jog key **▲▼◀▶** to set SMTP server.
  - Input the SMYP server name.

SMTP Address
- 9** Press the **ENTER** key.

SERVER SETUP  
SMTP Address [ENT]
- 10** Press **▲▼** to select [SMTP Port No.] .

SERVER SETUP  
SMTP Port No. [ENT]
- 11** Press the **ENTER** key.

SMTP Port No.  
: 25
- 12** Press **▲▼** to set [SMTP Port No.] .

  - Set the SMTP port number.

SMTP Port No.
- 13** Press the **ENTER** key.

SERVER SETUP  
SMTP Port No. [ENT]

**14** Press the jog key  or  to select [Authentication].

SERVER SETUP  
Authentication [ENT]

**15** Press the  key.

Authentication  
:POP before SMTP



**16** Press   to set authentication method .

- Set the authentication method of the SMTP server.
- When you select [OFF], proceed to the Step 32.

Authentication  
:POP before SMTP





**17** Press the  key.

SERVER SETUP  
Authentication [ENT]

**18** Press   to select [SENDER ADDRESS].

SERVER SETUP  
SENDER ADDRESS [ENT]

**19** Press the  key.

- Press     and set the e-mail address to be used as the sender mail address.
- Set it with alphanumeric characters and symbols within 64 characters.

 • Depending on your server, if you do not set the e-mail address not supporting the account, sending/ receiving e-mails may be unavailable.

SENDER ADDRESS





**20** Press the  key.

SERVER SETUP  
SENDER ADDRESS [ENT]

**21** Press   to select [User Name].

SERVER SETUP  
User Name [ENT]



**22** Press the  key.

- Press     to set the user name to use for the authentication.
- Set it with alphanumeric characters and symbols within 30 characters.

User Name





**23** Press the  key.

SERVER SETUP  
User Name [ENT]

**24** Press   to select [Pass Word] .

SERVER SETUP  
Pass Word [ENT]

**25**Press the **ENTER** key.

- Press     to set the password to use for the authentication.
- Set it with alphanumeric characters and symbols within 15 characters.



- On the password setting screen, you can only check the value that you are currently inputting.

Pass Word  
 \*\*\*\*\*

**26**Press the **ENTER** key.

- When you select [POP before SMTP] in the Step 16, set the items in the Step 27 to 31.

SERVER SETUP  
 Pass Word [ENT]

**27**Press   to select [POP3 Address] .

SERVER SETUP  
 POP3 Address [ENT]

**28**Press the **ENTER** key.

- Press the jog key     to set POP server.
- Input the POP server name.

POP3 Address



**29**Press the **ENTER** key.

SERVER SETUP  
 POP3 Address [ENT]

**30**Press   to select [APOP] .

SERVER SETUP  
 APOP [ENT]

**31**Press the **ENTER** key.

- Press   to set ON/ OFF of APOP.

APOP  
 :ON

**32**Press the **ENTER** key.

SERVER SETUP  
 APOP [ENT]

**33**Press the **END** key several times for terminating this function.

## Send a test e-mail

**1** Press the **FUNCTION** key in LOCAL.

```
FUNCTION
SETUP [ENT]
```

**2** Press **▲▼** to select **[MACHINE SETUP]**.

```
FUNCTION
MACHINE SETUP [ENT]
```

**3** Press the **ENTER** key.

```
MACHINE SETUP
AUTO Power-off [ENT]
```

**4** Press **▲▼** to select **[EVENT MAIL]**.

```
MACHINE SETUP
EVENT MAIL [ENT]
```

**5** Press the **ENTER** key.

```
EVENT MAIL
Mail Delivery [ENT]
```

**6** Press **▲▼** to select **[Transmit Test]**.

```
EVENT MAIL
Transmit Test [ENT]
```

**7** Press the **ENTER** key.

```
Transmit Test
EXECUTE [ENT]
```

**8** Press the **ENTER** key.

```
Transmit Test
Success [ENT]
```

- The sent result is displayed.
- If sending test e-mail has failed, an error code is displayed. Refer to the next page to solve the problem.

```
Transmit Test
Failed: 12345 :ent
```

Error code

**9** Press the **END** key several times for terminating this function.

**Important!**

- The sent result of the test e-mail is the result of e-mail sending process performed by this machine to the e-mail server. It does not indicate that the e-mail was received at the address.
- If the spam e-mail filter etc. has been set in the terminal in which e-mails are received, even if "Sending has been completed" is displayed, the e-mail cannot be received in some cases.
- If sending test e-mail has failed, the error code below is displayed.
- If the error cannot be solved, try again after a while.
- For the server setting etc., contact with the network administrator or the provider.

Error Code	The expected casus	Remedy
10	Network connection error	<ul style="list-style-type: none"> <li>• Check that the machine is connected with the network.</li> <li>• Check that the machine IP address is correct.</li> <li>• Check that the machine is in the environment where DNS is available.</li> </ul>
20	No valid e-mail address.	<ul style="list-style-type: none"> <li>• Enter the correct e-mail address.</li> </ul>
11003 11004	The POP server cannot be found. Or cannot access DNS server.	<ul style="list-style-type: none"> <li>• Check the POP server address.</li> <li>• Check that the machine is in the environment where DNS is available.</li> </ul>
11021	Cannot connect with the POP server.	<ul style="list-style-type: none"> <li>• Check the POP server setting.</li> <li>• Check the firewall setting.</li> </ul>
12010	An error returns from the POP server.	<ul style="list-style-type: none"> <li>• Check the POP server setting.</li> </ul>
13000	The POP authentication has failed.	<ul style="list-style-type: none"> <li>• Check the user name and the password.</li> <li>• Check the APOP setting.</li> <li>• Confirm the authentication method.</li> </ul>
10013 10014	The SMTP server cannot be found. Or cannot access DNS server.	<ul style="list-style-type: none"> <li>• Check the SMTP server address.</li> <li>• Check that the machine is in the environment where DNS is available.</li> </ul>
10021	Cannot connect with the SMTP server.	<ul style="list-style-type: none"> <li>• Check the SMTP server setting.</li> <li>• Check the SMTP port number.</li> <li>• Check the firewall setting.</li> </ul>
10*** 11*** 20*** 21***	An error returns from the SMTP server. Or, there was no response.	<ul style="list-style-type: none"> <li>• Check the SMTP server setting.</li> <li>• Cannot communicate with a server that requires mandatory SSL communication.</li> <li>• Check protocol filter settings.</li> </ul>
12***	It is invalid sender address.	<ul style="list-style-type: none"> <li>• Check that the e-mail address supporting the account entered in the user name/ the password is set in SENDER ADDRESS.</li> </ul>
13***	The e-mail address cannot be found. Or, it is invalid sender address.	<ul style="list-style-type: none"> <li>• Check the e-mail address.</li> <li>• Even if there is a mistake in the e-mail address, this error cannot be detected in some cases.</li> <li>• Check that the e-mail address supporting the account entered in the user name/ the password is set in SENDER ADDRESS.</li> </ul>
22000 22008	SMTP authentication error	<ul style="list-style-type: none"> <li>• Confirm the authentication method.</li> </ul>
23*** 24*** 25***	The SMTP authentication has failed.	<ul style="list-style-type: none"> <li>• Check the user name and the password.</li> </ul>

\*\*\*\* is the error code returned from the e-mail server.

## Setting a LANGUAGE

You can change the displayed language.

- |          |  |                                       |
|----------|--|---------------------------------------|
| <b>1</b> | Press the <b>FUNCTION</b> key in LOCAL.  | FUNCTION<br>SETUP [ENT]               |
| <b>2</b> | Press <b>▲</b> <b>▼</b> to select [MACHINE SETUP].   | FUNCTION<br>MACHINE SETUP [ENT]       |
| <b>3</b> | Press the <b>ENTER</b> key.  | MACHINE SETUP<br>AUTO Power-off [ENT] |
| <b>4</b> | Press <b>▲</b> <b>▼</b> to select [LANGUAGE].  | MACHINE SETUP<br>LANGUAGE [ENT]       |
| <b>5</b> | Press the <b>ENTER</b> key.  | LANGUAGE<br>: English                 |
| <b>6</b> | Press <b>▲</b> <b>▼</b> to select language.<br>• Set Value : ニホンゴ / English / Deutsch / Français / Español /<br>Italiano / Português | LANGUAGE<br>: English                 |
| <b>7</b> | Press the <b>ENTER</b> key.  | MACHINE SETUP<br>LANGUAGE [ENT]       |
| <b>8</b> | Press the <b>END</b> key several times to end the setting.   |                                       |



# Initializing the Settings

You can return the setting of "SETUP", "MAINTENANCE" and "MACHINE SETUP" to the status before shipment.

- 1** Press the **FUNCTION** key in LOCAL. 

FUNCTION SETUP	[ ENT ]
-------------------	---------
- 2** Press **▲** **▼** to select **[MACHINE SETUP]**. 

FUNCTION MACHINE SETUP	[ ENT ]
---------------------------	---------
- 3** Press the **ENTER** key. 

MACHINE SETUP AUTO Power-off	[ ENT ]
---------------------------------	---------
- 4** Press **▲** **▼** to select **[RESET]**. 



MACHINE SETUP RESET	[ ENT ]
------------------------	---------
- 5** Press the **ENTER** key. 

RESET ALL SETTING OK?	[ ENT ]
--------------------------	---------
- 6** Press the **ENTER** key.
  - The already configured settings are initialized.

RESET EXECUTE	[ ENT ]
------------------	---------
- 7** Press the **END** key several times to end the setting.
  - The initial setting screed is displayed. (LANGUAGE/TIME)

# Confirming Machine Information

The information of this machine can be confirmed.  
The following items can be confirmed as machine information.

Item	Description
ERROR HISTORY*1	This displays the history of errors and warnings to date.   When you press  , the date of occurrence (year/month/day/hour/minute) and the error/warning information are displayed alternately in the order of occurrence.
USAGE	WIPING
	WASTE INK TANK
	PRINT LENGTH
	PRINT AREA
	USE TIME
	UV LAMP
VERSION	This displays the firmware version of the machine.
LIST	This allows you to print the settings of the machine.
Ink REPL. Report	This prints ink history of this machine.

\*1. Supported from the firmware ver.2.60

## Displaying the Information

1

Press the  key in LOCAL.

FUNCT I ON  
SETUP [ ENT ]

2

Press   to select [INFORMATION].

FUNCT I ON  
I NFORMAT I ON [ ENT ]

3

Press the  key.

I NFORMAT I ON  
USAGE [ ENT ]

4

Press   to select [USAGE].

**5**

Press the **ENTER** key.

- The wiping Information is displayed.
- Every time when you press the **ENTER** key, the next machine information is displayed sequentially.

**WIPING**

Displays wiping information.

WIPING  
= 0

**WASTE INK TANK**

Displays waste ink tank information.

WASTE INK TANK  
= 0%

**PRINT LENGTH**

Displays printed length up to now.

PRINT LENGTH  
= 0m

**PRINT AREA**

Displays printed area up to now.

PRINT AREA  
= 0m<sup>2</sup>

**USE TIME**

Displays used time information of machine.

USE TIME  
= 0h

**UV LAMP**

Displays used time information of UV lamp.

UV LAMP  
= 0h



- When you reset the used count of the wiper, press the **MAINT.** key while WIPING is displayed. When you press the **ENTER** key, the number of wipings is reset.

WIPING  
RESET? [ENT]

## Check such as the machine version information

- 1** Press the **FUNCTION** key in LOCAL.

FUNCTION  
SETUP [ENT]
- 2** Press **▲▼** to select **[INFORMATION]**.

FUNCTION  
INFORMATION [ENT]
- 3** Press the **ENTER** key.

INFORMATION  
USAGE [ENT]
- 4** Press **▲▼** to select a type of information.

INFORMATION  
VERSION [ENT]
- 5** Press the **ENTER** key.

JV400-160SUV V1.00  
MRL-III V1.80  
-----SUJV-160

  - When [ERROR HISTORY] is selected, the error history Information is displayed.
  - When [VERSION] is selected, the version Information is displayed.
  - When [List] is selected, the setting contents of the machine are printed.
  - When [Ink REPL. Report] is selected, ink history of this machine are printed.

## About Displayed Information

This section describes how to read displayed information.

<p><b>ERROR HISTORY*1</b></p> <p>Displaying the occurrence date</p> <div style="border: 1px solid black; padding: 5px; margin: 5px 0; text-align: center;">             [00000] 2013/07/19 22:13:00         </div> <p style="text-align: center;">◀ ○ ○ ▶</p> <p>Displaying the contents of error</p> <div style="border: 1px solid black; padding: 5px; margin: 5px 0; text-align: center;">             ERROR 12a HDC SPEED         </div>	<p><b>VERSION</b></p> <p>Displaying the version information such as F/W or the like.</p> <div style="border: 1px solid black; padding: 5px; margin: 5px 0; text-align: center;">             JV400-160SUV V1.00 MRL-III V1.80 -----SUJV-160         </div>
--	--

\*1. Supported from the firmware ver.2.60

## Displaying the Information of this machine

**1** Press the **ENTER** key in LOCAL.

```
*** INK      MMCCYYKK
REMAIN      99999999
```

**2** The information is displayed sequentially with the **ENTER** key .

• The information shown on the below appear. 以下は JV400-160SUV をお使いの場合です。

<b>Remaining amount of ink</b>	<b>Error (when ink error occurs)</b>	<b>Warning (when warning occurs)</b>
<pre>*** INK      MMCCYYKK REMAIN      99999999</pre>	<pre>INK IC CAN'T READ MMCCYYKK</pre>	<pre>WARNING Replace a WIPER[MNT]</pre>
<b>Media width</b>	<b>Serial No.</b>	<b>Version</b>
<pre>MEDIA WIDTH =          1000mm</pre>	<pre>SERIAL No. :*****</pre>	<pre>JV400-160SUV  V1.00 MRL-III      V1.80 -----SUJV-160</pre>
<b>RECOVERY NOZZLE</b>		
<pre>RECOVERY NOZZLE CONFIRM DETAILS[MNT]</pre>		

Press the **MAINT.** key and confirm the description

**3** Press the **ENTER** key to return to LOCAL.



Convenient use



# Chapter 4

## Maintenance



### This chapter

describes the items required to use this machine more comfortably, which are the methods for the daily care, the maintenance of the ink unit etc.

Maintenance .....	4-2	When Nozzle Clogging Cannot Be Solved ..	4-23
Precautions for Maintenance .....	4-2	Washing of Head nozzle .....	4-23
About Cleaning Solution .....	4-2	When nozzle missing occurs due to ink mixture or aeration .....	4-26
Maintenance .....	4-2	Alternative nozzles for printing, when nozzles missing can not be improved .....	4-28
Cleaning the Exterior Surfaces .....	4-3	Automatic Maintenance Function .....	4-31
Cleaning the Platen .....	4-3	Setting the Refreshing Intervals .....	4-31
Cleaning of after heater cover and pre heater cover .....	4-4	Setting the Cleaning Intervals .....	4-32
Cleaning the Media Sensor .....	4-4	Setting the Disway wash Intervals .....	4-33
Cleaning the Media Holder .....	4-5	Replacing consumables .....	4-34
Maintaining the Capping station .....	4-6	Replacing the wiper .....	4-34
Cleaning the Wiper and Cap .....	4-6	If a Waste Ink Tank Confirmation Message Appears .....	4-35
Washing the Ink Discharge Passage (DISWAY WASH) .....	4-12	Replacing the waste ink tank before the waste ink tank confirmation message is displayed .....	4-38
When the Machine Is Not Used for a Long Time (CUSTODY WASH) .....	4-13	Replacing the Cutter Blade .....	4-39
NOZZLE PROTECT function .....	4-16	Checking UV ink curing level .....	4-41
Cleaning the Head and the Area around It (every day) .....	4-19		
Replacing method of C absorber kit .....	4-21		

# Maintenance

Maintain the machine regularly or as necessary so that its accuracy will be maintained and it can continue to be used for a long time.

## Precautions for Maintenance

Pay attention to the following items when maintaining this machine.



- Turn off the main power and unplug the power cable before maintenance.

	<ul style="list-style-type: none"> <li>• When using cleaning solution for maintenance, be sure to wear the supplied protective glasses.</li> </ul>
	<ul style="list-style-type: none"> <li>• The ink contains organic solvent. When cleaning the machine, be sure to wear gloves so that no ink will make direct contact with your skin.</li> </ul>
	<ul style="list-style-type: none"> <li>• Never disassemble the machine. Disassembling it can result in electric shock hazards or damage to the machine. Before maintenance, be sure to turn off the power switch and main power switch, and unplug the power cable; otherwise, an unexpected accident may occur.</li> </ul>
	<ul style="list-style-type: none"> <li>• Prevent moisture from entering the machine. Moisture inside the machine can cause electric shock hazards or damage to the machine.</li> </ul>
	<ul style="list-style-type: none"> <li>• To ensure stable ink jetting, it is necessary for the machine to eject a small amount of ink (flushing) regularly when a printing (outputting) operation has not been performed for a long time.</li> <li>• When the machine is not to be used for a long time, turn off only the power switch on the front side, leave the main power switch at the side turned ON (in the position of   ), and leave the power cable connected.</li> </ul>
	<ul style="list-style-type: none"> <li>• If organic solvent ink is mixed with water or alcohol, coagulation is generated. Do not wipe the nozzle face of the heads, wiper, caps, etc. with water or alcohol. Doing so can cause nozzle clogging or machine failure.</li> <li>• Do not use benzene, thinner, or any chemical agent containing an abrasive. Such materials can deteriorate or deform the surface of the cover.</li> <li>• Do not apply a lubricant, etc. to any parts inside the machine. Doing so can cause printing failure.</li> <li>• Be careful that the cleaning solution, ink, etc. not to stick to the cover because this may cause the surface of the cover to deteriorate or deform.</li> <li>• Do not leave the machine for a long time with the cover opened. Ink may be cured due to outside light, and it may cause discharge defect.</li> </ul>

## About Cleaning Solution

Use the cleaning liquid dedicated for the ink being used.

Type of Ink	Applicable maintenance washings
SU100 ink, SU200 ink	Maintenance liquid 07 kit (ML007-Z-K1) Cleaning liquid 07 cartridge (FL007-Z-22) [Sold separately]



## Cleaning the Exterior Surfaces

When the exterior surfaces of the machine are stained, dampen a soft cloth with water or a neutral detergent diluted with water, squeeze it, and wipe the surfaces with the cloth.

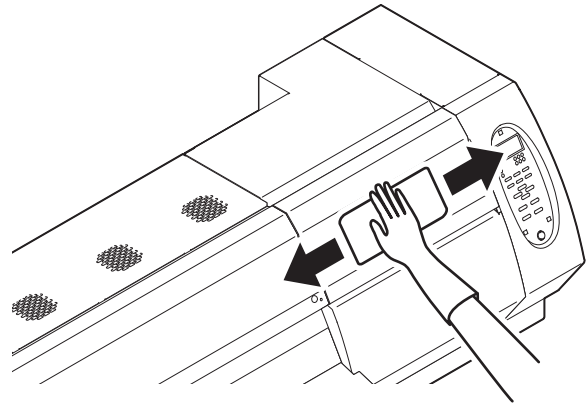

## Cleaning the Platen

The platen easily gets dirty with lint, paper dust, etc. generated when a media is cut. Wipe off conspicuous stains with a soft-hair brush, a dry cloth, a paper towel, etc.

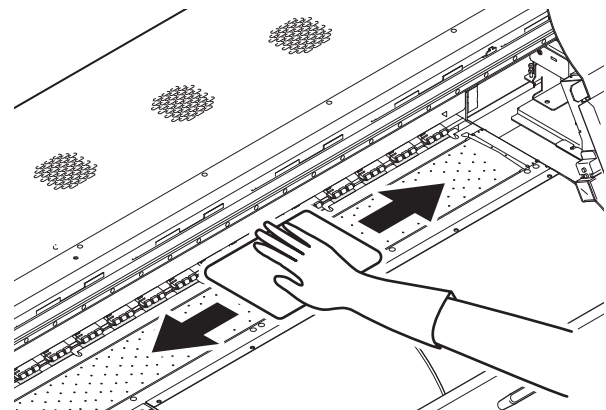

- When the platen is stained with ink, wipe it off with a paper towel containing a small amount of cleaning solution for maintenance.



- Before cleaning the platen, make sure that the platen has cooled adequately.
- Because dust and dirt are easily accumulated in the slots for holding a media and cutting paper (cutter slot), be sure to clean these parts carefully.

## Cleaning of after heater cover and pre heater cover

The after heater cover and the pre heater cover are easy to be dirty because of the powder of the medium etc. If it shows dirt, wipe it with a soft cloth soaked in water or waterish mild detergent and wrung.

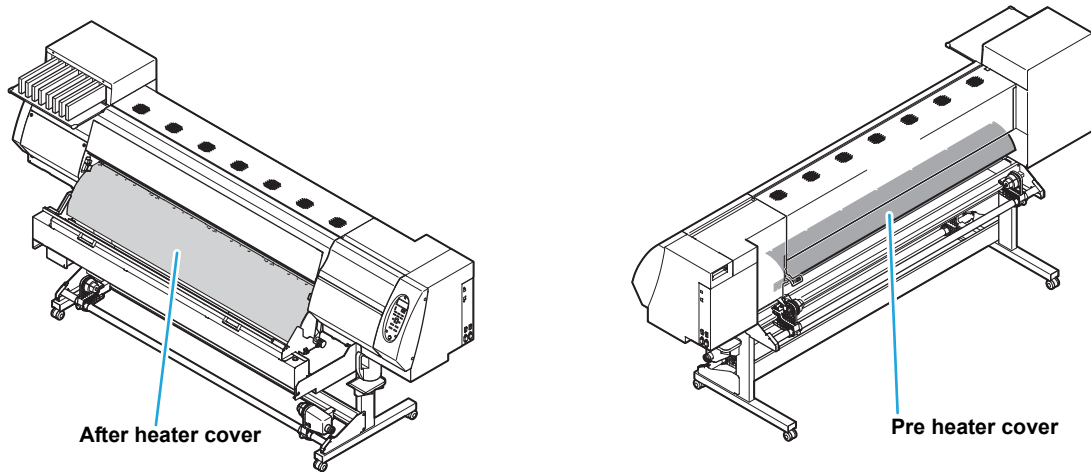

## Cleaning the Media Sensor

The media sensors are located on the platen in the backside and the bottom surface of the head. When the sensor is covered with dust, etc., it may cause false detection of media. Using a cotton swab, remove the dust, etc. accumulated on the surface of the sensor.

When cleaning the sensor on the lower surface of the head is cleaned, move the carriage to the left end by the operations of step 1 of P.4-19 "Cleaning the Head and the Area around It (every day)", and then clean it.

The backside of the machine

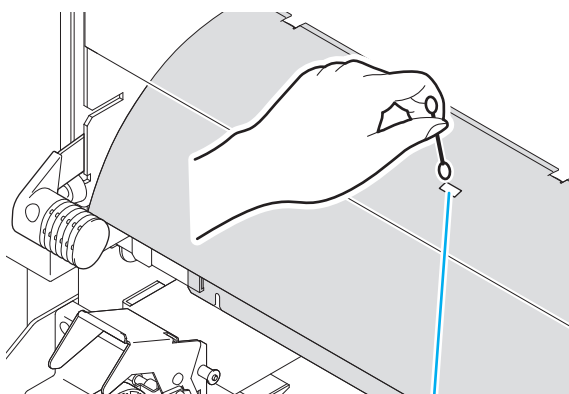

Media sensor

The lower surface of the head

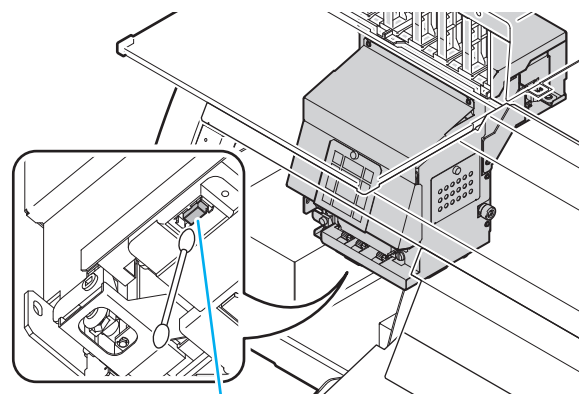

Media sensor

## Cleaning the Media Holder

When the media holder is covered with lint, dust, etc., a media cannot be fed normally during printing or dust sticks to the nozzles, which may result in abnormal printing. Clean the media holder regularly.

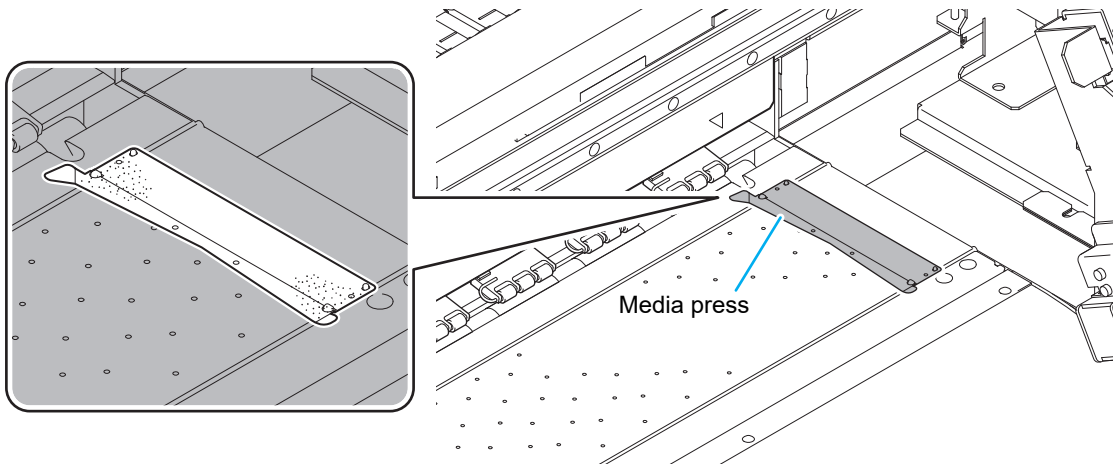

# Maintaining the Capping station

**Important!**

- To keep the nozzle status normal, perform wiper cleaning frequently.
- The right message is displayed periodically in LOCAL. When you press the **MAINT.** key, it moves to cleaning function.

Cleaning WIPER [MNT]

The ink cap and wiper function as follows.

- **Wiper** : It wipes off ink sticking to the head nozzles.
- **Ink cap** : It prevents the head nozzles from clogging due to dryness.

As the machine is used repeatedly, the wiper and ink cap gradually become dirty with ink, dust, etc. If nozzle missing cannot be corrected even after head cleaning (☞ P.2-19) has been performed, use a maintenance liquid 01 kit and clean stick.

Tools required for Maintenance	• Cleaning solution <b>When SU100 ink, SU200 ink is used: Maintenance liquid 07 kit (ML007-Z-K1)</b>		
	• Clean stick (SPC-0527)	• Gloves	• Safety glasses



- Be sure to wear the supplied safety glasses and gloves when maintaining the capping station. Otherwise, you may get ink in your eyes.
- Do not move the carriage out of the capping station by hand. When it is desirable to move the carriage, press the **MAINT.** key to execute the carriage-out. (☞ P.4-6 Steps 1 to 2)

## Cleaning the Wiper and Cap

It is recommended that the wiper and cap be cleaned frequently in order to maintain the high image quality of the machine and keep the machine itself in good working order.

**Important!**

- When solvent UV ink is used, the ink sticks around the wiper easily. Clean the wiper and the area around it about twice a week (it varies, depending on frequency in the use of the machine).
- Replace the wiper with a new one when it is extremely dirty or bent. (☞ P.4-34)
- When cleaning the wiper, be careful that lint from the clean stick does not get left on the wiper. Remaining lint may cause image quality to deteriorate.



- The shape of the area around the wiper has changed. Check the shape of the wiper slider of the machine you are using and perform maintenance in accordance with the shape.

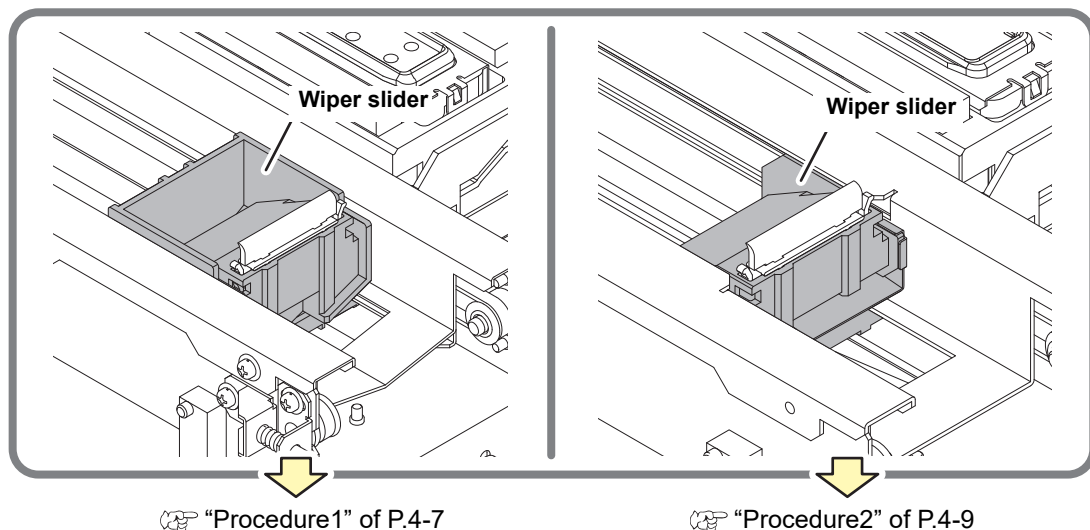

Procedure1

**1** Press the **MAINT.** key in LOCAL. CARRIAGE OUT  
[ ENT ]

**2** Press the **ENTER** key. MOVE POSITION  
: STATION MAINT.

**3** Press **▲ ▼** to select **[STATION MAINT.]**. MOVE POSITION  
: STATION MAINT.

**4** Press the **ENTER** key.  
 • The carriage moves to the maintenance position.

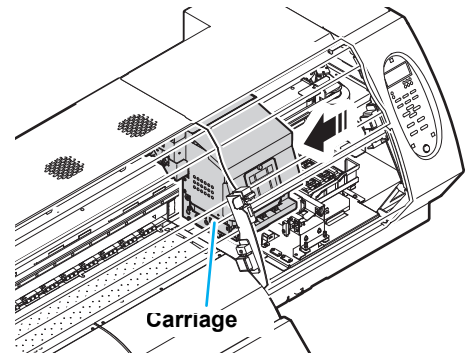

**5** Open the right maintenance cover cover then remove the wiper.  
 • Pull out the wiper by holding the protrusions at its both ends.

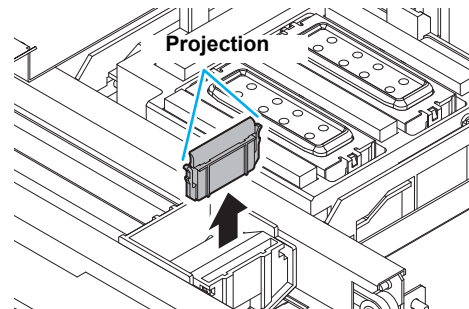

**6** Clean the wiper and bracket.  
 • Wipe off the ink sticking to the wiper and bracket with a clean stick dipped in maintenance liquid 07.  
 Wipe off so that maintenance liquid 07 will not remain.

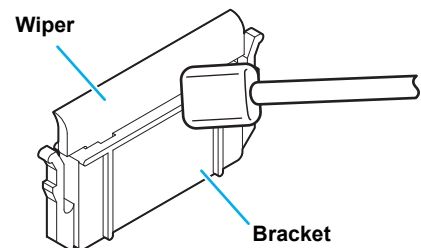

**7** Clean the wiper slider.  
 • Use a clean stick dipped in maintenance liquid 07 to wipe away any ink that has adhered to the edges of the wiper slider.  
 Also clean the slanting part inside the wiper slider, if it is dirty.  
 Wipe off so that maintenance liquid 07 will not remain.

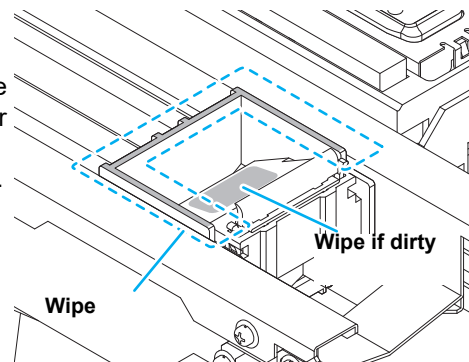

**8****Set the wiper at the original position.**

- Insert the wiper by holding both ends of the wiper.

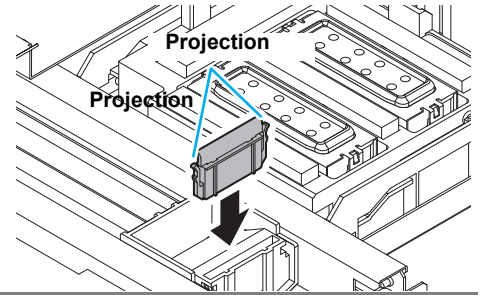
**9****Clean the cap rubber and cap rubber cover.**

- Wipe off the ink sticking to the cap rubber and cap rubber cover with a clean stick dipped in maintenance liquid 07. (Wipe off so that you can see color of the cap rubber.) Wipe off so that maintenance liquid 07 will not remain.
- The cap shape of SUJV-160 is different. (☞ P.1-9)

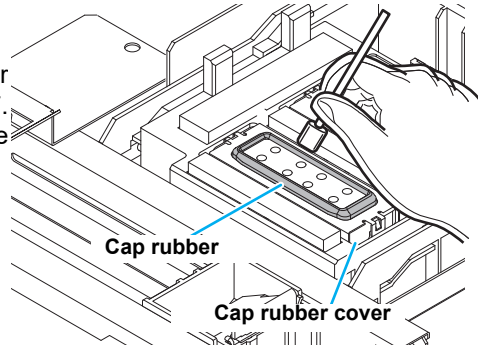
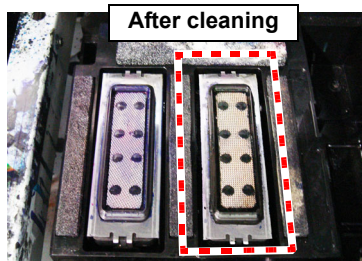
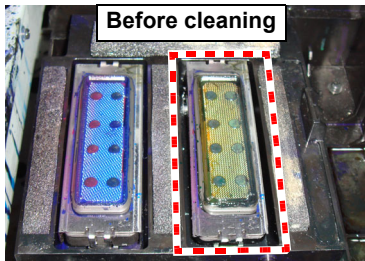
**Important!**

- At this point, clean the cap rubber only. Do not clean the mesh inside the cap. The mesh inside the cap is cleaned by executing "DISWAY WASH". (☞ P.4-12)

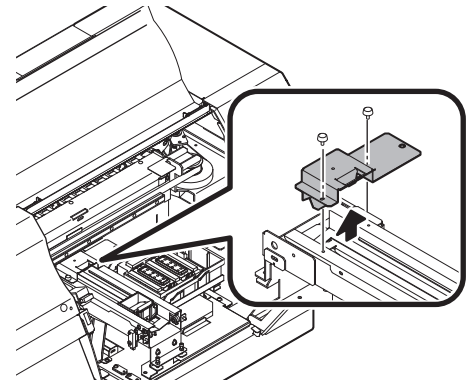
**10****Remove the ink guard.****11****Clean the ink guard.**

- Wipe off ink adhering to the front/ back surface of ink guard with a clean stick immersed in maintenance liquid 07. Wipe off so that maintenance liquid 07 will not remain.
- When cleaning has been completed, return the ink guard to the original status.

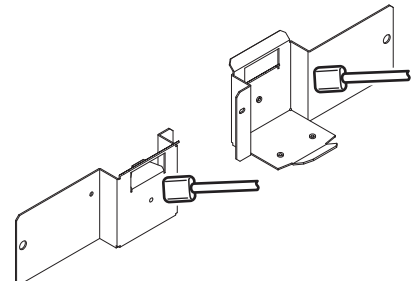

**12** Clean the area around the wiper.

- Dip the clean stick in the maintenance liquid07, and wipe clean the wiper guide upper portions and the portions one level below.

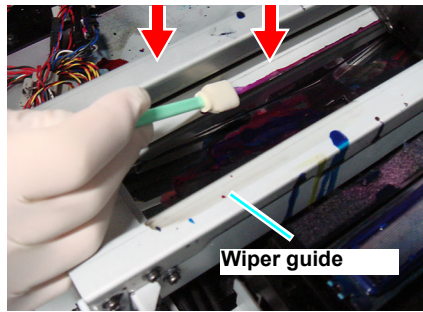
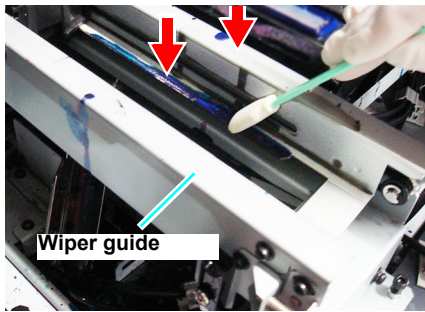

Wiper guide upper portions and portions one level below

**13** Press the **ENTER** key after the cleaning.

Close a cover  
COMPLETED [ENT]

**14** Close the right maintenance cover then press the **ENTER** key.

- After its initial operation, the machine returns to step1.

**Procedure2**

**1** Press the **MAINT.** key in LOCAL.

CARRIAGE OUT [ENT]

**2** Press the **ENTER** key.

MOVE POSITION  
:STATION MAINT.

**3** Press **▲▼** to select [STATION MAINT.].

MOVE POSITION  
:STATION MAINT.

**4** Press the **ENTER** key.

- The carriage moves to the maintenance position.

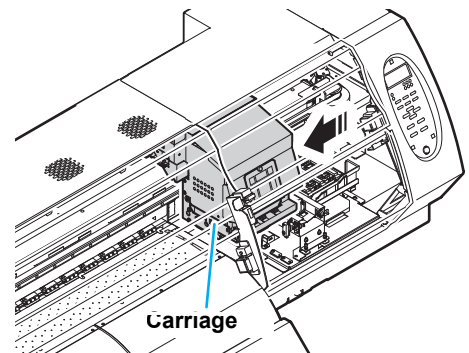

**5****Open the right maintenance cover cover then remove the wiper.**

- Pull out the wiper by holding the protrusions at its both ends.

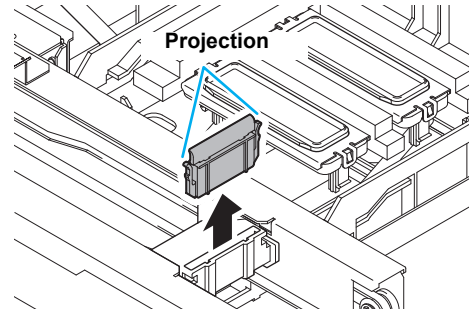
**6****Clean the wiper and bracket.**

- Wipe off the ink sticking to the wiper and bracket with a clean stick dipped in maintenance liquid 07.
- Wipe off so that maintenance liquid 07 will not remain.

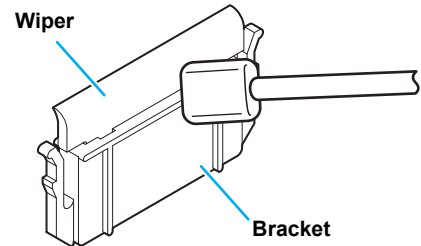
**7****Clean the wiper slider.**

- Wipe off the ink sticking to the wiper slider with a clean stick dipped in cleaning solution for maintenance.
- Wipe off so that cleaning solution for maintenance will not remain.

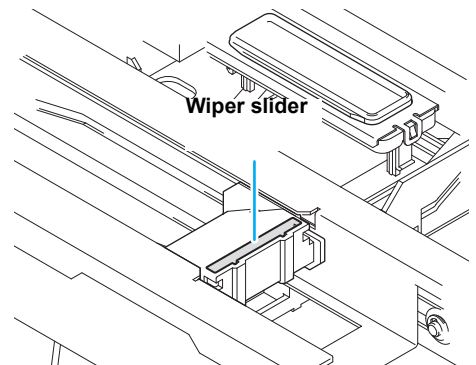
**8****Set the wiper at the original position.**

- Insert the wiper by holding both ends of the wiper.

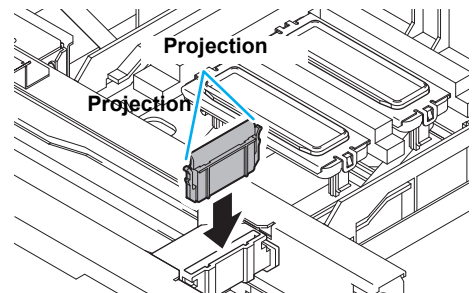
**9****Clean the cap rubber and cap rubber cover.**

- Wipe off the ink sticking to the cap rubber and cap rubber cover with a clean stick dipped in maintenance liquid 07. (Wipe off so that you can see color of the cap rubber.) Wipe off so that maintenance liquid 07 will not remain.
- The cap shape of SUJV-160 is different. (☞ P.1-9)

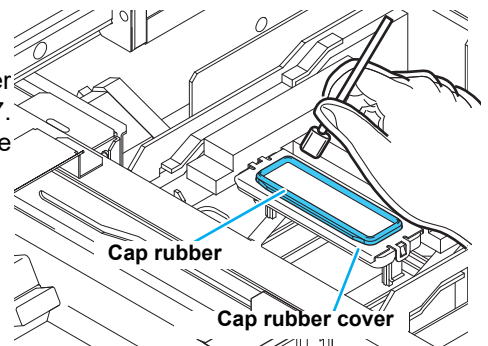
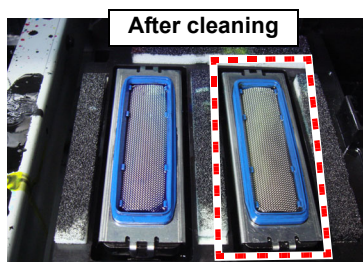
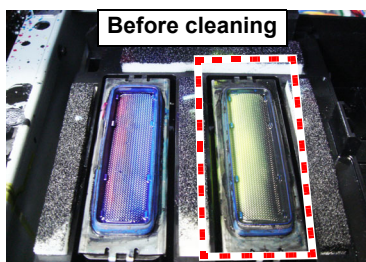
**Important!**

- At this point, clean the cap rubber only. Do not clean the mesh inside the cap. The mesh inside the cap is cleaned by executing "DISWAY WASH". (☞ P.4-12)



**10** Remove the ink guard.

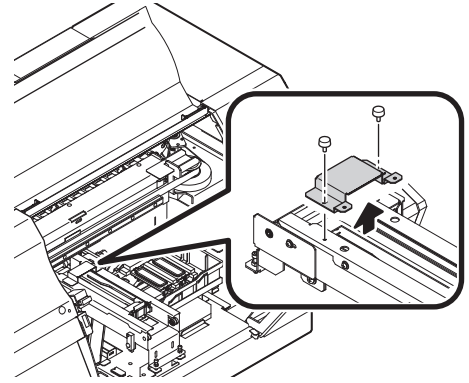

**11** Clean the ink guard.

- Wipe off ink adhering to the front/ back surface of ink guard with a clean stick immersed in maintenance liquid 07. Wipe off so that maintenance liquid 07 will not remain.
- When cleaning has been completed, return the ink guard to the original status.

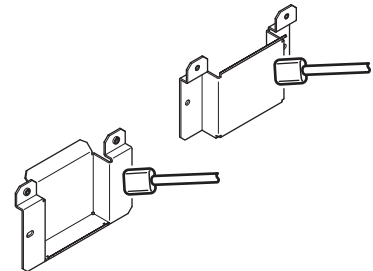

**12** Use a clean stick to clean the areas around the wiper shown in the figures.

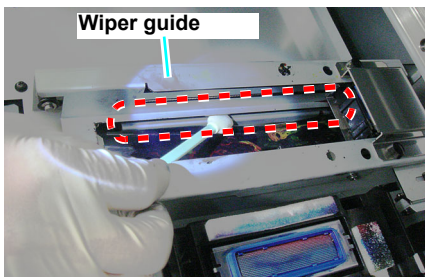

Space below the wiper guide

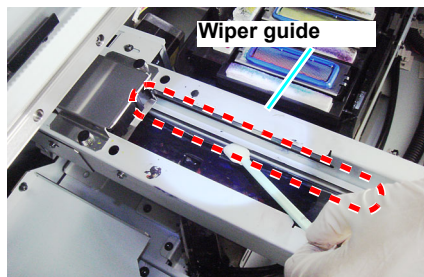

Space between the wiper slider and wiper guard W

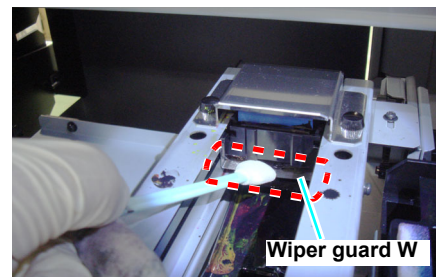

**13** Press the **ENTER** key after the cleaning.

Close a cover  
COMPLETED [ENT]

**14** Close the right maintenance cover then press the **ENTER** key.

- After its initial operation, the machine returns to step1.

**Performing the station maintenance without **MAINT.** key**

You can select station maintenance by using the **FUNCTION** key in the Local without pressing the **MAINT.** key.

Press the **FUNCTION** key in Local.

Press **▲ ▼** to select **[MAINTENANCE]**.

Press the **ENTER** key twice.

- It becomes the same condition as the **MAINT.** key is pressed from Local.

## Washing the Ink Discharge Passage (DISWAY WASH)

**Important!**

- Wash the ink discharge passage regularly (about once a week) to prevent the head nozzles from clogging due to ink coagulation inside the passage.

**1**

Press the **MAINT.** key in LOCAL.

CARRIAGE OUT  
[ ENT ]

**2**

Press **▲ ▼** to select [DISWAY WASH].

DISWAY WASH  
[ ENT ]

**3**

Press the **ENTER** key.

- The carriage moves to the maintenance position.
- Dry suction operation is performed repeatedly until the washing work is completed.
- If the cleaning solution cartridge is usable, automatic washing is performed and the operation is completed. If the cleaning solution cartridge is not usable, the procedures in the Step 4 and after are performed.

DISWAY WASH  
COMPLETED  
[ ENT ]

**4**

Open the right maintenance cover.

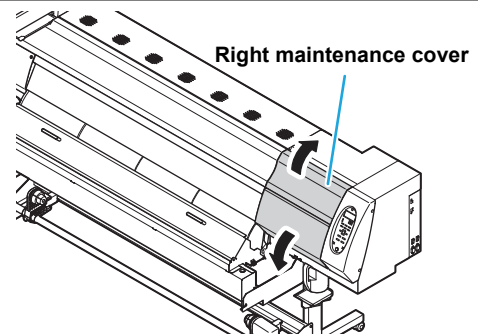

**5**

Fill up the cap with cleaning solution for maintenance.

- If the maintenance solution cartridge is usable, maintenance solution is automatically filled.
- If the maintenance solution cartridge is not usable, suck maintenance solution into a dropper and fill up the cap with it. Fill up the cap with maintenance solution on the verge of overflow from the cap.
- The cap shape of SUJV-160 is different. (P.1-9)

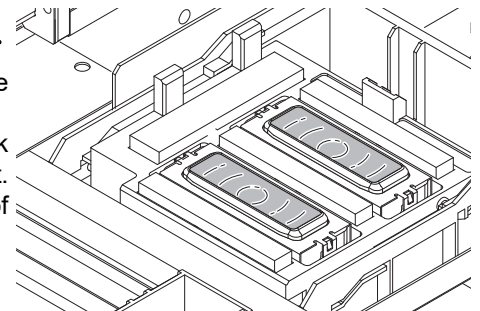
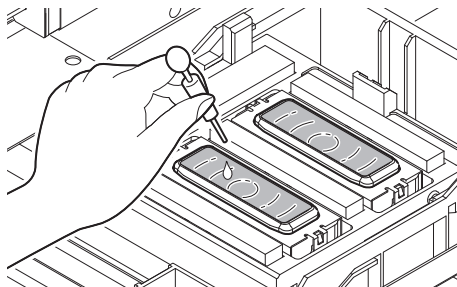

**6**

Close the right maintenance cover and press the **ENTER** key.

- After the idle absorbing operation has been performed for 30 seconds, the screen returns to step2.

DISWAY WASH  
PLEASE WAIT

## When the Machine Is Not Used for a Long Time (CUSTODY WASH)

When the machine is not going to be used for a week or more, use the cleaning function for custody to clean the head nozzles and ink discharge passage. After this, keep the machine in custody.

**Important!**

- Use the machine with always turning "ON" the main power. The function preventing nozzle clogging operates automatically to protect the head of the nozzle.
- The head nozzle may result in nozzle clogging if the main power switch is left OFF for a long time.

<b>Check the items on the right beforehand.</b>	<p><b>Is [NEAR END] or [INK END] displayed?</b></p> <ul style="list-style-type: none"> <li>• The cleaning solution or ink is absorbed when the nozzles are washed. At this time, if the state of "no ink" or "almost no ink" is detected, the nozzle washing operation cannot start.</li> <li>• Replace the cartridge with another from which the state of "almost no ink" or "no ink" is not detected.</li> </ul>
---	--



- When the following messages are indicated, check the waste ink tank, and then operate it, referring to P.4-35 "If a Waste Ink Tank Confirmation Message Appears" according to the situation.

Check waste ink [ENT]

**1**

Press the **MAINT.** key in LOCAL.

CARRIAGE OUT [ENT]

**2**

Press **▲ ▼** to select [CUSTODY WASH].

CUSTODY WASH [ENT]

**3**

Press the **ENTER** key.

- The carriage moves to the maintenance position.

WIPER CLEANING COMPLETED [ENT]

**Important!**

- Until wiper/ bracket cleaning is completed, [COMPLETED (NEXT): ENT] is displayed on the screen. After the work up to the step 4 is completed, press the **ENTER** key. If you press the **ENTER** key before cleaning is completed, the machine moves to the next washing procedure.

**4**

**Clean the wiper and the bracket.**

- (1) Open the right maintenance cover then pull out it by holding projections at both ends of the wiper.
- (2) Clean the wiper and bracket with a clean stick dipped in cleaning solution for maintenance. (ML007-Z-K1) Wipe off so that cleaning solution for maintenance will not remain.
- (3) Insert it in the original position by holding the projections at both ends of the wiper.

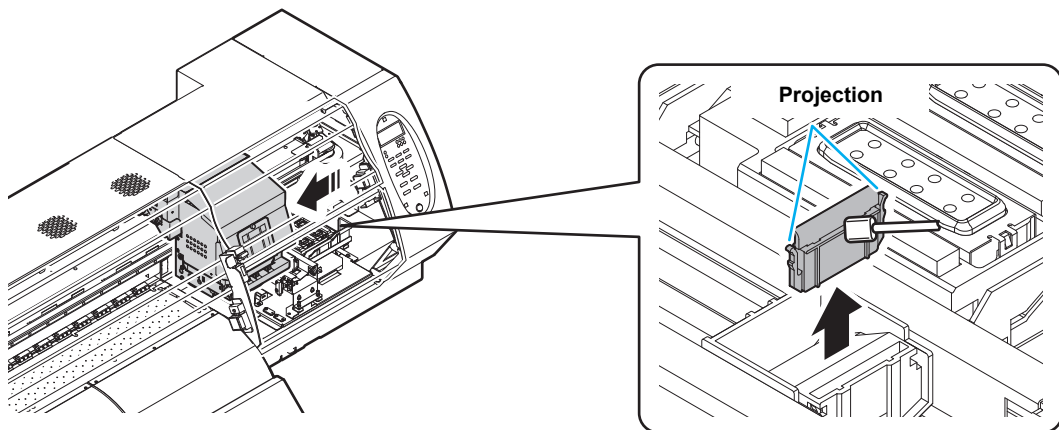

**4**

**5****Press the **ENTER** key.**

- The carriage moves onto the platen.

CAP CLEANING COMPLETED (NEXT) [ENT]
--

**Important!**

- Until wiper cleaning is completed, [COMPLETED (NEXT): ENT] is displayed on the screen. After the work up to the step 6 is completed, press the **ENTER** key. If you press the **ENTER** key before cleaning is completed, the machine moves to the next washing procedure.

**6****Clean the cap rubber and cap rubber cover.**

- Wipe off the ink sticking to the cap rubber and cap rubber cover with a clean stick dipped in maintenance solution for maintenance. (Wipe off so that you can see blue color of the cap rubber.) Wipe off so that maintenance solution for maintenance will not remain.
- At this time, the discharge passage is cleaned automatically.
- The cap shape of SUJV-160 is different. (P.1-9)

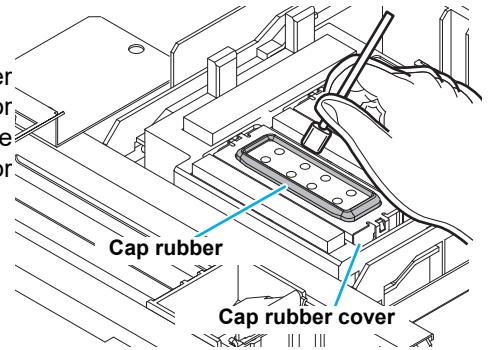
**7****Press the **ENTER** key.****Important!**

- Until washing liquid is filled, [COMPLETED (NEXT): ENT] is displayed on the screen. After the work up to the Step 8 is completed and you close the right maintenance cover, press the **ENTER** key. If you press the **ENTER** key before washing liquid is filled, the carriage returns to the original position.

Fill the liquid COMPLETED (NEXT) [ENT]
---

**8****Fill up the cap with cleaning solution for maintenance.**

- If the maintenance solution cartridge is usable, maintenance solution is automatically filled. If there is not enough maintenance solution, press the **FUNCTION** key to add maintenance solution.
- If the maintenance solution cartridge is not usable, suck maintenance solution into a dropper and fill up the cap with it. Fill up the cap with maintenance solution on the verge of overflow from the cap.
- The cap shape of SUJV-160 is different. (P.1-9)

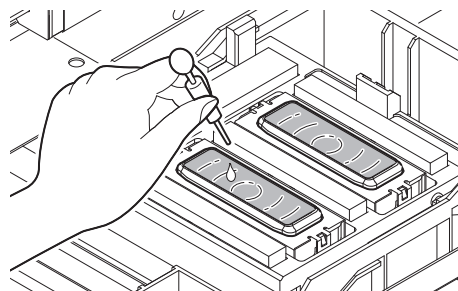
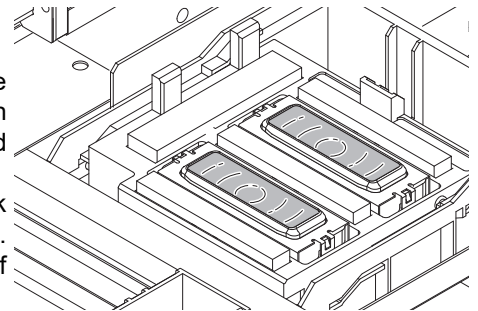
**9****Close the right maintenance cover and press the **ENTER** key.**

LEAVING TIME	
=	1min

**10****Press **▲** **▼** to set the time for the cleaning solution to be left as it is.**

- Set Value: 1 to 99 min (by the unit of 1 min)

LEAVING TIME	
=	2min

**11** Press the **ENTER** key.

DISWAY WASH  
COMPLETED [ENT]

- The nozzles are washed.
- When the nozzles have been completely washed, the head moves to the maintenance position.
- If the maintenance solution cartridge is usable, washing the ink discharge passage is performed automatically and operation is completed. If the maintenance solution cartridge is not usable, the procedures in the step12 and after are performed.

**12** Open the right maintenance cover.

**13** Fill up the cap with cleaning solution for maintenance.

- If the maintenance solution cartridge is usable, maintenance solution is automatically filled.
- If the maintenance solution cartridge is not usable, suck maintenance solution into a dropper and fill up the cap with it. Fill up the cap with maintenance solution on the verge of overflow from the cap.
- The cap shape of SUJV-160 is different. (P.1-9)

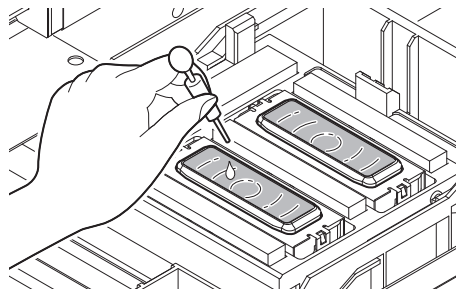
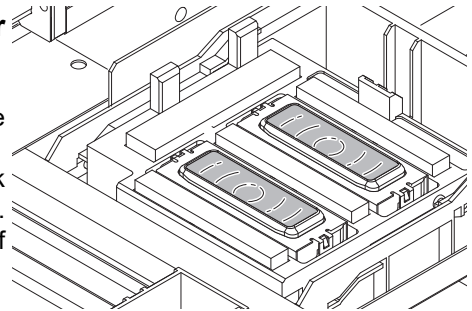

**14** Close the right maintenance cover and press the **ENTER** key.

\*Being Initialized\*  
PLEASE WAIT

- After its initial operation, the machine returns to step2.

## NOZZLE PROTECT function

When the printer is not used for a certain time under high-temperature and high-humid conditions, missing nozzles or incorrect jetting angle may occur.

In order to prevent such defects, nozzles should be protected. Take countermeasures described below when the printer is stored at 30°C or higher for more than 24 hours.

### Execute the NOZZLE PROTECT function

<b>Make sure the followings in advance.</b>	<p><b>Is the maintenance cleaning liquid set?</b></p> <ul style="list-style-type: none"><li>• Please make sure to set the maintenance cleaning liquid. Nozzle protect function cannot be performed if the liquid is not set or the set liquid level is low.</li><li>• When the maintenance liquid is not set or the liquid level is low, a warning message is indicated as follows.</li></ul> <p><b>Is a warning message indicating about the ink waste tank?</b></p> <ul style="list-style-type: none"><li>• When a warning message [Check waste ink ] is indicated, the nozzle protect function cannot be performed. According to P.4-35 "If a Waste Ink Tank Confirmation Message Appears" clear the warning.</li></ul>
---	--

**1**

Press the **MAINT.** key in LOCAL.

CARRIAGE OUT  
[ ENT ]

**2**

Press **▲** **▼** to select [NOZZLE PROTECT].

NOZZLE PROTECT  
[ ENT ]

**3**

Press the **ENTER** key.

NOZZLE PROTECT  
EXECUTE . [ ENT ]

**4**

Press the **ENTER** key.

- The NOZZLE PROTECT function is executed.
- When NOZZLE PROTECT function is finished, the power is automatically turned off and the machine enters a nozzle protection status.
- In the nozzle protection status, it executes NOZZLE PROTECT regularly. Keep the main power switch on. Also, check that it has enough maintenance washing liquid.

**Important!**

- When the printer is not used for a long time, check the fluid level in the waste ink tank.
- In the nozzle protection status, maintenance in the sleep status does not work.
- When turning on the printer after the nozzle protect function is performed, the printer automatically performs following operations. After these operations are completed, start test pattern printing and then check the nozzle conditions.
  - (1) Discharges washing liquid filled in the cap.
  - (2) Executes head cleaning automatically.

## Executes the NOZZLE PROTECT function automatically

You can set the status to enter the nozzle protection automatically (auto-execute function of NOZZLE PROTECT) in case the device is not used for a certain amount of time.

In the nozzle protection status, NOZZLE PROTECT can be automatically executed regularly.

To use the auto-execute function of NOZZLE PROTECT, set the following items.

- **On Time** : Time from the stop of the device to the start of the nozzle protection status.
- **Interval** : The interval time between each filling\* operation while the nozzle protect function is activated.  
\* The cleaning liquid is filled into nozzle at constant time interval.



- The machine not being used means that it is in the standby status or the status that the power supply switch under the operation panel is OFF (the sleep status).
- The followings are the examples (three patterns) if you set the time length until the NOZZLE PROTECT function is executed to "16h".

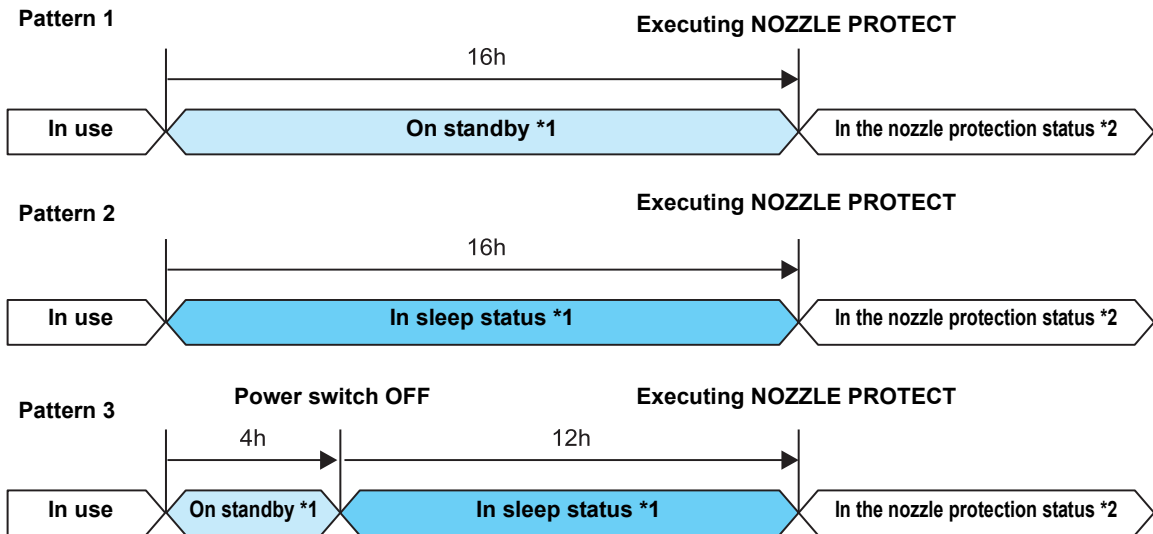

\*1 : If the time length set in "" has passed, maintenance operation is executed automatically.

\*2 : In the nozzle protection status, a maintenance function set at "" does not work.  
After entering the nozzle protection status, this machine automatically performs depending on interval of NOZZLE PROTECT regularly.



- When the printer is not used for a long time, check the fluid level in the waste ink tank.

**1**

Select [AutoNZL.PROTECT] of the maintenance menu.

- (1) Press the **FUNCTION** key in the local mode.
- (2) Select [MAINTENANCE] by pressing the **▲▼** keys then press the **ENTER** key.
- (3) Select [AutoNZL.PROTECT] by pressing the **▲▼** keys.

**2**

Press the **ENTER** key.

ON Timm  
= 16 h

**3**

Press **▲▼** to set the time length until the NOZZLE PROTECT is executed.

ON Timm  
= 3 h

Set value : OFF, 1 to 24 hours (Default value:16 hours)

**4**

Press the **ENTER** key.

- “ON Time” setting ends. Following this, set “INTERVAL”.
- “Interval” is set to three days as default. If changing is not needed, press the **END** key several times to end the setting.
- When set the time “OFF” on the above procedure number “3”, skip to the procedure “7”.

INTERVAL  
= 10 d

**5**

Press **▲▼** to set an execution interval (number of days) of NOZZLE PROTECT.

INTERVAL  
= 7 d

Set value : OFF, 1 to 14 days

**6**

Press the **ENTER** key.

MSINTENANCE  
AutoNZL.PROTECT[ENT]

**7**

Press the **END** key several times to end.



# Cleaning the Head and the Area around It (every day)

Because the head employs a very precise mechanism, due care needs to be taken when it is cleaned. Using a clean stick, etc., rub off gelatinous ink or dust that may stick to the lower part of the slider and the area around the head. In doing so, never rub the nozzles of the head.

<b>Tools required for cleaning</b>	• Clean stick (SPC-0527)	• Gloves	• Safety glasses
------------------------------------	--------------------------	----------	------------------



- Be sure to wear the attached safety glasses and gloves when cleaning the area around the head. Otherwise, you may get ink in your eyes.
- The ink contains organic solvent. If you get the ink on your skin or in your eyes, wash it away with plenty of water immediately.

**1** Press the **MAINT.** key in LOCAL. CARRIAGE OUT  
[ ENT ]

**2** Press the **ENTER** key. MOVE POSITION  
: STATION MAINT.

**3** Press **▲ ▼** to select [HEAD MAINT.]. MOVE POSITION  
: HEAD MAINT.

**4** Press the **ENTER** key.  
• Carriage will move to the left end of this device.

**5** Open the left maintenance cover.

- (1) Turn four screws that fix the maintenance cover to the left, and remove them.
- (2) Remove the maintenance cover.

• If the maintenance cover is hard to remove, use the supplied screwdriver.

**6**

**Wipe ink sticking to the side of the head off with a clean stick.**

- To prevent gelled/ solid ink ground from pooling at the front and rear of the carriage, scrape them off with clean stick etc.
- Clean the side surface of the head (shown in deep gray) with a clean stick.
- Never rub the nozzles.

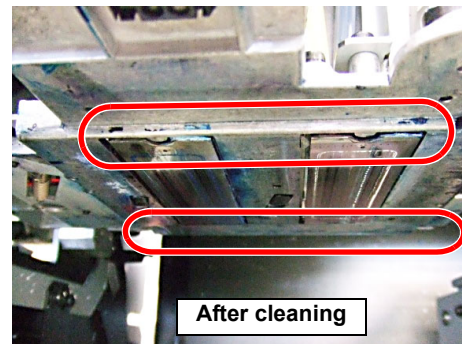
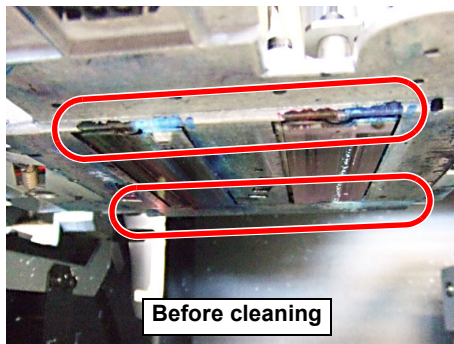
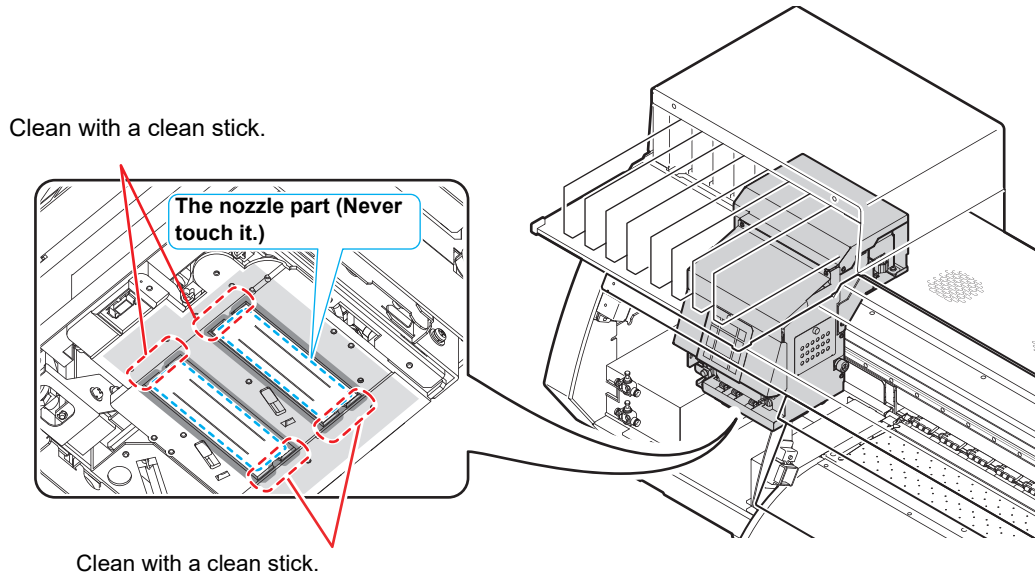

**7**

**Press the **ENTER** key after the cleaning.**

Close a cover  
COMPLETED [ENT]

**8**

**Close the left maintenance cover then press the **ENTER** key.**

- After its initial operation, the machine returns to step1.

# Replacing method of C absorber kit

If ink adheres to the C absorber, it is required to replace the C absorber.

## Rough guide for replacement:

Replace when the concavity and convexity of the surface of the absorber are filled with ink as indicated in the right photo.

In addition, when you replace the C absorber, clean ink adhering to the capping station at the same time.

- The cap shape of SUJV-160 is different. (☞ P.1-9)



- To replace the C absorber, the C absorber replacing kit (SPA-0185) separately sold is required. Contact a distributor in your district or our office for purchasing it.

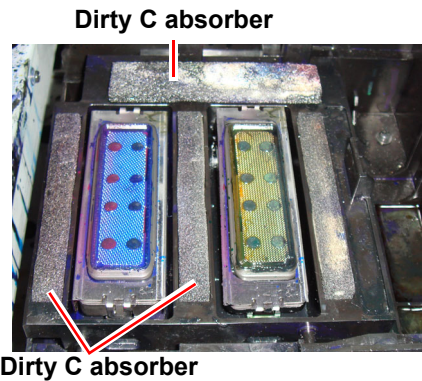

1

Press the **MAINT.** key in LOCAL.

CARRIAGE OUT  
[ ENT ]

2

Press the **ENTER** key.

MOVE POSITION  
: STATION MAINT .

3

Press **▲ ▼** to select [STATION MAINT.].

MOVE POSITION  
: STATION MAINT .

4

Press the **ENTER** key.

- The carriage moves to the maintenance position.

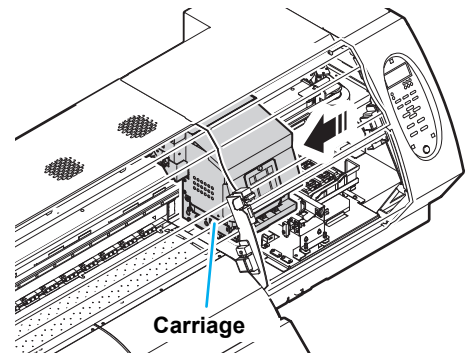

5

Open the right maintenance cover then remove the C absorber.

- Pull out the C absorbers (x 4).

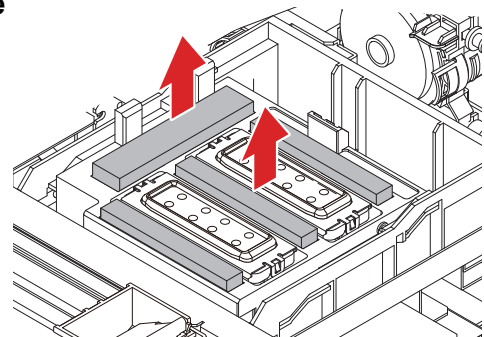

4

Routine Maintenance

# 6

## Insert a new C absorber.

- There are two types' absorbers and four in total (C absorber x 1, C absorber 2 x 3).
- Be careful not to mess up the positions to which they are inserted.

**Important!**

- Check whether stick out part of the station is inserted to slit of the C absorber/ C absorber 2.

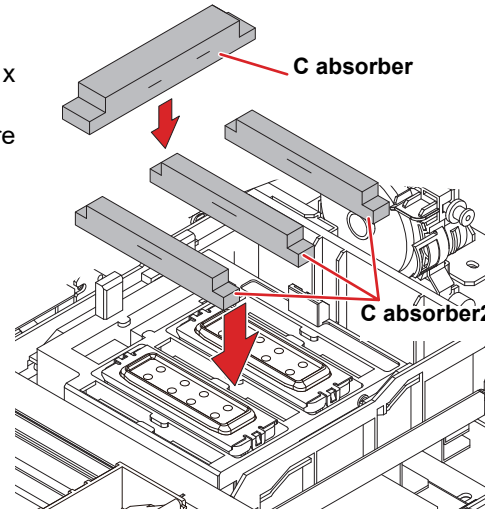
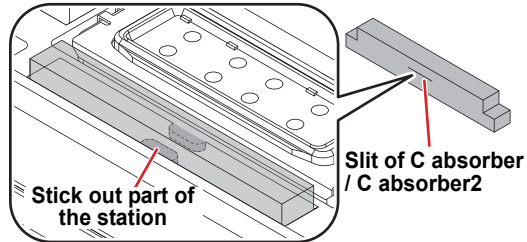

# 7

## Press the **ENTER** key after the cleaning.

Close a cover  
COMPLETED [ENT]

# 8

## Close the right maintenance cover then press the **ENTER** key.

- After its initial operation, the machine returns to step1.

# When Nozzle Clogging Cannot Be Solved

When nozzle clogging cannot be solved even after the head cleaning (☞ P.2-19) has been done, perform the following two functions:

<b>NOZZLE WASH</b>	• Wash the head nozzle. (☞ P.4-23)
<b>NOZZLE RECOVERY</b>	• Alternative nozzles for printing, when nozzles missing can not be improved. (☞ P.4-28)

## Washing of Head nozzle

Perform cleaning of the nozzles in the heads to prevent them being clogged with coagulated ink.

<b>Check the items on the right beforehand.</b>	<p><b>Is [NEAR END] or [INK END] displayed?</b></p> <ul style="list-style-type: none"> <li>• The cleaning solution or ink is absorbed when the nozzles are washed. At this time, if the state of "no ink" or "almost no ink" is detected, the nozzle washing operation cannot start.</li> <li>• Replace the cartridge with another from which the state of "almost no ink" or "no ink" is not detected.</li> </ul>
---	--

**1** Press the **MAINT.** key in LOCAL.

CARRIAGE OUT [ENT]

**2** Press **▲ ▼** to select **[NOZZLE WASH]**.

NOZZLE WASH [ENT]

**3** Press the **ENTER** key.

- The carriage moves to the maintenance position.

WIPER CLEANING COMPLETED (NEXT) [ENT]

- Important!**
- Until wiper cleaning is completed, [COMPLETED (NEXT); ENT] is displayed on the screen. After the work up to the step 4 is completed, press the **ENTER** key. If you press the **ENTER** key before cleaning is completed, the machine moves to the next washing procedure.

**4** Clean the wiper and the bracket.

- (1) Open the right maintenance cover then pull out it by holding projections at both ends of the wiper.
- (2) Clean the wiper and bracket with a clean stick dipped in cleaning solution for maintenance. (ML007-Z-K1) Wipe off so that cleaning solution for maintenance will not remain.
- (3) Insert it in the original position by holding the projections at both ends of the wiper.

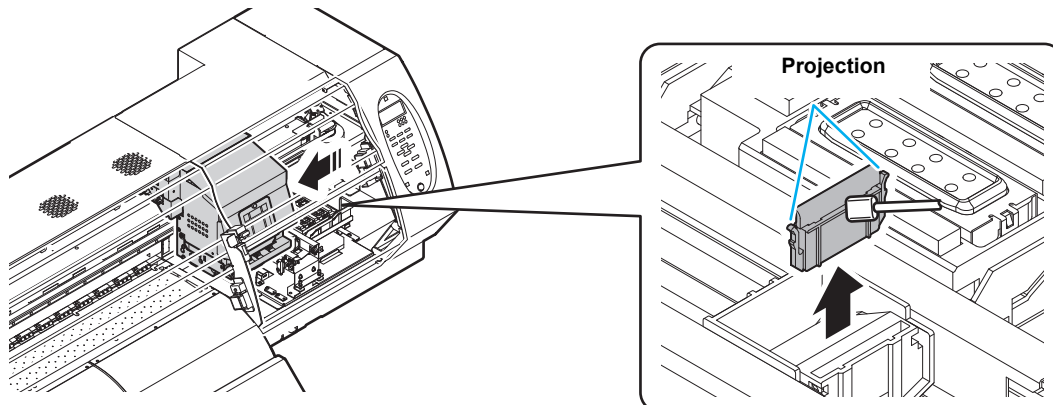

**5****Press the **ENTER** key.**

- The carriage moves onto the platen.

**Important!**

- Until wiper cleaning is completed, [COMPLETED (NEXT): ENT] is displayed on the screen. After the work up to the step 6 is completed, press the **ENTER** key. If you press the **ENTER** key before cleaning is completed, the machine moves to the next washing procedure.

CAP CLEANING COMPLETED (NEXT) [ ENT ]
--

**6****Clean the cap rubber and cap rubber cover.**

- Wipe off the ink sticking to the cap rubber and cap rubber cover with a clean stick dipped in cleaning solution for maintenance. Wipe off so that cleaning solution for maintenance will not remain.
- At this time, the discharge passage is cleaned automatically.
- The cap shape of SUJV-160 is different. (☞ P.1-9)

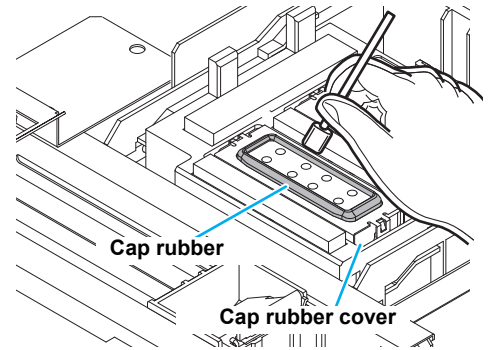
**7****Press the **ENTER** key.****Important!**

- Until washing liquid is filled, [COMPLETED (NEXT): ENT] is displayed on the screen. After the work up to the Step 8 is completed and you close the right maintenance cover, press the **ENTER** key. If you press the **ENTER** key before washing liquid is filled, the carriage returns to the original position.

Fill the liquid COMPLETED (NEXT) [ ENT ]
---

**8****Fill up the cap with cleaning solution for maintenance.**

- If the maintenance solution cartridge is usable, maintenance solution is automatically filled. If there is not enough maintenance solution, press the **FUNCTION** key to add maintenance solution.
- If the maintenance solution cartridge is not usable, suck maintenance solution into a dropper and fill up the cap with it. Fill up the cap with maintenance solution on the verge of overflow from the cap.
- The cap shape of SUJV-160 is different. (☞ P.1-9)

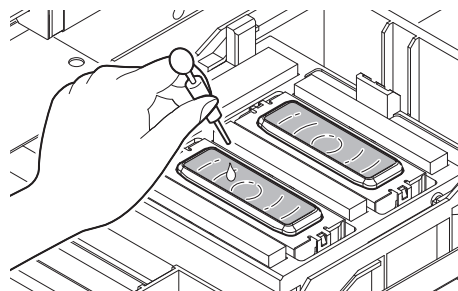
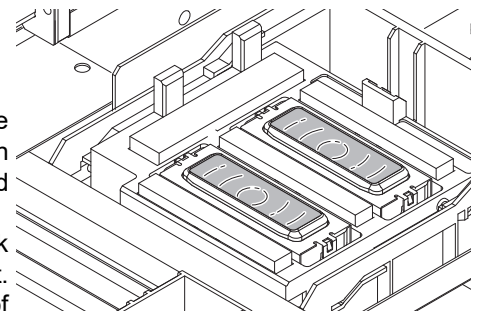
**9****Close the right maintenance cover then press the **ENTER** key.**

NOZZLE WASH LEAVING TIME	: 1 min
-----------------------------	---------

**10****Press **▲** **▼** to set the time for the cleaning solution to be left as it is.**

- **Set value** : 1 to 99 minutes (Unit: minute)

NOZZLE WASH LEAVING TIME	: 2 min
-----------------------------	---------

**11****Press the  key.**

- The cleaning solution filled in the cap is absorbed.
- The screen on the right is displayed only for the duration set in the step 10.
- It returns to the step2 after the duration.

PLEASE WAIT  
00:00



\*\* CLEAMING \*\*  
PLEASE WAIT

**Important!**

- When nozzle missing is not cleared even after nozzle recovery ( P.4-28) or this washing is carried out several times, contact the distributor in your region or our service office.
- When this machine is not filled with cleaning solution for maintenance, do the following:
  - (1) Perform the operations in Steps 1 to 5.
  - (2) Fill up the cap with cleaning solution for maintenance, using a syringe.
  - (3) Perform the operations in Step 7 and later.

## When nozzle missing occurs due to ink mixture or aeration

Push out ink and air in the head from the port.

Use this when ink has been mixed in the port, or nozzle missing due to aeration occurs.

### 1 Select [AIR PG] of the maintenance menu.

- (1) Press the **FUNCTION** key in LOCAL.
- (2) Press **▲** **▼** to select [MAINTENANCE] and press the **ENTER** key.
- (3) Press **▲** **▼** to select [AIR PG].

### 2 Press the **ENTER** key.

SELECT SUBTANK  
: MMCCYYKK

### 3 Select the subtank to air purge.

- Select the subtank with the **◀** **▶** key.

SELECT SUBTANK  
: MMCC\_ \_ \_ \_

### 4 Press the **ENTER** key.

PREPARE AIR PG  
COMPLETED [ENT]

### 5 Open the right maintenance cover, and set the jig into the port.

- Remove the port corresponding to the subtank selected in the Step 3 only. Perform this one by one.



- When removing the jig, ink may leak. Put a paper towel etc. around the port.

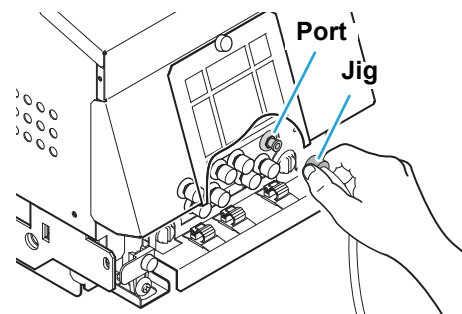
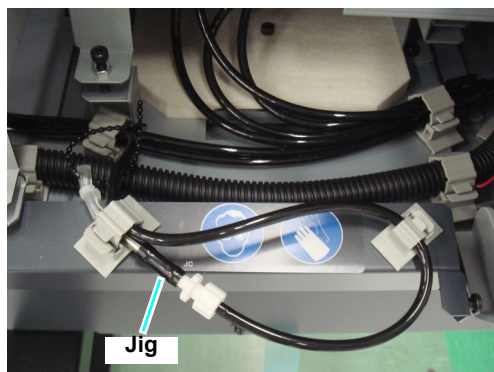

### 6 Press the **ENTER** key.

AIR PG  
START [ENT]



**7**

Press **ENTER** key first and press **FUNCTION** key and then wait for 10 seconds.

- Start pushing ink out.

```
AIR PG
COMPLETED [ENT]
```

**8**

Terminate air purge by pressing the **ENTER** key.

- Close the port.
- When you perform air purge of other port, you can return to the Step 2 by pressing **▶**.



- When removing the jig, ink may leak. Put a paper towel etc. around the port.

```
AIR PG
END < > RETRY
```

**9**

Press the **◀** key.

- Cleaning is performed.

```
** CLEANING **
PLEASE WAIT
```

**10**

Press **END** the key several times to end the setting.

# Alternative nozzles for printing, when nozzles missing can not be improved

NOZZLE RECOVERY: When nozzles missing can not be improved at specific points, other good nozzles can be used as alternatives for printing.

## 1 Select [NOZZLE RECOVERY] of the maintenance menu.

- (1) Press the **FUNCTION** key in LOCAL.
- (2) Press **▲** **▼** to select [MAINTENANCE] and press the **ENTER** key.
- (3) Press **▲** **▼** to select [NOZZLE RECOVERY].
- (4) Press the **ENTER** key.

## 2 Select the [PRINT] by pressing **▲** **▼** key. Then press **ENTER** key.

- Select "ENTRY" then "Move to select of the Nozzle line (Step 4) without drawing a pattern"

NOZZLE RECOVERY  
: PRINT



NOZZLE RECOVERY  
PRINT [ENT]

## 3 Press the **ENTER** key.

- 4色モデルの場合を例に説明します。

\*\* PRINTING \*\*  
PLEASE WAIT

Overhead view

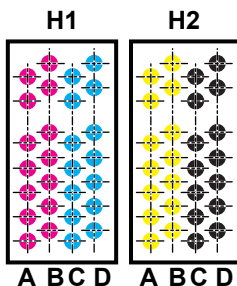

Nozzle line

Nozzle pattern

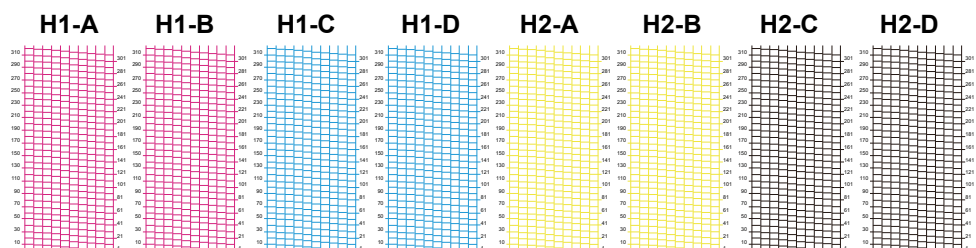

## 4 Select the Nozzle line that needs NOZZLE RECOVERY by pressing **▲** **▼** key. Then press **ENTER** key.

SELECT NOZZLE  
: H1-A

Ink color: Nozzle line

Head No.: H1 to H2

# 5

Register the Nozzle number that needs **NOZZLE RECOVERY** and then press **ENTER** key.

- (1) Select the registration number from 1 to 10 by pressing **▲▼** key and press the **ENTER**.
  - (2) Register the nozzle number that needs recovery by pressing **▲▼** key and press the **ENTER**.
- Check is performed at the same time of the registration. When there is a mode for which nozzle recover is invalid, the screen of the Step 3 of “Check the print condition for which nozzle recovery cannot be performed”.

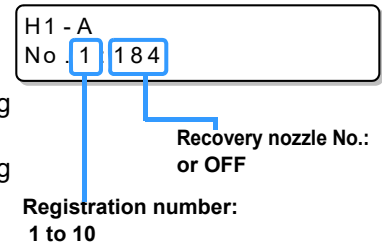

Example of nozzle to be recovered

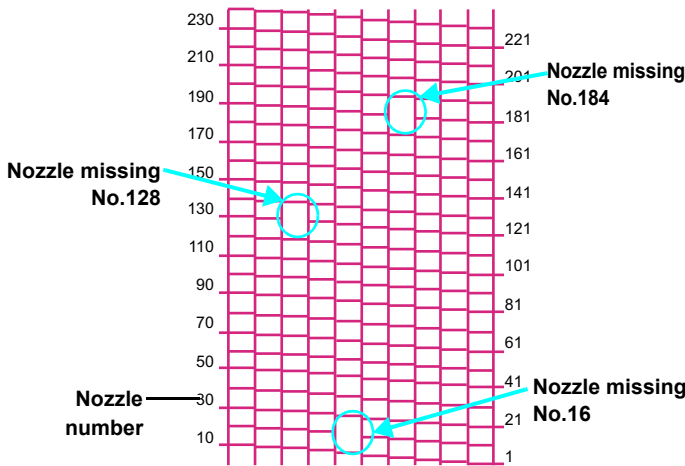

Registration number	Recovery Nozzle No.	State
1	16	Target for nozzle recovery
2	128	Target for nozzle recovery
3	184	Target for nozzle recovery
4	OFF	No registration
5	OFF	No registration

# 6

Press the **END** key several times to end the setting.



- Up to 10 nozzles can be registered per 1 nozzle line.
- Even if you use this function, time required for drawing does not change.
- Depending on the registered nozzle, there is a mode on which recovery is not reflected. Check the print condition for which recovery cannot be performed with the check function. (P.4-29)

## Check the print condition for which nozzle recovery cannot be performed

Depending on the registered nozzle, there is a mode on which recovery is not reflected. Check the print condition for which recovery cannot be performed.



- When there are many registered nozzles, it takes much time to display the checked result.

# 1

Select **[NOZZLE RECOVERY]** of the maintenance menu.

- (1) Press the **FUNCTION** key in LOCAL.
- (2) Press **▲▼** to select **[MAINTENANCE]** and press the **ENTER** key.
- (3) Press **▲▼** to select **[NOZZLE RECOVERY]**.
- (4) Press the **ENTER** key.

**2** Select the [CHECK] by pressing   key.

NOZZLE RECOVERY  
: CHECK

**3** Press the  key.

- The mode for which nozzle recovery is invalid is displayed.
- If there is no mode for which nozzle recovery is invalid, "NONE" is displayed.







UNRECOVERABLE COND .  
: 1200x1200 24p H

Resolution      Number of passes      Scanning speed

**4** Press  the key several times to end the setting.

## Reset the set value

**1** Select [NOZZLE RECOVERY] of the maintenance menu.



- (1) Press the  key in LOCAL.
- (2) Press   to select [MAINTENANCE] and press the  key.
- (3) Press   to select [NOZZLE RECOVERY].
- (4) Press the  key.

**2** Select the [RESET] by pressing   key.

NOZZLE RECOVERY  
: RESET

**3** Press the  key.

SELECT RESET NOZZLE  
: H1 - A

**4** Select the Nozzle line that needs clear the setting value by pressing   key. Then press  key.

SELECT RESET NOZZLE  
: H1 - A



H1 - A RESET  
EXECUTE [ENT]

**5** Press the  key.

**6** Press  the key several times to end the setting.

# Automatic Maintenance Function

To use this machine comfortably, you can set various maintenances to be performed automatically. Here, set performing intervals of various automatic maintenances. You can prevent troubles such as ink clogging by performing automatic maintenance periodically (automatic maintenance function).

For the auto maintenance functions, the following items can be set:

- Important!** • When you perform maintenance manually, after manual maintenance is completed and when time set with the automatic maintenance function has passed, maintenance starts automatically.

Function name	Descriptions
REFRESH	The interval between each refreshing operation is set.
CLEANING	The interval between each cleaning operation is set.
DISWAY WASH	The interval between each disway wash operation is set.

- Important!** • During the right message is displayed, the operation set in the auto maintenance function is not carried out. Perform the operations of P.4-35 if required.
- When the power switch on the front of the machine is turned off, check the waste ink tank.

< LOCAL >  
Check waste ink [MNT]

## Setting the Refreshing Intervals

The interval between each operation of ejecting a small amount of ink from the nozzles to prevent nozzle clogging is set.

### 1 Select [AUTO MAINT.] of the maintenance menu.

- (1) Press the **FUNCTION** key in LOCAL.
- (2) Press **▲** **▼** to select [MAINTENANCE] and press the **ENTER** key.
- (3) Press **▲** **▼** to select [AUTO MAINT.].

### 2 Press the **ENTER** key.

AUTO MAINT.  
REFRESH [ENT]

### 3 Press the **ENTER** key.

REFRESH  
: Lv. 1

### 4 Press **▲** **▼** to set the refreshing interval.

- Set value : Lv.1, Lv.2, Lv.3
- As the LEVEL increases, the interval between each operation gets shorter.

REFRESH .  
: Lv. 1

### 5 Press the **ENTER** key.

AUTO MAINT.  
REFRESH [ENT]

### 6 Press **END** the key several times to end the setting.

- Important!** • Regardless of this setting, the refresh operation is performed at intervals of ten minutes to keep the pressure inside the sub-tank normally for two hours after turning off the power supply.

## Setting the Cleaning Intervals

The cleaning type and the interval between each cleaning operation are set.

**1**

Select [AUTO MAINT.] of the maintenance menu.

- (1) Press the **FUNCTION** key in LOCAL.
- (2) Press **▲** **▼** to select [MAINTENANCE] and press the **ENTER** key.
- (3) Press **▲** **▼** to select [AUTO MAINT.].
- (4) Press the **ENTER** key.

**2**

Press **▲** **▼** to select [CLEANING].

AUTO MAINT.  
CLEANING [ENT]

**3**

Press the **ENTER** key.

CLEANING  
: Lv. 1

**4**

Press **▲** **▼** to set the interval between each cleaning operation.

- Set value : Lv.1, Lv.2, Lv.3
- As the LEVEL increases, the interval between each operation gets shorter.

CLEANING  
: Lv. 1

**5**

Press the **ENTER** key.

- The cleaning type selection screen appears.

TYPE  
: NORMAL

**6**

Press **▲** **▼** to select a cleaning type.

- Set value : NORMAL, SOFT, HARD

TYPE  
: SOFT

**7**

Press the **ENTER** key.

AUTO MAINT.  
CLEANING [ENT]

**8**

Press the **END** key several times to end the setting.

## Setting the Disway wash Intervals

Set the interval for cleaning the ink discharge path in order to prevent the path from getting blocked.

# 1

Select [AUTO MAINT.] of the maintenance menu.

- (1) Press the **FUNCTION** key in LOCAL.
- (2) Press **▲** **▼** to select [MAINTENANCE] and press the **ENTER** key.
- (3) Press **▲** **▼** to select [AUTO MAINT.].

# 2

Press **▲** **▼** to select [DISWAY WASH].

```
AUTO MAINT.
DISWAY WASH [ENT]
```

# 3

Press the **ENTER** key.

```
DISWAY WASH
= OFF
```

# 4

Press **▲** **▼** to set the cleaning interval.

- Set value : OFF, 1 to 168 h

```
DISWAY WASH
= 15h
```

# 5

Press the **ENTER** key.

```
AUTO MAINT.
DISWAY WASH [ENT]
```

# 6

Press **END** the key several times to end the setting.

# Replacing consumables

## Replacing the wiper

The wiper is consumable. When the display indicates that it is necessary to replace the wiper, immediately replace the wiper with a new one. Also, wipe ink sticking to the lower surface of the slider off.

<LOCAL>  
Replace a WIPER[MNT]

**Important!**

- A cleaning wiper is an option. Buy one through the dealer in your region or at our service office.
- When you replace it before the message is displayed, first perform carriage out and then replace it. (☞ P.4-6Steps 1 to 2)  
After replacing, reset the counter for the number of times the wiper was used. (☞ P.3-38)

**1**

Press the **MAINT.** key in LOCAL.

REPLACE WIPER  
EXECUTE [ENT]

**2**

Press the **ENTER** key.

- The carriage moves to the maintenance position.

REPLACE WIPER  
COMPLETED [ENT]

**Important!**

- Until the replacement work is completed, [COMPLETED: ent] is displayed on the screen. After the work up to the Step 4 is completed and you close the right maintenance cover, press the **ENTER** key.

**3**

Open the right maintenance cover then remove the wiper.

- Pull out the wiper by holding the protrusions at its both ends.

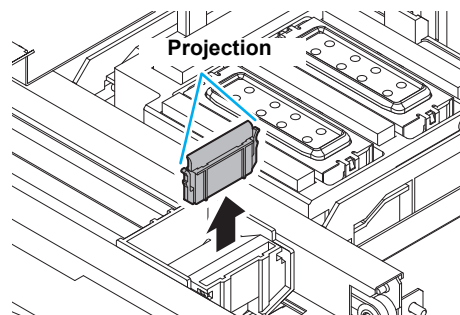

**4**

Insert a new wiper.

- Insert a new wiper by holding its both ends.

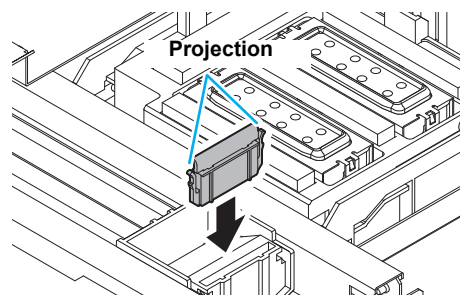

**5**

Close the right maintenance cover then press the **ENTER** key.

- After its initial operation, the machine returns to LOCAL.

Close a cover



\*Being Initialized\*  
PLEASE WAIT



## If a Waste Ink Tank Confirmation Message Appears

Ink used in head cleaning, etc. is stored in the waste ink tank on the lower right side of the machine. This machine counts the accumulated amount of discharged ink. When that reaches a specified amount, the machine displays a confirmation message. (When this message is displayed, consider the replacement of the waste ink tank.)



- The message "Check waste ink" is displayed when it reaches 80% (1.6L) of the 2L tank.
- With firmware var.3.50 or later, the message "WASTE INK FULL" appears when the tank reaches 100% (2.0L).

### Confirmation Message in LOCAL





# 1

The message on the right is displayed.

```
<LOCAL>
Check waste ink[MNT]
```

# 2

Check the state of the waste ink tank

- When it is different from the actual amount, press   and correct.
- When you correct (80%), press the  key to return to LOCAL.
- When you replace (disposal) and clear the count, perform the procedures in "Replace the waste ink tank with another". ( P.4-36)

```
Confirm a waste tank
Level: 80%(1.6L)
```

**Important!**

- Check the waste ink level in the waste ink tank frequently. Continuing to use the product without disposing of the waste ink may result in waste ink overflowing from the waste ink tank.

## Replace the waste ink tank with another

**1** The message on the right is displayed.

<LOCAL>  
Check waste ink [MNT]

**2** Press the **MAINT.** key and check the state of the waste ink tank

Confirm a waste tank  
Level: 80%(1.6L)

**3** Press the waste ink tank guard downward to open to the front.

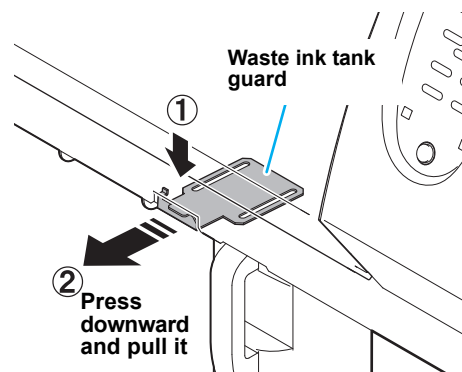

**4** Pull it forward to remove by holding the waste ink tank handle.

- Put a cap on the waste ink tank removed.

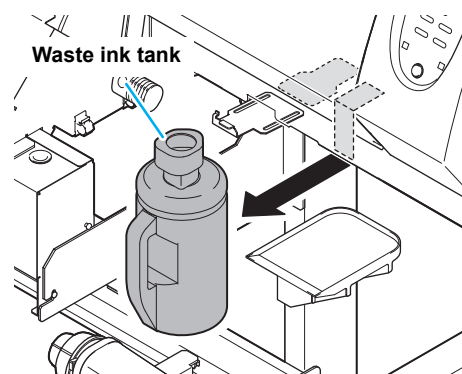
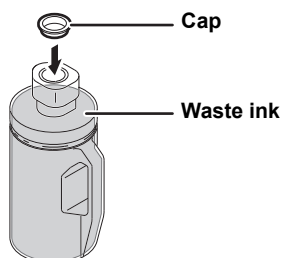

**5** Replace the waste ink tank.

- (1) Prepare a new waste ink tank (SPC-0117).
- (2) Insert the waste ink tank by holding a handle of the tank.



- Waste ink is equivalent to waste oil of industrial waste. Request an industrial waste disposal company for disposal of waste ink.

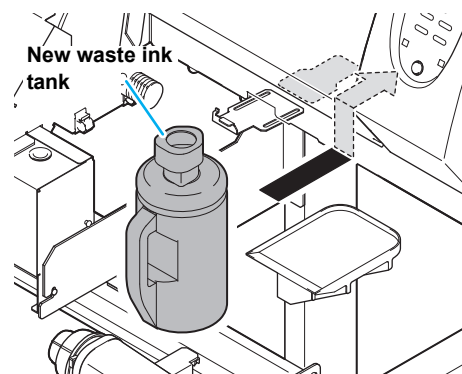

**6**

Close the waste ink tank guard.

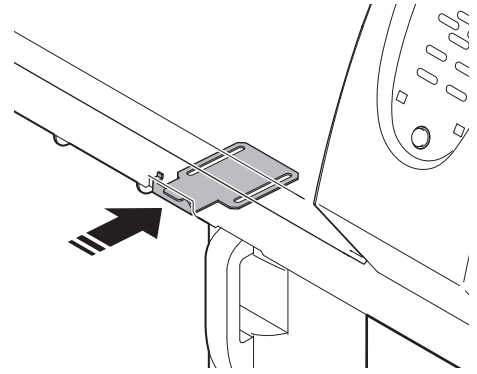

**7**

Press the **ENTER** key.

- The ink discharging amount that is controlled by the machine is reset and the message is cancelled.

COUNT CLEAR	[MNT]
EXECUTE	

## Replacing the waste ink tank before the waste ink tank confirmation message is displayed

if you replace the waste ink tank before the waste ink tank confirmation message is displayed (before the 2L tank is 80% (1.6L) full), set the waste ink information to 0% in the Information menu.

**1** Perform steps 3 through 6 in "Replace the waste ink tank with another" (☞ P.4-36) to empty the waste ink tank.

**2** Press the **FUNCTION** key in LOCAL.

FUNCTION  
SETUP [ENT]

**3** Press **▲** **▼** to select [INFORMATION].

FUNCTION  
INFORMATION [ENT]

**4** Press the **ENTER** key.

INFORMATION  
USAGE [ENT]

**5** Press **▲** **▼** to select [USAGE].

**6** Press the **ENTER** key several times until the waste ink tank information is displayed.

WASTE INK TANK  
= 60%

**7** Press the **MAINT.** key.

Confirm a waste tank  
Level: 60%(1.2L)

**8** Press **▲** **▼** to set the level "0%".

Confirm a waste tank  
Level: 0%(0.0L)

**9** Press the **ENTER** key.

## Replacing the Cutter Blade

The cutter blade is consumable. When the cutter blade gets dull, replace it with a new one (SPA-0107).



- The blade is sharp. Be careful not to hurt yourself or anyone else.
- Store the cutter blade in a place that is out of the reach of children. In addition, dispose of used cutter blades according to regional laws and regulations.



- When replacing the cutter blade, it is recommended to place a sheet of paper under the cutter blade. This will help pick up the cutter blade if it drops.

1

Press the **MAINT.** key in LOCAL.

CARRIAGE OUT  
[ ENT ]

2

Press the **ENTER** key.

MOVE POSITION  
: STATION MAINT.

3

Press **▲** **▼** to select [STATION MAINT.].

MOVE POSITION  
: STATION MAINT.

4

Press the **ENTER** key.

- The carriage moves to the maintenance position.

5

Open the right maintenance cover.

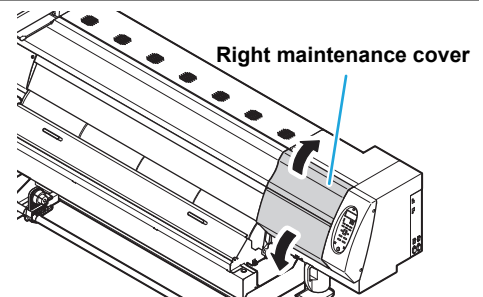

4

---

**6****Replace the cutter unit by the carriage.**

- (1) Loosen the screw of the cutter unit.
- (2) Remove the cutter unit.
- (3) Mount a new cutter unit.
- (4) Fasten the screw of the cutter unit to secure the cutter unit.

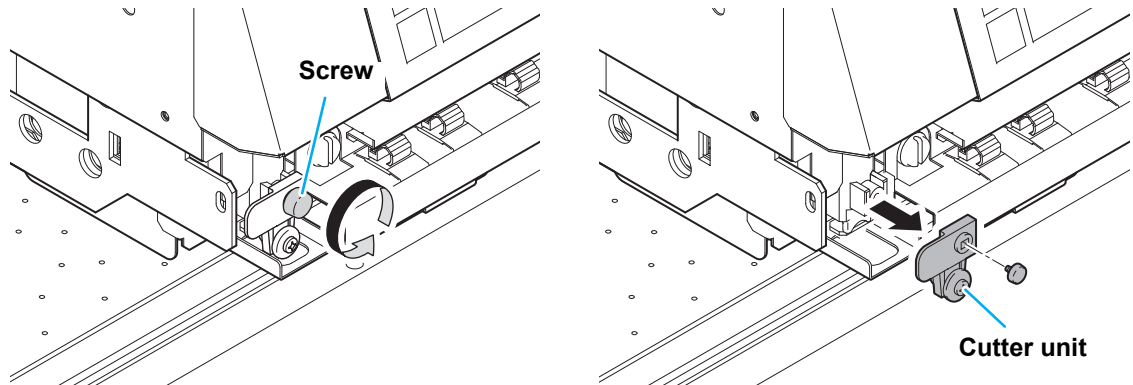
**7****Close the right maintenance cover.****8****Press the **ENTER** key.**

- The screen returns to step1.
-

## Checking UV ink curing level

Deteriorating of the UV lamp may lower the ink curing level.  
Check the ink curing level and adjust the UV lamp light intensity as needed.

**1**

### Set a media for drawing pattern.

- use mimaki Genuine media (White PVC: SPC-0706).

**2**

### Select [UV CURING CHECK] of the maintenance menu.

- (1) Press the **FUNCTION** key in LOCAL.
- (2) Press **▲** **▼** to select [MAINTENANCE] and press the **ENTER** key.
- (3) Press **▲** **▼** to select [UV CURING CHECK].

**3**

### Press the **ENTER** key.

RESOLUTION  
: 1200x900

**4**

### Press **▲** **▼** to select [RESOLUTION].

- Setting value : 1200 x 1200 dpi, 1200 x 900 dpi  
900 x 1200 dpi, 900 x 900 dpi

RESOLUTION  
: 1200x900

**5**

### Check the state of the waste ink tank

PASS  
: 12

**6**

### Press **▲** **▼** to select pass.

- Setting value : Pass depending on resolution

PASS  
: 12

**7**

### Check the state of the waste ink tank

DIR. / SPEED  
: Bi / Hi .

**8**

### Press **▲** **▼** to select direction/speed.

- Setting value : Bi / Hi, Uni / Hi,  
Bi / Std, Uni / Std

DIR. / SPEED  
: Bi / Hi .

**9**

### Check the state of the waste ink tank

UV CURING CHECK  
PRINT [ENT]

## 10 Check the state of the waste ink tank

\*\* PRINTING \*\*  
PLEASE WAIT

- Test drawing starts.

**Important!**

- If the temperature of the UV lamp has not reached the predetermined value, a message appears. In this case, it is not drawn. When the display disappears, drawing can be started.
- If you open the shading cover while the UV lamp lights, the UV lamp is turned off. However, the operation will continue.

## 11 Press the **END** key several times to end the setting.

## 12 Check the drawing pattern after the test drawing.

- Rub print surface with the cotton swab saturated with cleaning liquid 10 strokes.
- Check the change of the surface by visual inspection.  
When the print surface is peeled off, UV light intensity is weakened.  
When any change is not found, there is no problem on UV lights.
- If the UV light intensity is weak, the rub fastness is significantly reduced.

**Important!**

- When UV light intensity is weakened, UV lamps are weakened. If the UV ink curing level is not improved after adjusting the UV light intensity, the UV LED is deteriorated. Contact your local distributor, our sales office, or service center.

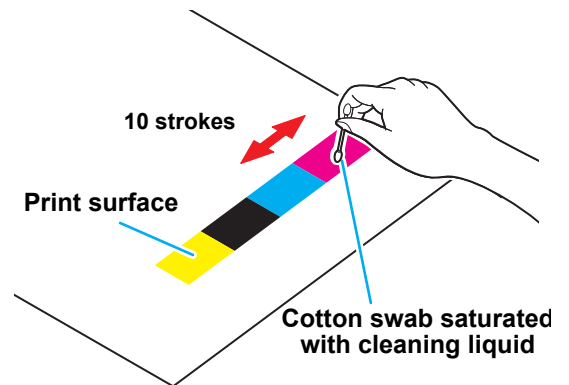



# Chapter 5

## Troubleshooting



### This chapter

describes the corrective measures to be taken for a phenomenon suspected to be trouble and the procedures to clear the error number displayed on the LCD.

Troubleshooting .....	5-2
Power does not turn on .....	5-2
The machine does not start printing .....	5-2
Media get jammed / media is soiled .....	5-3
[HEAT] or [CONSTANT] LED does not light up .....	5-3
Image quality is poor .....	5-4
Nozzle is clogged .....	5-4
Ink cartridge warning appears .....	5-5
“Check Ink Pack” appears .....	5-6
When the INK REMAIN Setting Message is Displayed .....	5-7
When Error 618 to 61b occur .....	5-8
If negative pressure abnormality occurs .....	5-9
When media heaves up at feeding .....	5-11
When the feeding media is loosened and reached to the floor .....	5-11
Warning / Error Messages .....	5-12
Warning messages .....	5-12
Error messages .....	5-15

# Troubleshooting

Take appropriate actions as described below before taking the trouble as a failure.

If still the problem is not solved after troubleshooting, contact your local distributor, our sales office, or service center.

## Power does not turn on

In most cases, this is due to improper connection of the power cable for the machine or computer. Check that the power cable is connected properly.

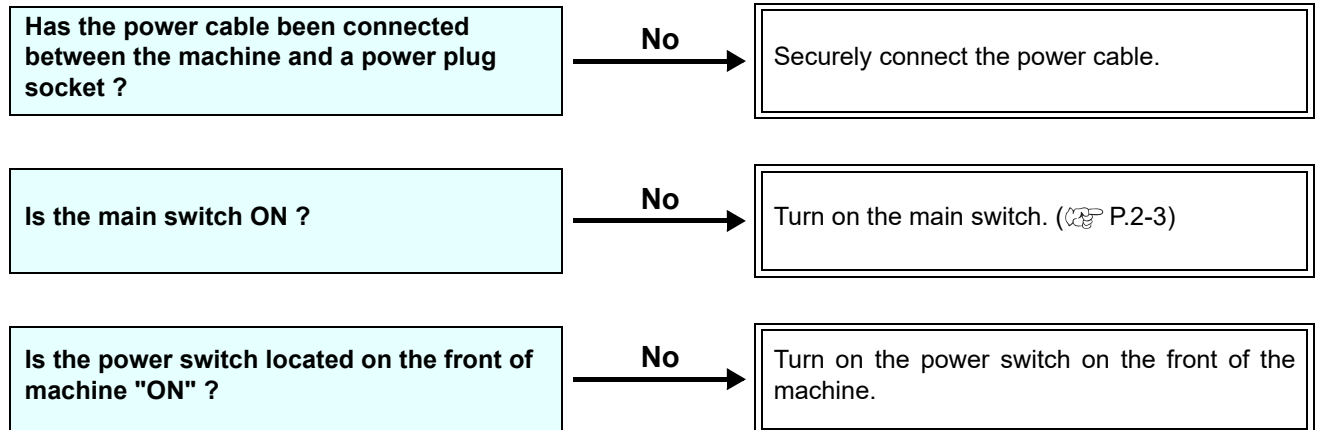

## The machine does not start printing

This occurs when the data is not being transmitted to the machine properly.

It can also occur when the printing function does not work properly or the media is not set correctly.

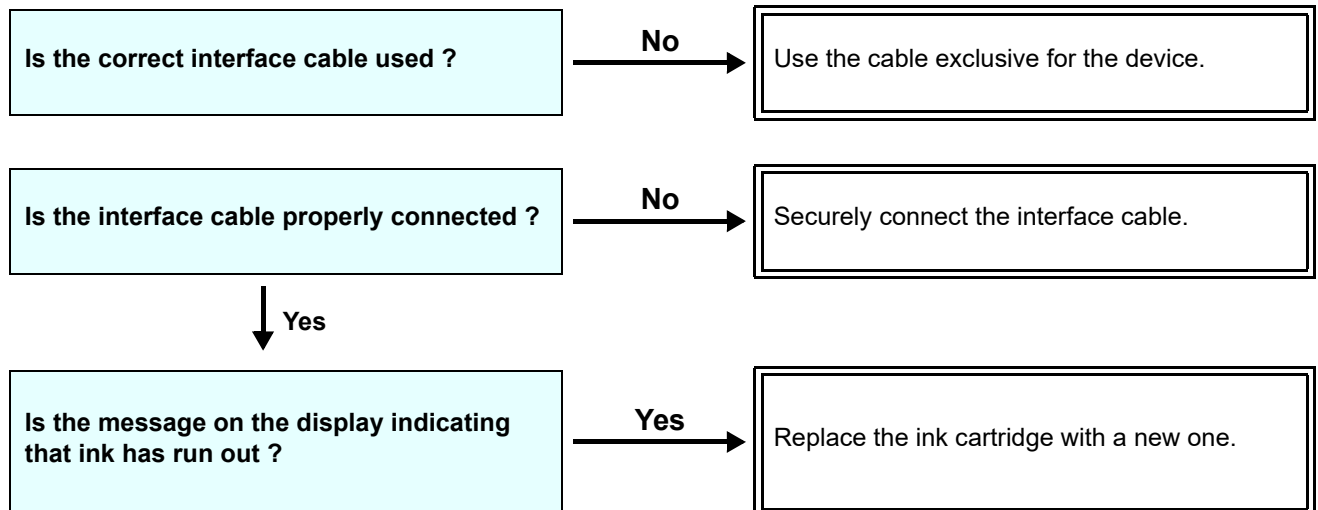

### Media get jammed / media is soiled

Media jamming or stained media is considered to be due to the use of an unsuitable media or improper setting of media.

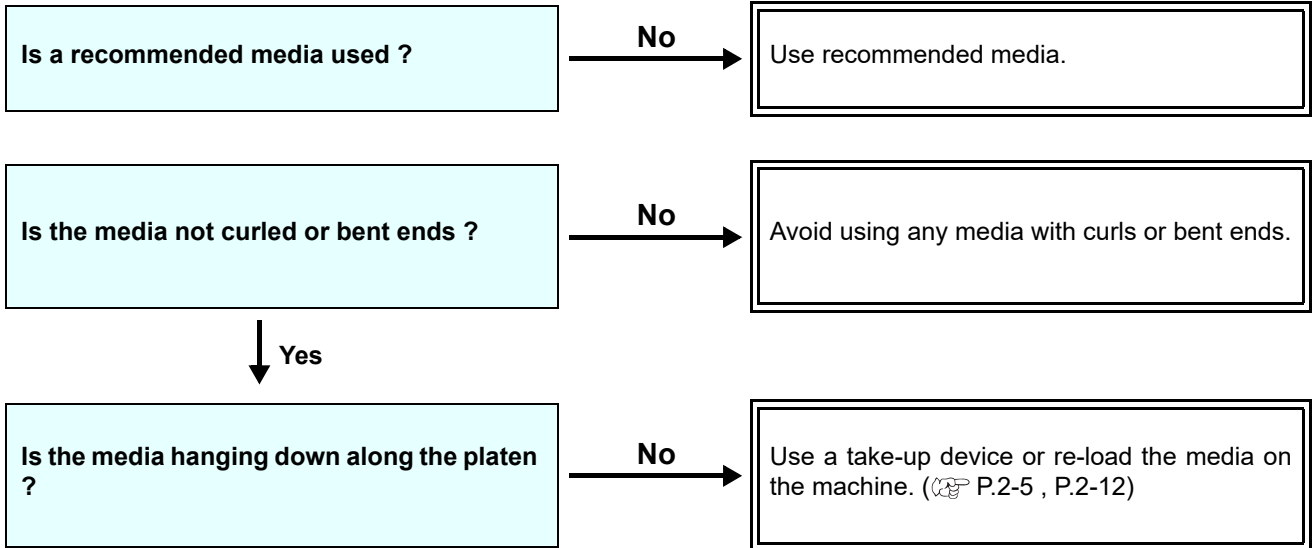

### [HEAT] or [CONSTANT] LED does not light up

Check the basic operation.

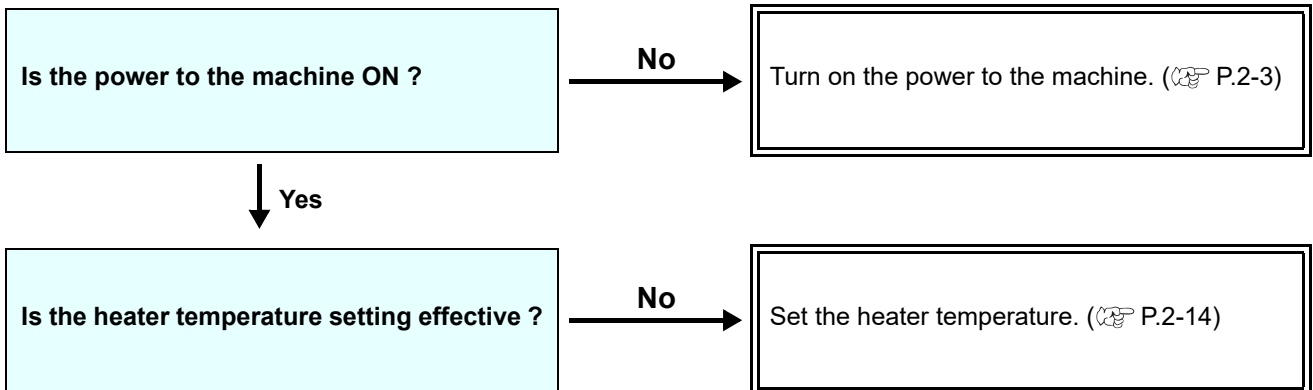

## Image quality is poor

This section describes the corrective actions to be taken in case the image quality is not satisfactory. Take remedy for particular problems with image quality. If the remedy does not work, contact your local distributor, our sales office, or service center.

Phenomenon	Measures
White lines / blur / dark stripes (in the direction of travel of the heads)	<ol style="list-style-type: none"> <li>(1) Execute the head cleaning. (☞ P.2-19)</li> <li>(2) Perform maintenance of the inside of the station. (☞ P.4-6)</li> <li>(3) Execute the [MEDIA COMP.] function. (☞ P.2-20)</li> <li>(4) If any pieces of paper or dust is attached on the path of the heads such as media press, remove it.</li> </ol>
Characters are double- or triple-printed in the media feed direction	<ol style="list-style-type: none"> <li>(1) Execute the [MEDIA COMP.] function. (☞ P.2-20)</li> </ol>
Disagreement in print positions between outward trip and homeward trip	<ol style="list-style-type: none"> <li>(1) Execute the [DROP POSITION] function. (☞ P.2-22)</li> </ol>
Ink drops falling on media during printing	<ol style="list-style-type: none"> <li>(1) Execute the wiper cleaning. (☞ P.4-6)</li> <li>(2) Execute the ink cap cleaning. (☞ P.4-6)</li> <li>(3) Clean around the head. (☞ P.4-19)</li> <li>(4) Execute the head cleaning [NORMAL]. (☞ P.2-19)</li> <li>(5) Set a shorter interval of INTERVAL WIPING operation. (☞ P.3-9)</li> </ol>

## Nozzle is clogged

When nozzle clogging is not dissolved even after the head cleaning referring to P.2-19, make sure the following operations.

- Wash the head nozzle by the operations of P.4-23.
- Recovery the nozzle by the operations of P.4-28.

## Ink cartridge warning appears

If an ink cartridge trouble is detected, the cartridge LED “red” is lit, and a warning message appears. None of printing, cleaning and all the other operations that use ink is available. In this case, replace the ink cartridge in question immediately.

**Important!**

- Once cartridge trouble is displayed, do not leave the ink cartridge without replacing it for a long time; otherwise, the machine will lose the nozzle clogging prevention function. If nozzles are clogged, the machine must be repaired by MIMAKI's service engineer.

### Displaying the description of ink cartridge trouble

The contents of cartridge error are confirmable by the following operations.

**1**

Press the **ENTER** key in LOCAL.

SU100	MMCCYYKK
REMAIN	34567899

**2**

Press the **ENTER** key.

INK iC CAN'T READ
MMCCYYKK

- When multiple cartridge defects occur and if you press the **ENTER** key or **◀▶**, they are displayed by turns.

## “Check Ink Pack” appears

If you are using an eco cartridge and if there is a problem with the ink pack, the cartridge light turns red and a warning message appears.

All operations related to the ink supply are disabled.

Check whether there is any ink left inside the ink pack as soon as possible.

**1** Press the **END** key several times to return to LOCAL.

**2** Pull out the cartridge where the message “Check Ink Pack” has appeared.

- Pull out the cartridge with the red light on the ink station.

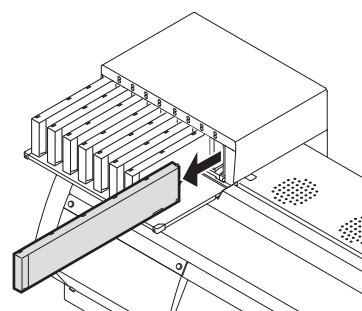

**3** Check whether there is any ink left inside the ink pack.

- Open the eco cartridge lid (refer to step 1 in P.1-16 “How to assemble ink cartridge” )  
(1) Check the ink pack.  
(2) Return the ink pack to its original state and close the eco cartridge lid.

**4** Return the eco cartridge that you checked in step 3 to the original ink slot.

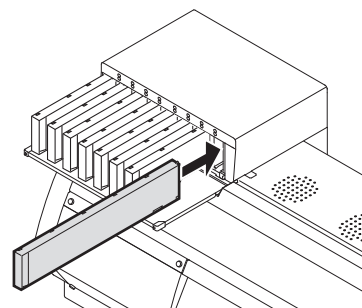

- If you are using firmware var.3.50 or later, the screen to the right appears on the display. Carry out one of the following operations depending on the ink pack state.

Ink Remainig? : 1  
NO < > YES

**If there is ink left inside the ink pack :**

Press the **▶** key and select “YES”.

**If there is no ink left inside the ink pack :**

Press the **◀** key, select “NO”, and then press the **ENTER** key.



**If your firmware version is 3.30 or earlier.**

- “CHECK INK PACK” is canceled and the cartridge is ready to be used.



**If you press the **▶** key and then select “YES”**

- You can continue using the original eco cartridge.

**If you press the **◀** key and then select “NO”**

- If you press the **ENTER** key, the eco cartridge status changes to “INK END”. Refer to P.1-12 “Changing an ink cartridge” and replace the ink pack and the IC chip.

## When the INK REMAIN Setting Message is Displayed

If the remaining amount of ink inside the cartridge falls below a specified level when [SET UP] in INK REMAIN of MACHINE SETUP is set to "ON" (☞ P.3-17), a warning message appears on the display. When the message appears, perform the following steps to adjust the ink cartridge weight. Please prepare your scale (which can weigh up to 1200g in 1g).

### 1 Press the **MAINT.** key in LOCAL.

- The slot with the ink cartridge for which you need to register the weight is selected automatically.

SLOT 1  
INK REMAIN =800g

### 2 Weigh the ink cartridge on the scale.

- Attach the IC chip and the ink pack when weighing.

### 3 Press **▲** **▼** to enter the weight of cartridge checked at the Step 2.

SLOT 1  
INK REMAIN =800g

### 4 Press the **ENTER** key.

SLOT 1  
800g OK? [ENT]

### 5 Check the weight and press the **ENTER** key.

- If there are other slots for which the weight registration is necessary, each slot is automatically numbered. Repeat steps 2 to 4.
- If there are no more slots where the weight registration is necessary, you will automatically return to LOCAL.

## When Error 618 to 61b occur

Error 618 to 61b are errors related to the subtank.

Execute following procedures when an error about subtank occurs, or when the nozzle is not unclogged after cleaning.

**1**

Select [SUB TANK] of the maintenance menu.

- (1) Press the **FUNCTION** key in LOCAL.
- (2) Press **▲▼** to select [MAINTENANCE] and press the **ENTER** key.
- (3) Press **▲▼** to select [SUB TANK].

**2**

Press the **ENTER** key.

```
SELECT SUBTANK
: MMCCYYKK
```

**3**

Select the subtank to maintenance.

- Select the subtank with the **◀▶** key.
- If Error 61b occurs, an appropriate head is selected. Press **ENTER** key.

```
SELECT SUBTANK
: MMCC_----
```

**4**

Press the **ENTER** key.

```
SUB TANK
EXECUTE [ENT]
```

**5**

Press the **ENTER** key.

- The automatic discharging operation and the filling operation are performed.
- Then, cleaning is performed.

```
** FILLING **
PLEASE WAIT
```

```
** CLEANING **
PLEASE WAIT
```

**6**

Press **END** the key several times to end the setting.

**Important!**

- If "Error 61a" has occurred during printing or waiting, "SUBTANK" of the MAINTENANCE MENU is performed automatically.



## If negative pressure abnormality occurs

By the environment or aging, the pressure controlled in this machine may exceed the control range. If an error related to pressure abnormality occurs, perform the procedures below:

**Important!**

- When error display of (1) appears, immediately adjust the pressure as the following procedures to reset to the normal value.

**1**

Select [PRESSURE ADJUST] of the maintenance menu.

- (1) Press the **FUNCTION** key.
- (2) Press **▲** **▼** to select [MAINTENANCE] and press the **ENTER** key.
- (3) Press **▲** **▼** to select [PRESSURE ADJUST].

**2**

Press **▲** **▼** to select **POSITIVE/NEGATIVE**.

PRESSURE ADJUST  
: NEGATIVE

**3**

Press the **ENTER** key.

Open Throttle Valve  
COMPLETED [ENT]

**4**

Rotate the adjustment screw of the throttle valve to release it so that air can flow.

- The throttle valve is located on the back side of the left side cover. Rotate it until the adjustment screw of the throttle valve comes to the middle position.

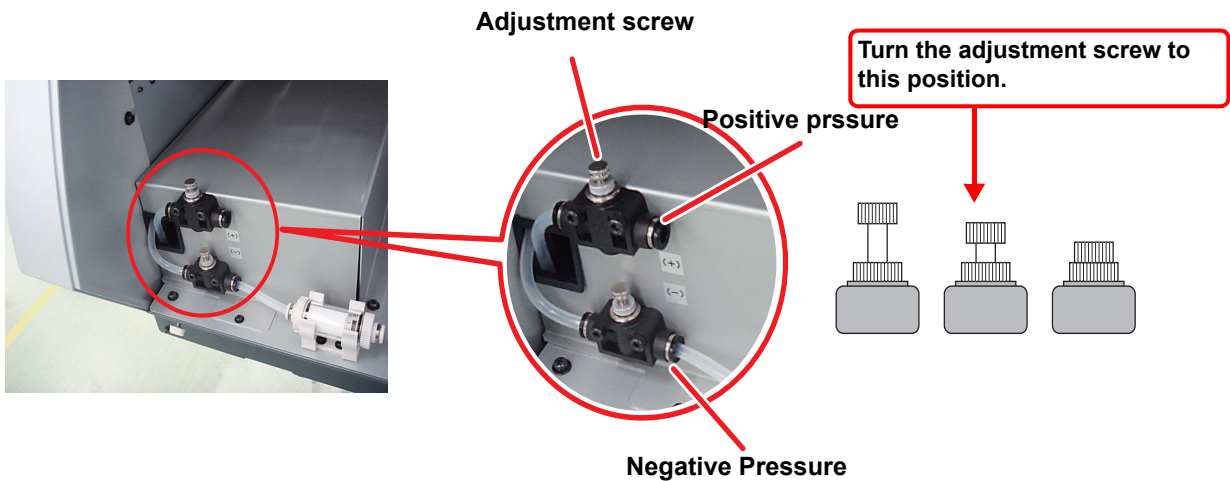

**5**

Press the **ENTER** key.

- Sensor adjustment starts.

\*\* ADJUSTING \*\*  
PLEASE WAIT

# 6

Rotate the adjustment screw of the throttle valve to adjust the pressure so that it becomes the proper value.

PRESSURE  
= - 1.90 kPa

- Proper value of negative pressure: -1.90kPa  
Proper value of positive pressure: 15.00kPa
- As the negative pressure changes between  $\pm 0.1$  and 0.2kPa, adjust so that the intermediate value may become the target pressure.  
As the positive pressure changes between  $\pm 1.0$  and 2.0kPa, adjust so that the intermediate value may become the target pressure.



- Pressure is informed with the buzzer and the ink cartridge LED as well as the screen display.
- For the negative pressure, the buzzer stops within the range of  $\pm 0.1$ kPa. For the positive pressure, the buzzer stops within the range of  $\pm 1.0$ kPa.

- Status of lamp and buzzer for each pressure value

	Pressure		Cartridge LED	Buzzer
	Positive pressure	Negative pressure		
High	~ 8.49	~ -1.16	●○○○○○○○ ○○○○○○○○○	Sounds
	8.50 ~ 9.49	-1.26 ~ -1.35	●●○○○○○○○ ○○○○○○○○○	
	9.50 ~ 10.49	-1.36 ~ -1.45	●●●○○○○○○○ ○○○○○○○○○	
	10.50 ~ 11.49	-1.46 ~ -1.55	●●●●○○○○○○○ ○○○○○○○○○	
	11.50 ~ 12.49	-1.56 ~ -1.65	●●●●●○○○○○○○ ○○○○○○○○○	
	12.50 ~ 13.49	-1.66 ~ -1.75	●●●●●●○○○○○○○ ○○○○○○○○○	
	13.50 ~ 14.49	-1.76 ~ -1.85	●●●●●●●○○○○○○○ ○○○○○○○○○	Stops
Proper value	14.50 ~ 15.49	-1.86 ~ -1.95	●●●●●●●●○○○○○○○ ○○○○○○○○○	Stops
Low	15.50 ~ 16.49	-1.96 ~ -2.05	●●●●●●●●●○○○○○○○ ●○○○○○○○○○	Stops
	16.50 ~ 17.49	-2.06 ~ -2.15	●●●●●●●●●●○○○○○○○ ●●○○○○○○○○○	Sounds
	17.50 ~ 18.49	-2.16 ~ -2.25	●●●●●●●●●●●○○○○○○○ ●●○○○○○○○○○	
	18.50 ~ 19.49	-2.26 ~ -2.35	●●●●●●●●●●●●○○○○○○○ ●●●○○○○○○○○○	
	19.50 ~ 20.49	-2.36 ~ -2.45	●●●●●●●●●●●●●○○○○○○○ ●●●●○○○○○○○○○	
	20.50 ~ 21.49	-2.46 ~ -2.55	●●●●●●●●●●●●●●○○○○○○○ ●●●●●○○○○○○○○○	
	21.50 ~ 22.49	-2.56 ~ -2.65	●●●●●●●●●●●●●●●○○○○○○○ ●●●●●●○○○○○○○○○	
	22.50 ~	-2.66 ~	●●●●●●●●●●●●●●●●○○○○○○○ ●●●●●●●○○○○○○○○○	

# 7

Press the **ENTER** key.

PLEASE WAIT

- The error is released and the pressure control starts.



- When an error occurs even after you adjusted the pressure, contact your local distributor, our sales office, or service center.

## When media heaves up at feeding

We call the status of heaving media at feeding “cockling”.  
When media cockling occurs, check the following items:

Note/ checking items	Measures
<b>Checking media set status</b>	(1) Check that the media is set straight and reset it.
<b>Adjusting heater temperature</b>	(1) Raise the pre-heater temperature by 5 to 10 degrees. (2) Lower all heaters' temperatures. (When you lower the heater temperature, drying time may not be enough. Lower the FEED SPEED.)
<b>Media feeding</b>	(1) For roll media, feed the media by about tens of centimeters to one meter.
<b>Do not leave the media in the heater warming status</b>	(1) Do not start printing with the media cockled because it may cause media jam.
<b>Heighten the head</b>	(1) For the thick media, heighten the head from L to M before printing.

## When the feeding media is loosened and reached to the floor

The feeding roll media is loosened and reached to the floor if the holder is not properly pressed against the core of the roll media while the roll media is set to the roll holder on the back side of the printer. when the feeding media is loosened, please take following measures. Loosen the screw of the right side roll holder and firmly press the holder against the core of the roll paper and then tighten the screw. (The indication of pressing power: 15 kgf ) (☞ P.2-9)

Please note that the feeding media is more often loosened under conditions described below.

- After printing, when the media is moved backwards against the feeding direction.
- When the heavy roll media like the banner material (tarpaulin) is used.
- When a remaining length of the roll media reaches low during printing. Or when the remaining length of set media is already low.

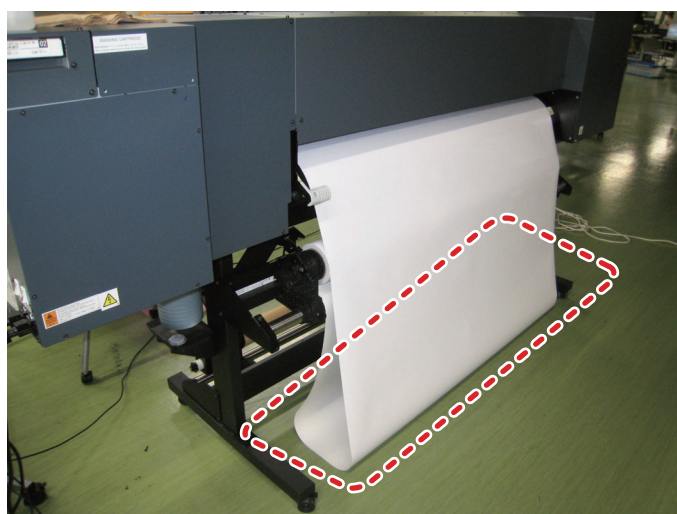

# Warning / Error Messages

If some trouble occurs, the buzzer sounds and the display shows a corresponding error message. Take an appropriate remedy for the displayed error.

## Warning messages

### Errors when performing operations

Message	Cause	Solution
CAN'T OPERATE COVER OPEN	The front cover or the maintenance cover is opened.	<ul style="list-style-type: none"> <li>Check the front cover and maintenance covers.</li> <li>If the same error message appears again even after closing all the covers, contact your local distributor to call for service.</li> </ul>
CAN'T OPERATE MEDIA UNDETECTED	The media has not been detected.	<ul style="list-style-type: none"> <li>Perform media detection.</li> </ul>
CAN'T OPERATE (MOTOR OFF)	The motor is OFF after the cover was opened etc.	<ul style="list-style-type: none"> <li>Close the front cover and maintenance covers.</li> </ul>
CAN'T OPERATE INK ERROR	An ink error occurred.	<ul style="list-style-type: none"> <li>Check the cartridge for the supply path corresponding to the indicated color.</li> </ul>
CAN'T OPERATE DATA REMAIN	Data was received.	<ul style="list-style-type: none"> <li>Perform data clear. (☞ P.2-26)</li> </ul>
CAN'T OPERATE (CLAMP LEVER OFF)	The clamp lever is raised.	<ul style="list-style-type: none"> <li>Lower the clamp lever and detect the media.</li> </ul>

### Message displayed in LOCAL

Message	Cause	Solution
<LOCAL> Can't PRINT / CART. [ENT]	Ink errors (unusable ink) occur in multiple cartridges. Ink supply (print, cleaning, etc.) cannot be performed.	<ul style="list-style-type: none"> <li>Press the <b>ENTER</b> key to check the cartridge generating the warning.</li> <li>Replace them with usable cartridges.</li> </ul>
<LOCAL> Check waste ink [MNT]	The waste ink tank is nearly full.	<ul style="list-style-type: none"> <li>Check the waste ink tank.</li> <li>Press the <b>MAINT.</b> key to correct or reset the counter. (☞ P.4-35)</li> </ul>
<LOCAL> WASTE INK FULL [MNT]	The waste ink tank is full.	
<LOCAL> Replace a WIPER [MNT]	Time to replace the wiper in the capping station with a new one has come. (The wiping count has reached the specified value.)	<ul style="list-style-type: none"> <li>Press the <b>MAINT.</b> key and replace the wiper with a new one. (☞ P.4-34)</li> </ul>
<LOCAL> Cleaning WIPER [MNT]	Time to clean the wiper in the capping station with a new one has come. (The wiping count has reached the specified value.)	<ul style="list-style-type: none"> <li>Press the <b>MAINT.</b> key and clean the wiper. (☞ P.4-6)</li> </ul>
<LOCAL> INK REMAIN [MNT]	The remaining amount of ink inside the cartridge falls below the specified level.	<ul style="list-style-type: none"> <li>Press the key and register the cartridge weight. (☞ P.5-7)</li> </ul>
<LOCAL> ** NO MEDIA **	The media is not set. The sensor has been broken.	<ul style="list-style-type: none"> <li>Set the media. (☞ P.2-5) If the same error message appears again, contact your local distributor to call for service.</li> </ul>

Message	Cause	Solution
<LOCAL> DATA REMAIN	The data has been received.	• Press the <b>REMOTE</b> key to perform printing. Or, perform data clear.
<LOCAL> NEGATIVE PRESSURE	The value of the negative pressure sensor is abnormal.	• Perform "PRESSURE ADJUST (P.5-9)" of the maintenance. If you cannot adjust it to the normal value, or, even if you perform, it may be displayed, contact your local distributor to call for service.
<LOCAL> POSITIVE PRESSURE	The value of the positive pressure sensor is abnormal.	
<LOCAL> INK NEAR END [ENT]	The ink of the ink cartridge has been nearly used up.	• Press the <b>ENTER</b> key to check the relevant cartridge. Be careful because it may be INK NEAR END soon.
<LOCAL> SUPPLY INK :MMCCYYKK	Ink could not be supplied to the sub tank.	• Perform "SUB TANK (P.5-8)" of the maintenance. Also check the remaining amount of ink in the cartridge. Even if you performed this, when the message is displayed, contact your local distributor to call for service.
<LOCAL> SubtankSens :MMCCYYKK	The liquid level sensor abnormality of the sub tank has been detected.	• Turn off the power to the machine and turn it on after a while. If the same error message appears again, contact your local distributor to call for service.
<LOCAL> InkOverflow :MMCCYYKK	Overflow from the sub tank has been detected.	• Perform "SUB TANK (P.5-8)" of the maintenance. Also check the remaining amount of ink in the cartridge. Even if you performed this, when the message is displayed, contact your local distributor to call for service.
<LOCAL> TANKlevrIH :MMCCYYKK	Though a certain amount was consumed, there is no change in the sub tank sensor High.	
<LOCAL> TANKlevrIL :MMCCYYKK	Though a certain amount was consumed, there is no change in the sub tank sensor Low.	
<LOCAL> MachineTEMP/Hi ***°C	The machine temperature is high.	• Adjust the ambient temperature of the installation place.
<LOCAL> MachineTEMP/Lo ***°C	The machine temperature is low.	
<LOCAL> UV CURING CHECK	It is time to replace the UV lamp.	• Perform "UV CURING CHECK (P.4-41)" of maintenance, and check the illumination. • When ink is not sufficiently cured, contact your local distributor to call for service.
<LOCAL> UV LAMP COVER	UV lamp shading cover is opened.	• Close the cover.
HEATER TEMP ERROR POWER OFF [ENT]	After "error 710 HEATER TEMP ERROR" has occurred, the power is forcibly turned off, and when you restart it, this is displayed.	• If the ERROR 710 appears again, contact your local distributor to call for service.
<LOCAL> Expiration [ENT]	The specified expiration date of an ink cartridge has passed.	• The expiration date has passed. • However, you can use it until the end of the following month. • Press the <b>ENTER</b> key to check the cartridge generating the warning.
<LOCAL> Expiration(1M) [ENT]	The expiration date of an ink cartridge has passed (one month has passed after the specified expiration date).	• One month has passed after the expiration date. However, you can use it until the end of this month. (The red LED blinks.) • Press the <b>ENTER</b> key to check the cartridge generating the warning.

Message	Cause	Solution
<LOCAL> Expiration(2M) [ENT]	The expiration date of an ink cartridge has passed (two months have passed after the specified expiration date).	<ul style="list-style-type: none"> <li>Two months have passed after the expiration date. Replace the cartridge generating the warning with a new one.</li> <li>Press the <b>(ENTER)</b> key to check the cartridge generating the warning.</li> </ul>
MEDIA JAM	Carriage stopped because the media jam occurred.	<ul style="list-style-type: none"> <li>Open the cover, remove the media and reset. (Supported from the firmware ver.3.00)</li> </ul>
Check Jam Sensor	The jam sensor detects an error.	<ul style="list-style-type: none"> <li>Open the maintenance cover and check around the carriage.</li> </ul>
PRINTING PAUSE CONTINUE< >CANCEL	Print interrupted by the cover open or detection of media jam.	<ul style="list-style-type: none"> <li>Close the cover or eliminate the media jam. Select the action by the right or left keys.</li> </ul>

## Ink Error

Ink error is displayed also in the local guidance. (☞ P.3-41)

Message	Cause	Solution
INK IC CAN'T READ : - - - - YYKK	The IC chip of the ink cartridge cannot be read normally.	<ul style="list-style-type: none"> <li>Remove the cartridge generating the warning once and install it again.</li> <li>If the same warning message still appears, contact your local distributor to call for service.</li> </ul>
WRONG INK IC : - - - - YYKK		
KIND OF INK : - - - - YYKK	The ink of the ink cartridge is different in type from the ink currently supplied.	<ul style="list-style-type: none"> <li>Check the ink type of the cartridge generating the warning.</li> </ul>
COLOR OF INK : - - - - YYKK	The ink of the ink cartridge is different in color from the ink currently supplied.	<ul style="list-style-type: none"> <li>Check the ink color of the cartridge generating the warning.</li> </ul>
WRONG CARTRIDGE : - - - - YYKK	An error occurred in the IC chip information of the ink cartridge.	<ul style="list-style-type: none"> <li>Check the cartridge generating the warning.</li> <li>When you use white ink, check that there is no nozzle missing etc.</li> </ul>
NO CARTRIDGE : - - - - YYKK	An ink cartridge has not been installed in the slot.	<ul style="list-style-type: none"> <li>Install an appropriate cartridge in the slot generating the warning.</li> </ul>
INK END : - - - - YYKK	The ink of the ink cartridge has been completely used up.	<ul style="list-style-type: none"> <li>Replace the cartridge generating the warning with a new one.</li> </ul>
INK NEAR END : - - - - YYKK	The ink of the ink cartridge has been nearly used up.	<ul style="list-style-type: none"> <li>Replace the cartridge generating the warning with a new one.</li> </ul>
CHCK INKPACK : - - - - YYKK	Even when there are enough ink, ink end has been detected.	<ul style="list-style-type: none"> <li>Check the ink pack set status in the eco case.</li> </ul>
Expiration : - - - - YYKK	The specified expiration date of an ink cartridge has passed.	<ul style="list-style-type: none"> <li>The expiration date has passed.</li> <li>However, you can use it until the end of the following month.</li> </ul>
Expiration: 1MONTH : - - - - YYKK	The expiration date of an ink cartridge has passed (one month has passed after the specified expiration date).	<ul style="list-style-type: none"> <li>One month has passed after the expiration date.</li> <li>However, you can use it until the end of this month. (The red LED blinks.)</li> </ul>
Expiration: 2MONTH : - - - - YYKK	The expiration date of an ink cartridge has passed (two months have passed after the specified expiration date).	<ul style="list-style-type: none"> <li>Two months have passed after the expiration date. Replace the cartridge generating the warning with a new one.</li> </ul>

## Error messages

When an error message is displayed, eliminate the error according to the chart below.

If the same error message appears again, contact your dealer or an office of MIMAKI to call for service.

Message	Cause	Solution	
ERROR 108 HD CONNECT [12345678]	Head connection can not be confirmed.	<ul style="list-style-type: none"> <li>• Turn off the power to the machine and turn it on after a while.</li> <li>If the same error message appears again, contact your local distributor to call for service.</li> </ul>	
ERROR 108 HD THERMIS [12345678]	Head temperature can not be read.		
ERROR 108 HD MEM EMP [12345678]	The head memory has no data.		
ERROR 108 HD TYPE [12345678]	Solvent ink was used in the head for water.		
ERROR 12e Head Failed [xxxx]	Abnormality of the Driver of the Print head.		
ERROR 122 CHECK : SDRAM	There is no PRAM.		
ERROR 128 HDC FIFO OVER	<ul style="list-style-type: none"> <li>• Data transmission speed is too fast.</li> <li>• Control circuit board is defective.</li> </ul>		
ERROR 128 HDC FIFO UNDER	<ul style="list-style-type: none"> <li>• Data transmission speed is too slow.</li> <li>• Control circuit board is defective.</li> </ul>		
ERROR 129 BATTERY EXCHANGE	The battery life end of the internal clock is detected.		<ul style="list-style-type: none"> <li>• Contact your local distributor to call for service.</li> </ul>
ERROR 130 HD DATA SEQ	Head data transferring sequence error occurred.		<ul style="list-style-type: none"> <li>• Turn off the power to the machine and turn it on after a while.</li> <li>If the same error message appears again, contact your local distributor to call for service.</li> </ul>
ERROR 146 E-LOG SEQ	Sequential number abnormality of the event log occurred.		
ERROR 151 Main PCB V12R	An error occurred in the main PCB 1.2V power supply.		
ERROR 152 Main PCB V2R5	An error occurred in the main PCB 2.5V power supply.		
ERROR 153 Main PCB V3R3	An error occurred in the main PCB 3.3V power supply.		
ERROR 155 Main PCB V35-1	An error occurred in the main PCB 35-1 power supply.		
ERROR 157 Main PCB VTT	An error occurred in the main PCB VTT power supply.		
ERROR 158 Main PCB V352	An error occurred in the main PCB 35-2V power supply.		

Message	Cause	Solution
ERROR 16e Main PCB V3R3B	An error occurred in the main PCB 3.3VB power supply.	
ERROR15f HEAD DRIVE HOT	COM driver becomes the high temperature.	
ERROR 171 NEW HEAD CONNECT	New Print Head was recognized.	
ERROR 172 Main PCB Q6 Check K	The main PCB Q6 is disabled (short mode).	
ERROR 186 HDC OVERFLOW	An error is detected on the waveform printed on.	<ul style="list-style-type: none"> <li>• Turn off the power to the machine and turn it on after a while.</li> <li>If the same error message appears again, contact your local distributor to call for service.</li> </ul>
ERROR 186 HDC UNDERFLOW		
ERROR 187 HDC SLEW RATE		
ERROR 188 HDC MEMORY		
ERROR 18a Main PCB V_CORE	An error occurred in the main PCB V_CORE power supply.	
ERROR 18b Main PCB V1R5B	An error occurred in the main PCB 1.5VB power supply.	
ERROR 18c Main PCB V12	An error occurred in the main PCB 12V power supply.	
ERROR 201 COMMAND	The machine received some data other than command data.	<ul style="list-style-type: none"> <li>• Securely connect the interface cable in position.</li> <li>• Use an interface cable conforming to the specifications.</li> </ul>
ERROR 202 PARAMETER	Any parameter outside the range of acceptable numeric values was received.	
ERROR 304 USB INIT ERR	USB device initialization failure.	<ul style="list-style-type: none"> <li>• Turn off the main power to the machine and turn it on after a while.</li> <li>If the same error message appears again, contact your local distributor to call for service.</li> </ul>
ERROR 305 USB TIME OUT	Occurrence of a time out error on a USB device.	
ERROR 401 MOTOR X	An excessive load was applied to the X motor.	
ERROR 402 MOTOR Y	An excessive load was applied to the Y motor.	
ERROR 403 X CURRENT	An error due to an excessive current of the X motor was detected.	
ERROR 404 Y CURRENT	An error due to an excessive current of the Y motor was detected.	



Message	Cause	Solution
ERROR 44d UV UNIT FAN ERROR	The UV unit fan does not operate (displayed at 135 degrees C and higher).	<ul style="list-style-type: none"> <li>Turn off the main power to the machine and turn it on after a while.</li> <li>If the same error message appears again, contact your local distributor to call for service.</li> </ul>
ERROR 504 CLAMP UP	The function of executing is ended for raising the clamp lever.	(Supported from the firmware ver.3.00)
ERROR 505 MEDIA JAM L	The media jam occurs.	<ul style="list-style-type: none"> <li>Remove the media and reset it.</li> </ul>
ERROR 50c MEDIA WIDTH SENSOR	The media width has not been detected correctly.	<ul style="list-style-type: none"> <li>Check the media set position. (☞ P.2-8)</li> <li>Clean the media sensor. (☞ P.4-4)</li> </ul>
ERROR 509 HDC POSCNT	A HDC position counter error occurred.	<ul style="list-style-type: none"> <li>Turn off the main power to the machine and turn it on after a while.</li> <li>If the same error message appears again, contact your local distributor to call for service.</li> </ul>
ERROR 50a Y ORIGIN	Y-origin could not be detected.	
ERROR 50f L-SCALE BLACK	Abnormal linear scale.	
ERROR 516 MEDIA SET POSITION R	The media is set outside the proper area.	<ul style="list-style-type: none"> <li>Check the media set position. (☞ P.2-8)</li> </ul>
ERROR 516 MEDIA SET POSITION L		
ERROR 519 NEGATIVE P. SENSOR	The value of the negative pressure sensor is abnormal.	<ul style="list-style-type: none"> <li>Perform "PRESSURE ADJUST (☞ P.5-9)" of the maintenance. Even if you performed this, when the message is displayed, contact your local distributor to call for service.</li> </ul>
ERROR 51a POSITIVE P. SENSOR	The value of the positive pressure sensor is abnormal.	
!PRE HEATER BRK !PRT HEATER BRK !POST HEATER BRK	The temperature in the media heater won't rise.	<ul style="list-style-type: none"> <li>Check whether the heater power switch near the main power switch is ON.</li> <li>Turn off the main power to the machine and turn it on after a while.</li> <li>If the same error message appears again, contact your local distributor to call for service.</li> </ul>
ERROR 617 SUBTANK SNN: 12345678	The liquid level sensor abnormality of the sub tank has been detected.	<ul style="list-style-type: none"> <li>Turn off the main power to the machine and turn it on after a while.</li> <li>If the same error message appears again, contact your local distributor to call for service.</li> </ul>
ERROR 618 TANKlevelH : 12345678	Though a certain amount was consumed, there is no change in the sub tank sensor High.	<ul style="list-style-type: none"> <li>Perform "SUB TANK (☞ P.5-8)" of the maintenance.</li> <li>Even if you performed this, when the message is displayed, contact your local distributor to call for service.</li> </ul>
ERROR 619 TANKlevelL : 12345678	Though a certain amount was consumed, there is no change in the sub tank sensor Low.	
ERROR 61a OVER FLOW : 12345678	Overflow from the sub tank has been detected.	

Message	Cause	Solution	
ERROR 61b SUPPLY INK : 12345678	Ink could not be supplied to the sub tank.	<ul style="list-style-type: none"> <li>Perform "SUB TANK (☞ P.5-8) " of the maintenance. Also check the remaining amount of ink in the cartridge. Even if you performed this, when the message is displayed, contact your local distributor to call for service.</li> </ul>	
ERROR 61c NEGATIVE P. CONTROL	Starting of the negative pressure control has an abnormality.	<ul style="list-style-type: none"> <li>Perform "PRESSURE ADJUST (☞ P.5-9)" of the maintenance. Even if you performed this, when the message is displayed, contact your local distributor to call for service.</li> </ul>	
ERROR 61d NEGATIVE P. Not Enough	The negative pressure cannot be kept properly		
ERROR 61e NEGATIVE P. OVER			
ERROR 61f POSITIVE P. CONTROL	Starting of the positive pressure control has an abnormality.		
ERROR 620 POSITIVE P. Not Enough	The positive pressure cannot be kept properly.	<ul style="list-style-type: none"> <li>Perform "PRESSURE ADJUST (☞ P.5-9)" of the maintenance. Even if you performed this, when the message is displayed, contact your local distributor to call for service.</li> </ul>	
ERROR 621 POSITIVE P. OVER			
ERROR 627 INSERT CARTRIDGE	There is a slot in which the cartridge has not been inserted more than a certain time.	<ul style="list-style-type: none"> <li>Set a cartridge.</li> </ul>	
ERROR 702 THERMISTOR	The thermistor of a heater is defective.	<ul style="list-style-type: none"> <li>Turn off the main power to the machine and turn it on after a while. If the same error message appears again, contact your local distributor to call for service.</li> </ul>	
ERROR 707 !H1 HEATER BREAK	A head heater is disconnected.		
ERROR 70c UV UNIT BRK	The UV unit is disconnected.		
ERROR 70d UV UNIT TEMP ERROR	The UV lamp temperature is abnormal.		
ERROR 712 UV UNIT TEMP. HIGH	The UV lamp temperature is abnormal. (High)		
ERROR 713 UV UNIT TEMP. LOW	The UV lamp temperature is abnormal. (Low)		
ERROR 70e UV THERMISTOR BRK	The UV unit thermistor is disconnected.		
ERROR 710 HEATER TEMP ERROR	The temperature abnormality of the heater has been detected. When this error occurred and if the temperature abnormality cannot be resolved, the power supply of the machine is forcibly turned off.		
ERROR 901 INVALID OPERATION	Due to a certain error, the function cannot be performed.		<ul style="list-style-type: none"> <li>Return to the local screen, check the error status and take a countermeasure.</li> </ul>
ERROR 902 DATA REMAIN	There remains received data that has not yet been printed.		<ul style="list-style-type: none"> <li>Execute the data clear function. (☞ P.2-26)</li> </ul>

Message	Cause	Solution
ERROR 90d NO HEAD SELECT	The number of mounted heads is "0".	<ul style="list-style-type: none"> <li>Turn off the main power to the machine and turn it on after a while.</li> <li>If the same error message appears again, contact your local distributor to call for service.</li> </ul>
ERROR 90f PRINT AREA SHORT	The media width or the media length required for printing is not enough.	<ul style="list-style-type: none"> <li>Change the media to the one with enough width or length.</li> <li>When the media width narrows because the origin moved, slide the origin to the right to widen the effective media width.</li> </ul>
ERROR 04 PARAM ROM	The parameter has an error.	<ul style="list-style-type: none"> <li>Turn off the main power to the machine and turn it on after a while.</li> <li>If the same error message appears again, contact your local distributor to call for service.</li> </ul>

## SYSTEM HALT

Message	Solution
SYSTEM HALT 000: MESSAGE	<p>Turn off the main power to the machine and turn it on after a while.</p> <p>If the same error message appears again, check the number and contact your local distributor to call for service. ("000" is the error No.)</p>



# Chapter 6

## Appendix



### **This chapter**

contains the lists of the specifications and functions of this machine.

Specifications .....	6-2
Machine specifications .....	6-2
Ink specifications .....	6-3
Setting orders depending on ink type .....	6-4
Setting orders of ink cartridges .....	6-4
Sheet for inquiry .....	6-5
Warning labels .....	6-6
Function Flowchart .....	6-8

# Specifications

## Machine specifications

Item		JV400-130SUV	JV400-160SUV	SUV-160
Print head	Method	Drop-on-demand piezoelectric print heads		
	Specification	2 head		
Drawing mode (scan x feed)	4-color	900x900 : Bi/Uni 6/12/24pass 900x1200 : Bi/Uni 8/16/32pass 1200x900 : Bi/Uni 6/12/24pass 1200x1200 : Bi/Uni 8/16/32pass		1200x900 : Bi/Uni 12pass 1200x1200 : Bi/Uni 16pass 1200x900 : Bi/Uni 24pass
Usable inks		M,C,Y,K		M,C,Y,K, CL
		SU100: 4 colors (K,M,C,Y)		SU200: 4 colors(K,M,C,Y) + CL (Clear)
Ink supply		Supplying from ink cartridges through tubes. Ink cartridge replacement type : Only at 4 colors: Supplying by Toggle switchover with 2 cartridges/color 600cc ink pack supply, 8 slot		
Capacity of ink cartridge		At 4 colors : 600cc 2 cartridges for each color		At 4 colors : 600cc 2 cartridges for each color At 4 colors +CL (Clear) : 600cc 2 cartridges for [C, M, CL], 600cc 1 cartridges for [Y, K]
Media type		Tarpaulin / Weatherproof PVC		PVC Synthetic Leather
Max. printing width		1361mm	1610mm	
Roll Media size	Maximum	1371mm	1620mm	
	Minimum	210mm		
	Thickness	0.2 mm or less		Before printing, test your transport and check the print gaps. (P.1-18)
	Roll outside diameter	φ 180mm or less		
	Roll weight <sup>*1</sup>	25kg or less		
	Roll inside diameter	3 or 2 inches		
	Printing surface	Side facing outward		
Roll end treatment	The roll end is gently fixed to the core with weak-adhesive tape or weak glue for easy removal.			
Margin	Roll media	Left end and right end : 15 mm (Default)		
Distance accuracy	Absolute accuracy	Whichever the larger one of ± 0.3 mm or ± 0.3 % of the designated		
	Reproducibility	Whichever the larger one of ± 0.2 mm or ± 0.1 % of the designated		
Perpendicularity		± 0.5 mm / 1000 mm		
Media skew		5 mm or less / 10 m variable		
Head height adjustment		L range : 1.8mm M range : 2.3mm H range : 2.8mm		
Cutting of media		Cutting of Y direction by the head cutter, Cutting accuracy (steps) : 1.0 mm or less.		
Media delivery		Take-up device supplied as a standard accessory (switching possible between face in and face out).		
Waste ink tank		Bottle type ( 2,000 cc)		
Interface		USB 2.0		
Command		MRL- III		
Noise	during standby	Less than 58 dB (FAST-A, Front & Rear & Left & Right 1 m)		
	during continuous printing	Less than 65 dB		
	during discontinuous printing	Less than 75 dB		
Safety Standard	AC100 - 120V	VCCI-Class A, FCC Part 15-Class A, UL 60950		-
	AC200 - 240V	CE Marking (EMC/Low Voltage/Machinery), CB Certificate, RoHS		

Item		JV400-130SUV	JV400-160SUV	SUJV-160
Power	AC100 - 120V	INLET1: 100 - 120V, 12A, 50/60Hz INLET2: 100 - 120V, 12A, 50/60Hz		-
	AC220 - 240V	INLET1: 220 - 240V, 8A, 50/60Hz INLET2: 220 - 240V, 8A, 50/60Hz		INLET1: 200 - 240V, 8A, 50/60Hz INLET2: 200 - 240V, 8A, 50/60Hz
Power consumption *2		2120 W x2 or less		
Recommended Environment	Available temp.	20 °C to 30 °C		
	Humidity	35 to 65% Rh (No condensation)		
	Guaranteed temp.	20 °C to 25 °C		
	Temperature change	± 10 °C / h or less		
	Dust	0.15mg/m <sup>3</sup> (Equivalent to normal office level)		
	Highest operation height	2000 m		
Weight		212 kg	250 kg	
Outside dimensions		2634 mm(W) x 861 mm(D) x 1435mm(H)	2879 mm(W) x 861mm(D) x 1435 mm(H)	

\*1. Without deflection of the roll when it is retained at both ends.

\*2. Main unit and heater included.

## Ink specifications

Item		JV400-130SUV / JV400-160SUV	SUJV-160
Supply		Ink pack	
Color		Black ink (K) Cyan ink (C) Magenta ink (M) Yellow ink (Y)	Black ink (K) Cyan ink (C) Magenta ink (M) Yellow ink (Y) Clear ink (CL)
Ink capacity		600cml	
Shelf life		SU100 ink The expiration date is as described in the ink cartridge. However, even within the expiration date after opening, it is within 3 months.	SU200 ink The expiration date is as described in the ink cartridge. However, even within the expiration date after opening, it is within 3 months.
Storage temperature	Storage	0 to 25°C (Average daily temperature) • Be sure to keep a vessel in the airtight condition.	
Ink maintenance		Shake the ink regularly before use. If you do not shake the ink regularly, the print quality may deteriorate. The shaking frequency depends on the ink type and color. Use the ink cartridge recommended by us. Solvent UV ink: Once a Month	



- Do not disassemble ink cartridges and do not refill them with ink.
- Please make sure to read SDS (Safety Data Sheet) before use.

# Setting orders depending on ink type

The setting value and the setting orders of the ink cartridges differ depending on the ink type you use.

## Setting orders of ink cartridges

The orders of ink cartridges set in the ink station differ depending on the ink set you use.



- Set the ink cartridge according to the cartridge label under the ink station.

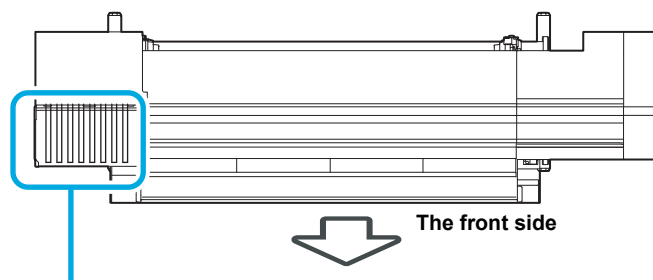

### ● JV400-130SUV / JV400-160SUV

スロット番号		1	2	3	4	5	6	7	8
4 colors model	SU100	M	M	C	C	Y	Y	K	K

### ● SUJV-160

スロット番号		1	2	3	4	5	6	7	8
4 colors model	SU200 ink	M	M	C	C	Y	Y	K	K
(4 colors + CL) model	SU200 ink	M	M	C	C	Y	K	CL	CL



# Sheet for inquiry

Use this sheet for troubles and abnormal functions of the machine.  
Fill in the following necessary items, and then fax the sheet to our sales office.







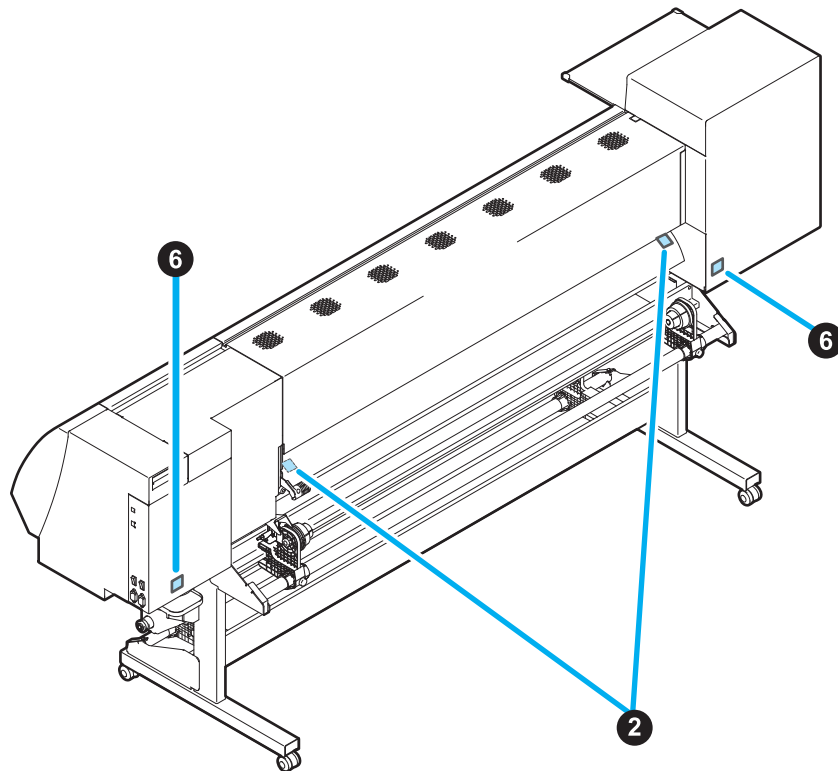
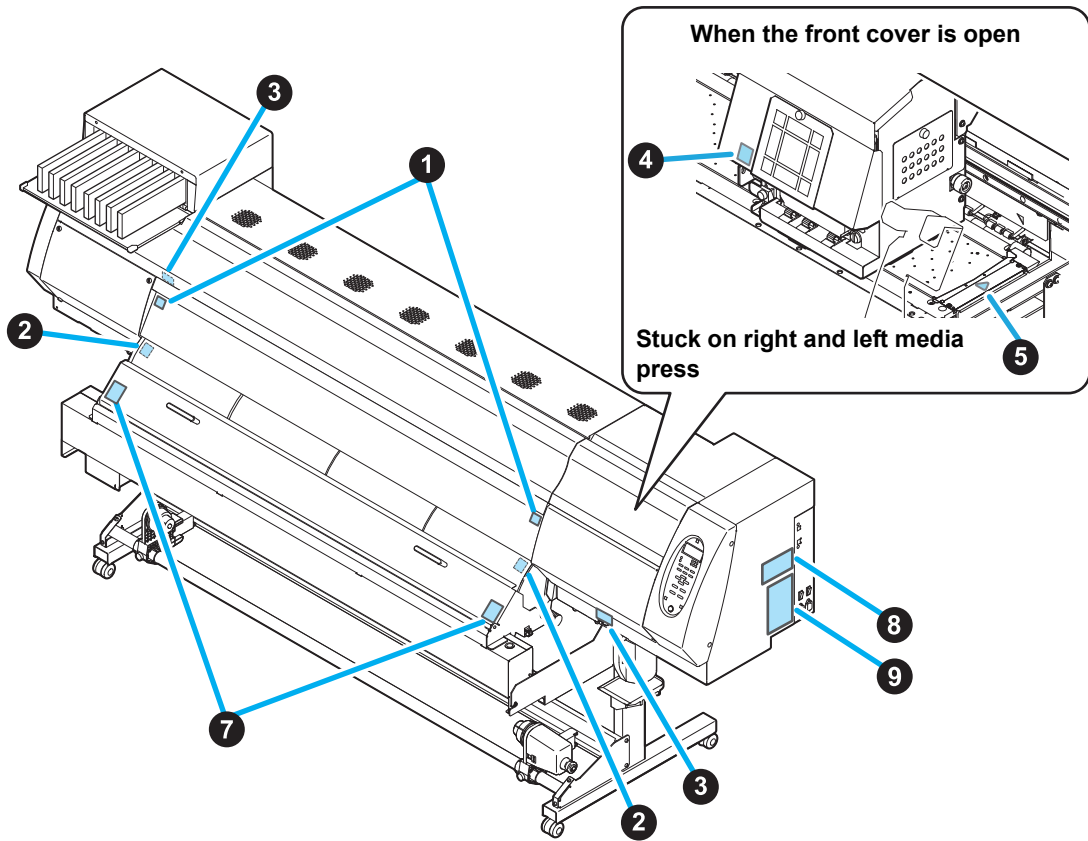

<b>Company name</b>	
<b>Person in charge</b>	
<b>Telephone number</b>	
<b>machine model</b>	
<b>Operating OS</b>	
<b>Machine information *1</b>	
<b>Error message</b>	
<b>Contents of inquiry</b>	

\*1. Refer to "Confirming Machine information" of "Convenient using" then fill in necessary information. (☞ P.3-38)

# Warning labels

Warning labels are stuck on the machine. Be sure to fully understand the warning given on the labels. If a warning label is illegible due to stains or has come off, purchase a new one from a distributor or our sales office.



No.	Reorder	Label	No.	Reorder	Label								
1	M907833		2	M903239									
3	M903330		4	M903405									
5	M906144		6	M907935									
7	M905980	<p><b>▲ WARNING</b></p> <p> Ultraviolet is radiated. If you touch UV, you may lose your sight and get burnt.</p> <p><b>ULTRAVIOLET RADIATION</b></p> <p><b>▲ PRÉVENIR</b></p> <p> Les ultraviolets sont irradiés. Par les ultraviolets, vous pouvez perdre votre et pouvez me brûler.</p> <p><b>RAYONS ULTRAVIOLETS</b></p> <p><b>▲ WARNING</b></p> <p> 紫外線が照射されています。紫外線を浴びると、失明や火傷の恐れがあります。</p> <p><b>ULTRAVIOLET RADIATION</b></p>	8	M905624	<table border="1"> <tr> <td><b>▲ 注意</b></td> <td><b>▲ WARNING</b></td> </tr> <tr> <td>過剰な電流が 発生し、感電する恐れ があります。</td> <td>HIGH LEAKAGE CURRENT EARTH CONNECTION ESSENTIAL BEFORE CONNECTING SUPPLY</td> </tr> <tr> <td><b>▲ AVERTISSEMENT</b></td> <td><b>▲ WARNING</b></td> </tr> <tr> <td>COURANT DE FUITE ÉLEVÉ CONNECTER LA MISE À LA TERRE AVANT DE CONNECTER L'ALIMENTATION</td> <td>HÖHER KREICHSTROM BITTE ERDANSCHLÜSSEN BEVOR SIE STROMZUFÜHR ANSCHLIESSEN</td> </tr> </table>	<b>▲ 注意</b>	<b>▲ WARNING</b>	過剰な電流が 発生し、感電する恐れ があります。	HIGH LEAKAGE CURRENT EARTH CONNECTION ESSENTIAL BEFORE CONNECTING SUPPLY	<b>▲ AVERTISSEMENT</b>	<b>▲ WARNING</b>	COURANT DE FUITE ÉLEVÉ CONNECTER LA MISE À LA TERRE AVANT DE CONNECTER L'ALIMENTATION	HÖHER KREICHSTROM BITTE ERDANSCHLÜSSEN BEVOR SIE STROMZUFÜHR ANSCHLIESSEN
<b>▲ 注意</b>	<b>▲ WARNING</b>												
過剰な電流が 発生し、感電する恐れ があります。	HIGH LEAKAGE CURRENT EARTH CONNECTION ESSENTIAL BEFORE CONNECTING SUPPLY												
<b>▲ AVERTISSEMENT</b>	<b>▲ WARNING</b>												
COURANT DE FUITE ÉLEVÉ CONNECTER LA MISE À LA TERRE AVANT DE CONNECTER L'ALIMENTATION	HÖHER KREICHSTROM BITTE ERDANSCHLÜSSEN BEVOR SIE STROMZUFÜHR ANSCHLIESSEN												
9	For 100V M909057 M909058	<p>M909058 (JV400-130SUV)</p> <p>M909057 (JV400-160SUV)</p>											
		<p>Equipment to be connected to earthed mains outlet only. Appareil à brancher sur une prise à terre.</p> <p>この装置は、クラスA情報技術装置です。この装置を家庭環境で使用すると電磁妨害を引き起こすことがあります。この場合には使用者が適切な対策を講ずるよう要求される場合があります。</p> <p>This device complies with Part 15 of the FCC Rules. Operation is subject to the following two conditions: ① This device may not cause harmful interference, and ② This device must accept any interference received, including interference that may cause undesired operation.</p> <p>This Class A digital apparatus complies with Canadian ICES-003.</p> <p>Cet appareil numérique de la classe A est conforme à la norme NMB-003 du Canada.</p> <p>MODEL-SERIAL NO. Modeli-Seriennomer 型番名称-型番コード MODEL-N° DB SRIIB</p> <p><b>JV400-130SUV</b> *****</p> <p>INPUT 100-120V ~ 12A, 50/60Hz INPUT 100-120V ~ 12A, 50/60Hz</p> <p>weight of machine 240kg short circuit rating &amp; Iba electrical diagram no. E20916 MIMAKI ENGINEERING CO., LTD 御牧 高科学技術株式会社 2102-3 Shigeno-otna, Tami, Nagano 389-0512 Japan Year of manufacture Hersteller/Jahr: ***** MADE IN JAPAN Année de fabrication FABRIQUÉ AU JAPON</p> <p><b>CE</b></p>											
		<p>Equipment to be connected to earthed mains outlet only. Appareil à brancher sur une prise à terre.</p> <p>この装置は、クラスA情報技術装置です。この装置を家庭環境で使用すると電磁妨害を引き起こすことがあります。この場合には使用者が適切な対策を講ずるよう要求される場合があります。</p> <p>This device complies with Part 15 of the FCC Rules. Operation is subject to the following two conditions: ① This device may not cause harmful interference, and ② This device must accept any interference received, including interference that may cause undesired operation.</p> <p>This Class A digital apparatus complies with Canadian ICES-003.</p> <p>Cet appareil numérique de la classe A est conforme à la norme NMB-003 du Canada.</p> <p>MODEL-SERIAL NO. Modeli-Seriennomer 型番名称-型番コード MODEL-N° DB SRIIB</p> <p><b>JV400-160SUV</b> *****</p> <p>INPUT 100-120V ~ 12A, 50/60Hz INPUT 100-120V ~ 12A, 50/60Hz</p> <p>weight of machine 240kg short circuit rating &amp; Iba electrical diagram no. E20916 MIMAKI ENGINEERING CO., LTD 御牧 高科学技術株式会社 2102-3 Shigeno-otna, Tami, Nagano 389-0512 Japan Year of manufacture Hersteller/Jahr: ***** MADE IN JAPAN Année de fabrication FABRIQUÉ AU JAPON</p> <p><b>CE</b></p>											
For 200V M909089 M909090 M916901	M909090 (JV400-130SUV)	M909089 (JV400-160SUV)	M916901 (SUJV-160)										
	<p>Equipment to be connected to earthed mains outlet only. Appareil à brancher sur une prise à terre.</p> <p>この装置は、クラスA情報技術装置です。この装置を家庭環境で使用すると電磁妨害を引き起こすことがあります。この場合には使用者が適切な対策を講ずるよう要求される場合があります。</p> <p>This device complies with Part 15 of the FCC Rules. Operation is subject to the following two conditions: ① This device may not cause harmful interference, and ② This device must accept any interference received, including interference that may cause undesired operation.</p> <p>This Class A digital apparatus complies with Canadian ICES-003.</p> <p>Cet appareil numérique de la classe A est conforme à la norme NMB-003 du Canada.</p> <p>MODEL-SERIAL NO. Modeli-Seriennomer 型番名称-型番コード MODEL-N° DB SRIIB</p> <p><b>JV400-130SUV</b> *****</p> <p>INPUT 220-240V ~ 8A, 50/60Hz INPUT 220-240V ~ 8A, 50/60Hz</p> <p>weight of machine 250kg short circuit rating &amp; Iba electrical diagram no. E20916 MIMAKI ENGINEERING CO., LTD 御牧 高科学技術株式会社 2102-3 Shigeno-otna, Tami, Nagano 389-0512 Japan Year of manufacture Hersteller/Jahr: ***** MADE IN JAPAN Année de fabrication FABRIQUÉ AU JAPON</p> <p><b>CE</b></p>	<p>Equipment to be connected to earthed mains outlet only. Appareil à brancher sur une prise à terre.</p> <p>この装置は、クラスA情報技術装置です。この装置を家庭環境で使用すると電磁妨害を引き起こすことがあります。この場合には使用者が適切な対策を講ずるよう要求される場合があります。</p> <p>This device complies with Part 15 of the FCC Rules. Operation is subject to the following two conditions: ① This device may not cause harmful interference, and ② This device must accept any interference received, including interference that may cause undesired operation.</p> <p>This Class A digital apparatus complies with Canadian ICES-003.</p> <p>Cet appareil numérique de la classe A est conforme à la norme NMB-003 du Canada.</p> <p>MODEL-SERIAL NO. Modeli-Seriennomer 型番名称-型番コード MODEL-N° DB SRIIB</p> <p><b>JV400-160SUV</b> *****</p> <p>INPUT 220-240V ~ 8A, 50/60Hz INPUT 220-240V ~ 8A, 50/60Hz</p> <p>weight of machine 250kg short circuit rating &amp; Iba electrical diagram no. E20916 MIMAKI ENGINEERING CO., LTD 御牧 高科学技術株式会社 2102-3 Shigeno-otna, Tami, Nagano 389-0512 Japan Year of manufacture Hersteller/Jahr: ***** MADE IN JAPAN Année de fabrication FABRIQUÉ AU JAPON</p> <p><b>CE</b></p>	<p>Equipment to be connected to earthed mains outlet only. Appareil à brancher sur une prise à terre.</p> <p>この装置は、クラスA情報技術装置です。この装置を家庭環境で使用すると電磁妨害を引き起こすことがあります。この場合には使用者が適切な対策を講ずるよう要求される場合があります。</p> <p>This device complies with Part 15 of the FCC Rules. Operation is subject to the following two conditions: ① This device may not cause harmful interference, and ② This device must accept any interference received, including interference that may cause undesired operation.</p> <p>This Class A digital apparatus complies with Canadian ICES-003.</p> <p>Cet appareil numérique de la classe A est conforme à la norme NMB-003 du Canada.</p> <p>MODEL-SERIAL NO. Modeli-Seriennomer 型番名称-型番コード MODEL-N° DB SRIIB</p> <p><b>SUJV-160</b> *****</p> <p>INPUT 220-240V ~ 8A, 50/60Hz INPUT 220-240V ~ 8A, 50/60Hz</p> <p>weight of machine 250kg short circuit rating &amp; Iba electrical diagram no. E20916 MIMAKI ENGINEERING CO., LTD 御牧 高科学技術株式会社 2102-3 Shigeno-otna, Tami, Nagano 389-0512 Japan Year of manufacture Hersteller/Jahr: ***** MADE IN JAPAN Année de fabrication FABRIQUÉ AU JAPON</p> <p><b>CE</b></p>										
	<p>Equipment to be connected to earthed mains outlet only. Appareil à brancher sur une prise à terre.</p> <p>この装置は、クラスA情報技術装置です。この装置を家庭環境で使用すると電磁妨害を引き起こすことがあります。この場合には使用者が適切な対策を講ずるよう要求される場合があります。</p> <p>This device complies with Part 15 of the FCC Rules. Operation is subject to the following two conditions: ① This device may not cause harmful interference, and ② This device must accept any interference received, including interference that may cause undesired operation.</p> <p>This Class A digital apparatus complies with Canadian ICES-003.</p> <p>Cet appareil numérique de la classe A est conforme à la norme NMB-003 du Canada.</p> <p>MODEL-SERIAL NO. Modeli-Seriennomer 型番名称-型番コード MODEL-N° DB SRIIB</p> <p><b>JV400-130SUV</b> *****</p> <p>INPUT 220-240V ~ 8A, 50/60Hz INPUT 220-240V ~ 8A, 50/60Hz</p> <p>weight of machine 250kg short circuit rating &amp; Iba electrical diagram no. E20916 MIMAKI ENGINEERING CO., LTD 御牧 高科学技術株式会社 2102-3 Shigeno-otna, Tami, Nagano 389-0512 Japan Year of manufacture Hersteller/Jahr: ***** MADE IN JAPAN Année de fabrication FABRIQUÉ AU JAPON</p> <p><b>CE</b></p>	<p>Equipment to be connected to earthed mains outlet only. Appareil à brancher sur une prise à terre.</p> <p>この装置は、クラスA情報技術装置です。この装置を家庭環境で使用すると電磁妨害を引き起こすことがあります。この場合には使用者が適切な対策を講ずるよう要求される場合があります。</p> <p>This device complies with Part 15 of the FCC Rules. Operation is subject to the following two conditions: ① This device may not cause harmful interference, and ② This device must accept any interference received, including interference that may cause undesired operation.</p> <p>This Class A digital apparatus complies with Canadian ICES-003.</p> <p>Cet appareil numérique de la classe A est conforme à la norme NMB-003 du Canada.</p> <p>MODEL-SERIAL NO. Modeli-Seriennomer 型番名称-型番コード MODEL-N° DB SRIIB</p> <p><b>JV400-160SUV</b> *****</p> <p>INPUT 220-240V ~ 8A, 50/60Hz INPUT 220-240V ~ 8A, 50/60Hz</p> <p>weight of machine 250kg short circuit rating &amp; Iba electrical diagram no. E20916 MIMAKI ENGINEERING CO., LTD 御牧 高科学技術株式会社 2102-3 Shigeno-otna, Tami, Nagano 389-0512 Japan Year of manufacture Hersteller/Jahr: ***** MADE IN JAPAN Année de fabrication FABRIQUÉ AU JAPON</p> <p><b>CE</b></p>	<p>Equipment to be connected to earthed mains outlet only. Appareil à brancher sur une prise à terre.</p> <p>この装置は、クラスA情報技術装置です。この装置を家庭環境で使用すると電磁妨害を引き起こすことがあります。この場合には使用者が適切な対策を講ずるよう要求される場合があります。</p> <p>This device complies with Part 15 of the FCC Rules. Operation is subject to the following two conditions: ① This device may not cause harmful interference, and ② This device must accept any interference received, including interference that may cause undesired operation.</p> <p>This Class A digital apparatus complies with Canadian ICES-003.</p> <p>Cet appareil numérique de la classe A est conforme à la norme NMB-003 du Canada.</p> <p>MODEL-SERIAL NO. Modeli-Seriennomer 型番名称-型番コード MODEL-N° DB SRIIB</p> <p><b>SUJV-160</b> *****</p> <p>INPUT 220-240V ~ 8A, 50/60Hz INPUT 220-240V ~ 8A, 50/60Hz</p> <p>weight of machine 250kg short circuit rating &amp; Iba electrical diagram no. E20916 MIMAKI ENGINEERING CO., LTD 御牧 高科学技術株式会社 2102-3 Shigeno-otna, Tami, Nagano 389-0512 Japan Year of manufacture Hersteller/Jahr: ***** MADE IN JAPAN Année de fabrication FABRIQUÉ AU JAPON</p> <p><b>CE</b></p>										

# Function Flowchart

In the case of JV400-130 SUV and SUJV-160, model name, ink, etc. are different from the following.

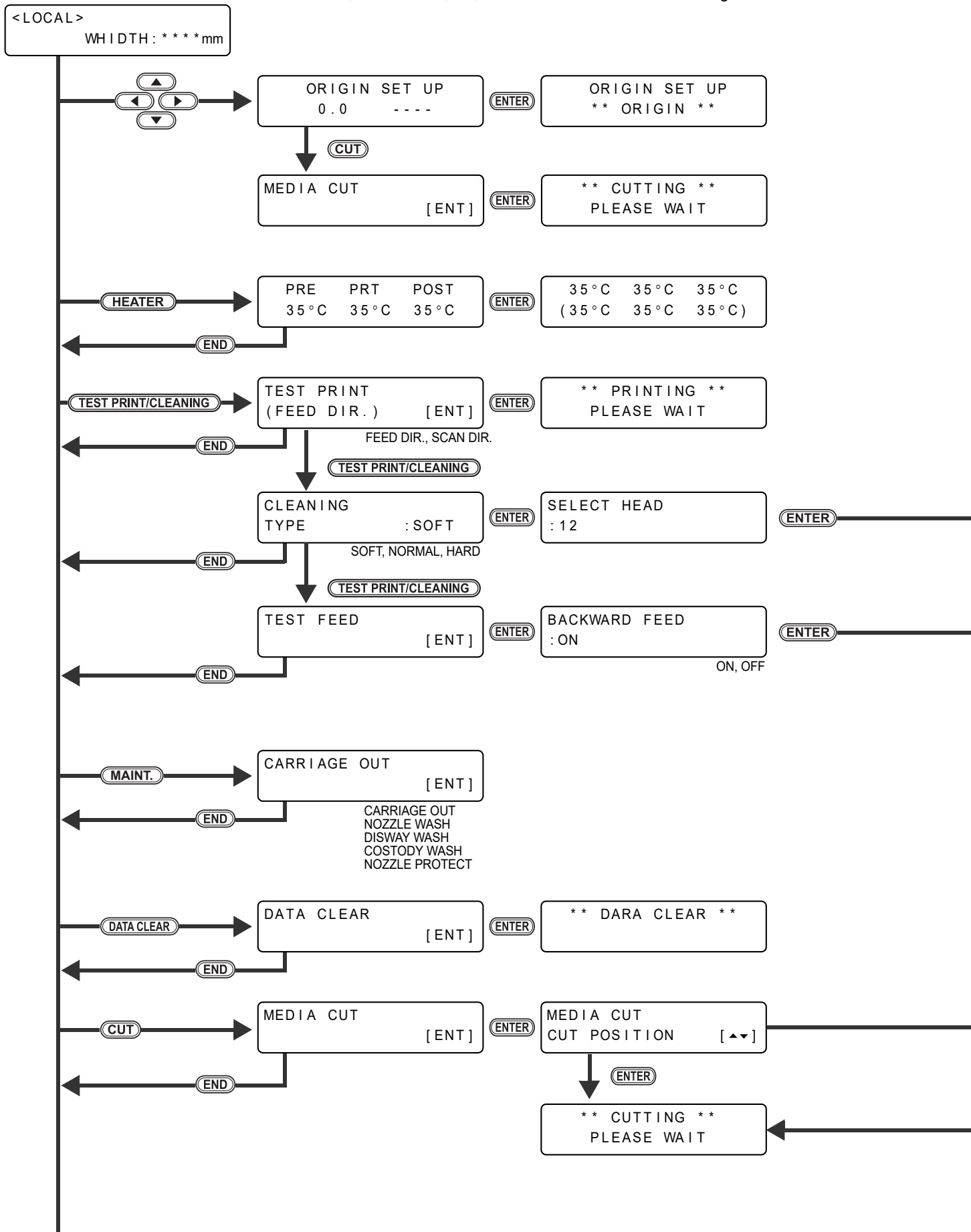

To P.6-10

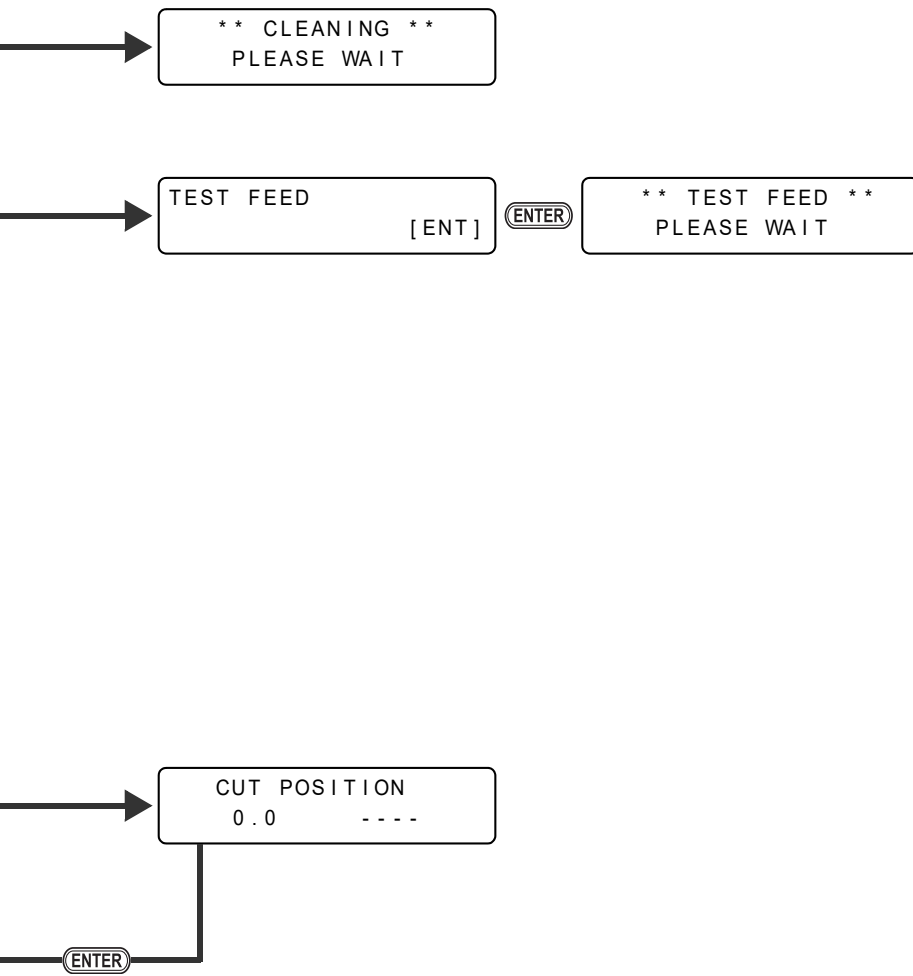

From P.6-8

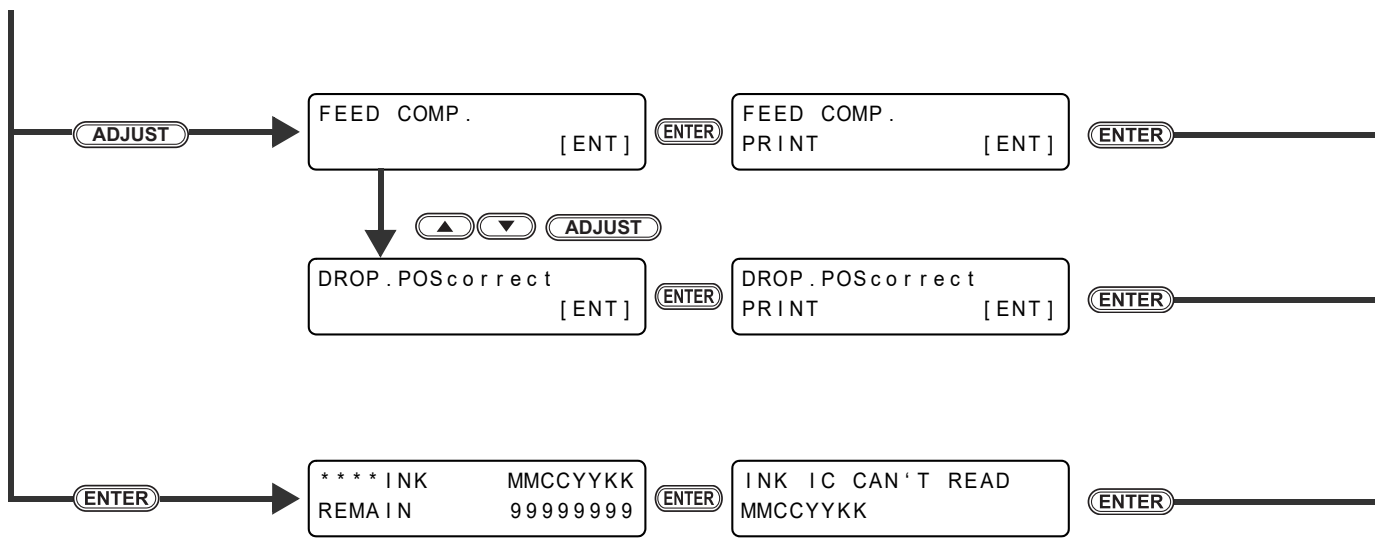

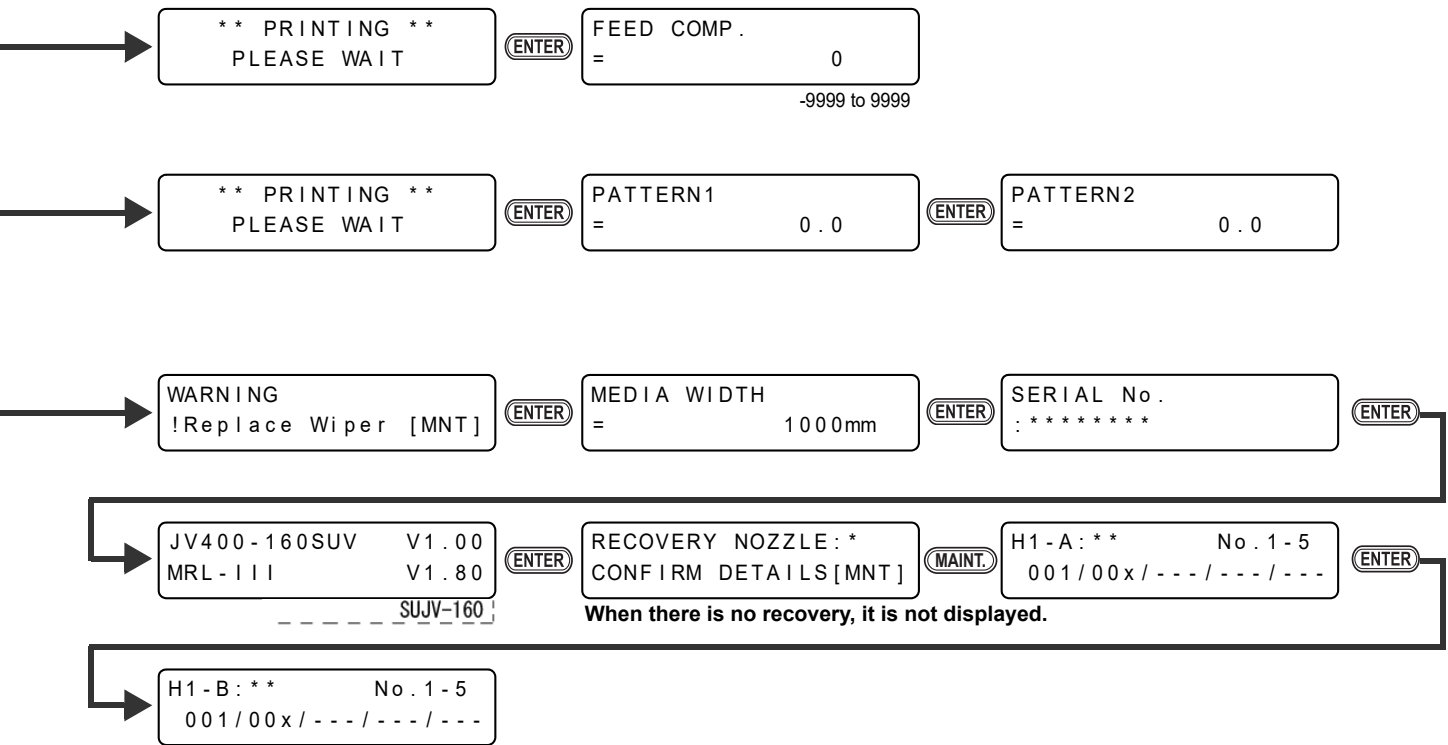

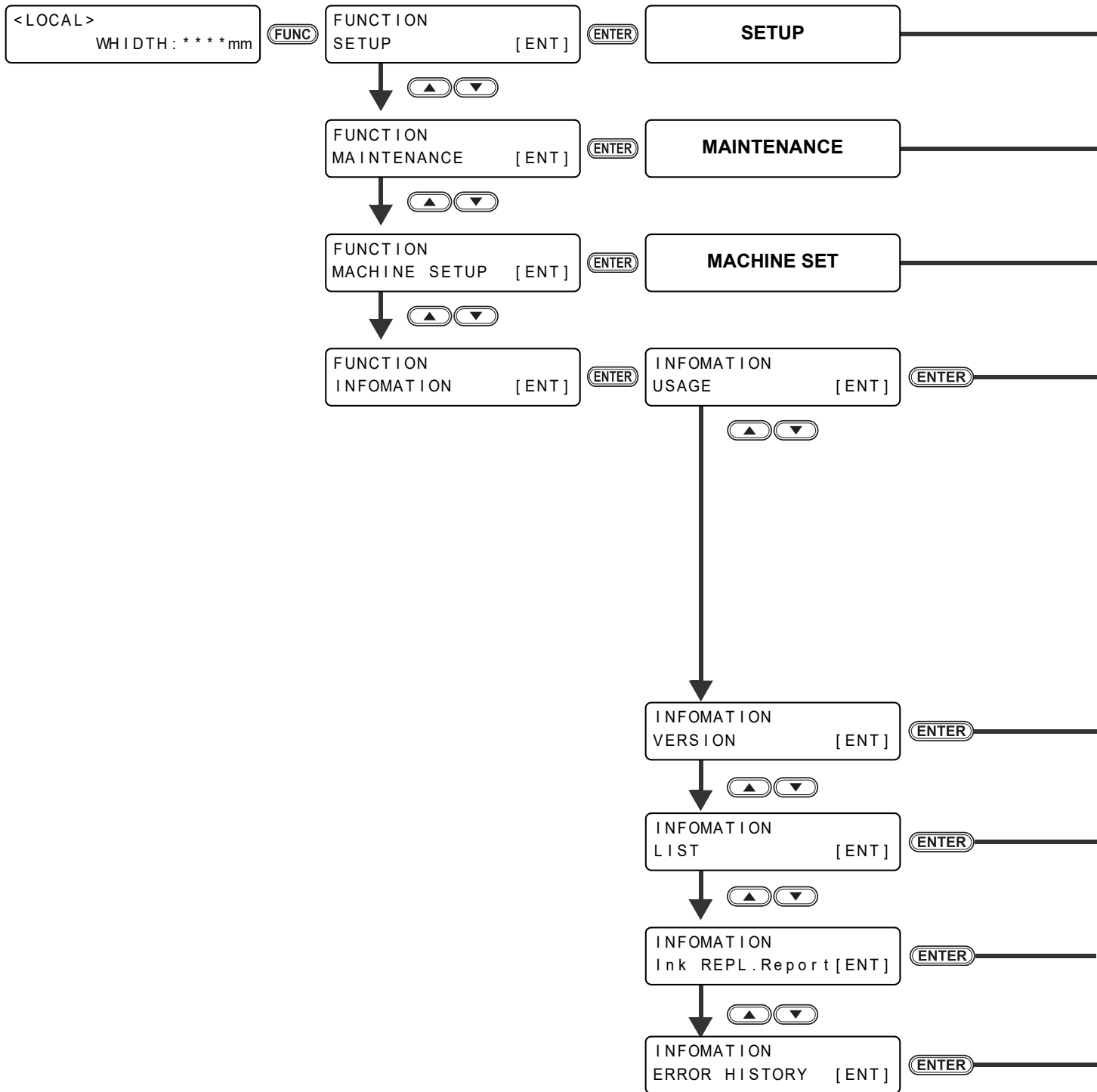



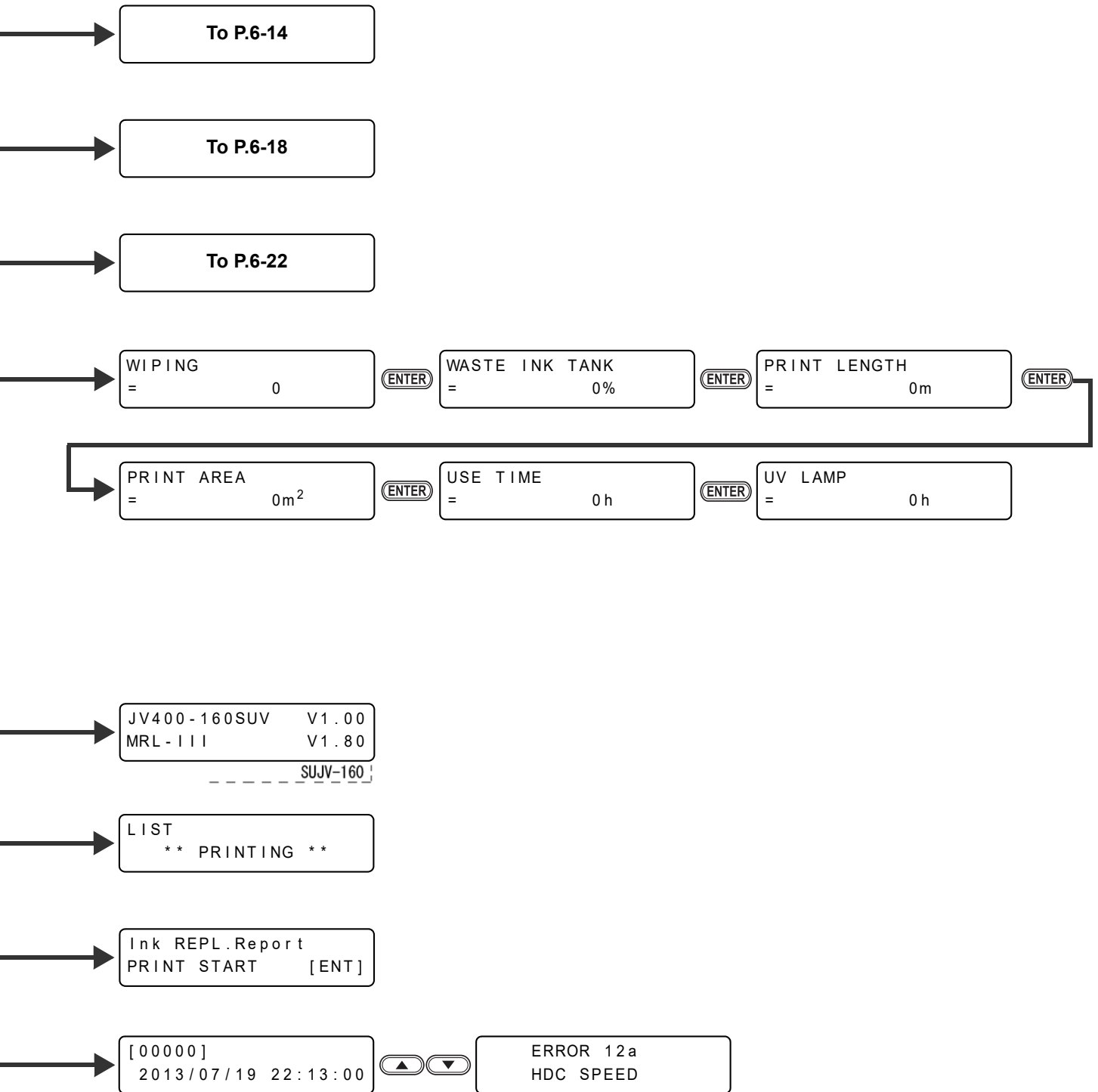

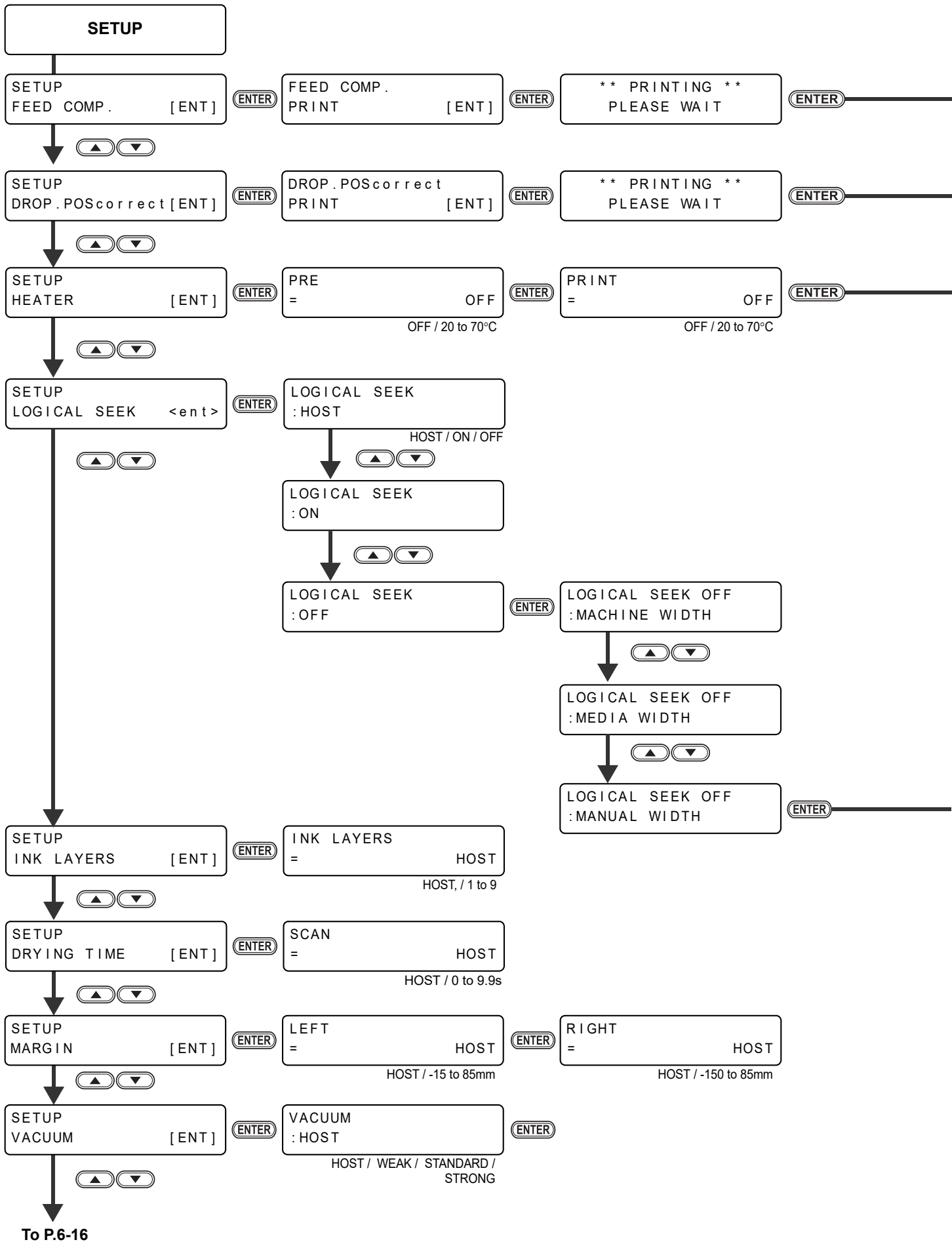

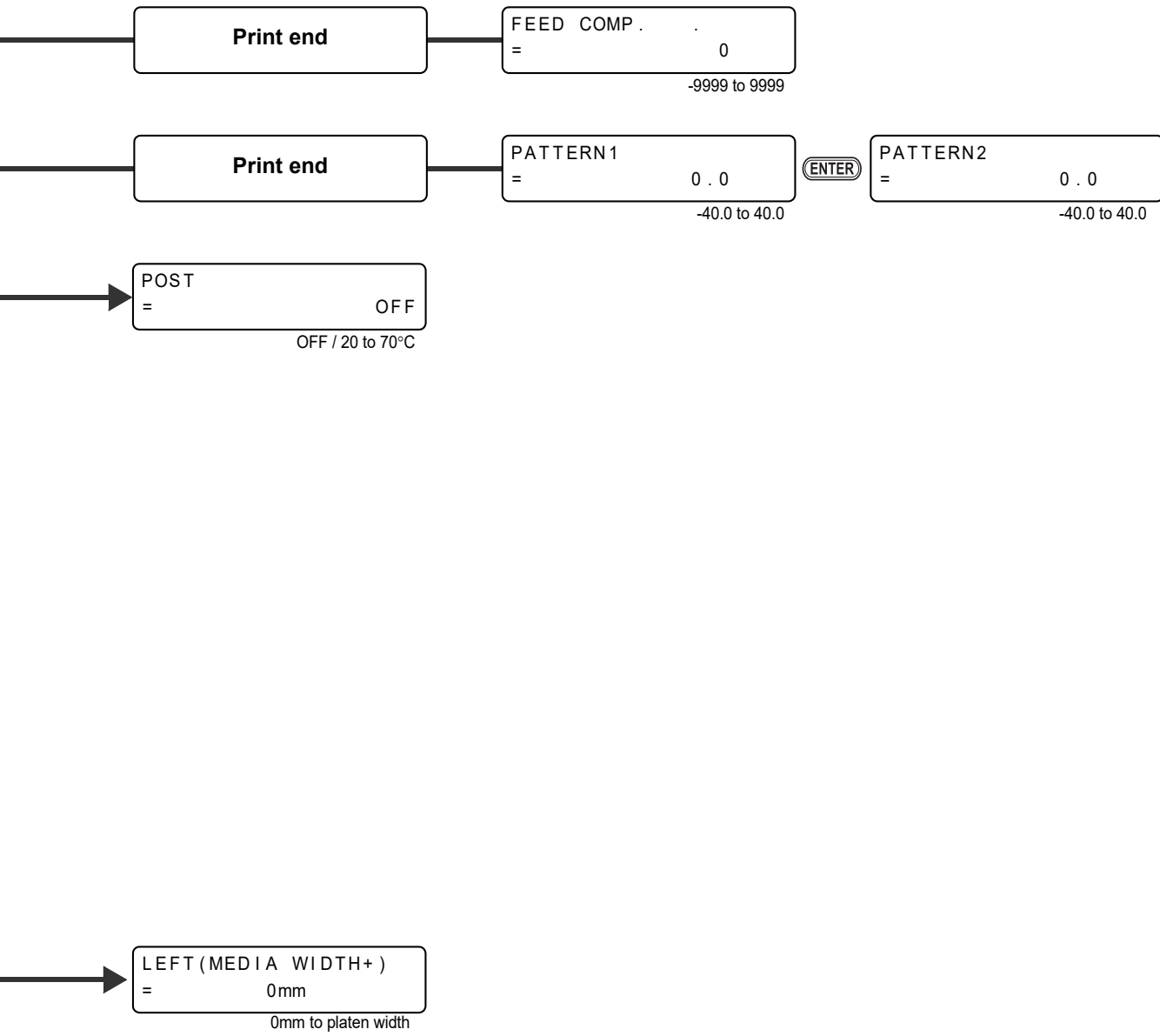

From P.6-14

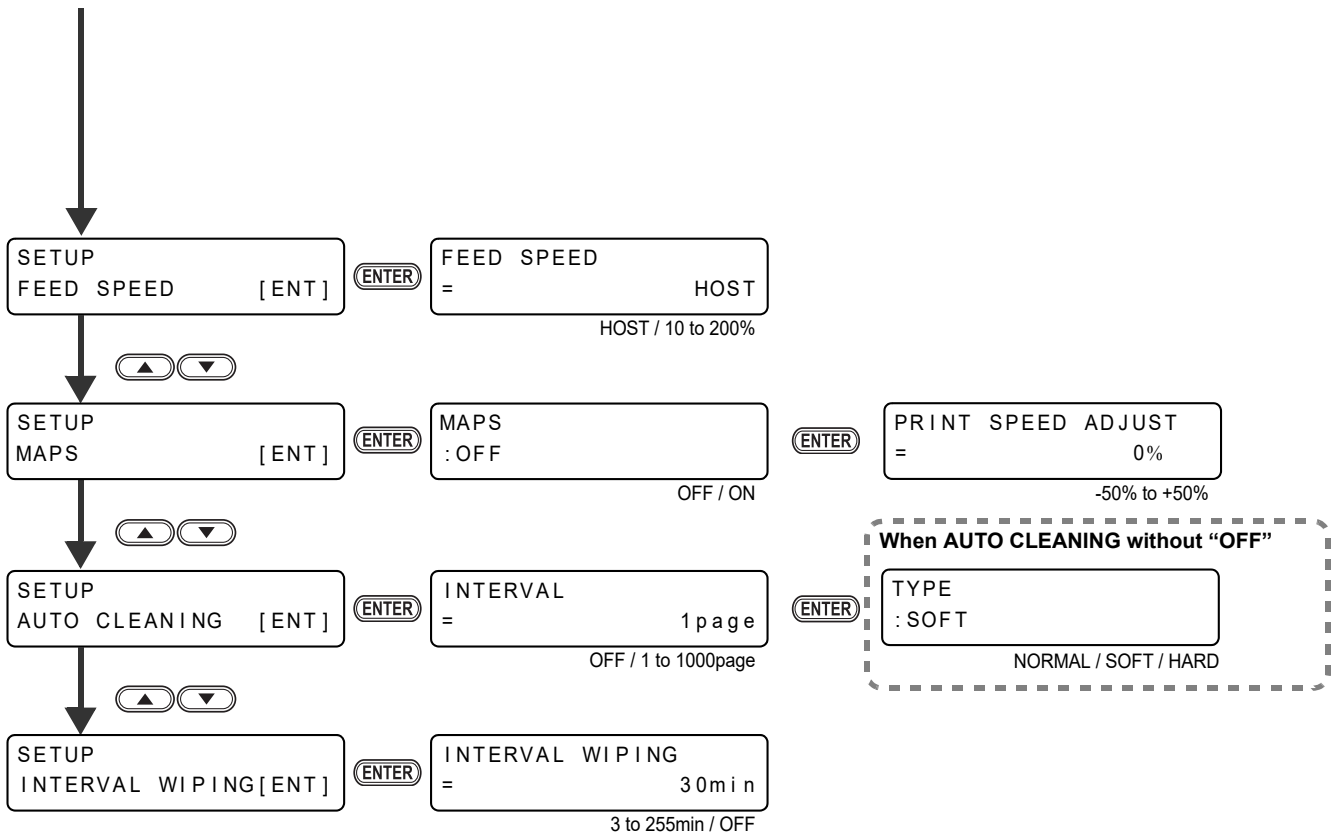



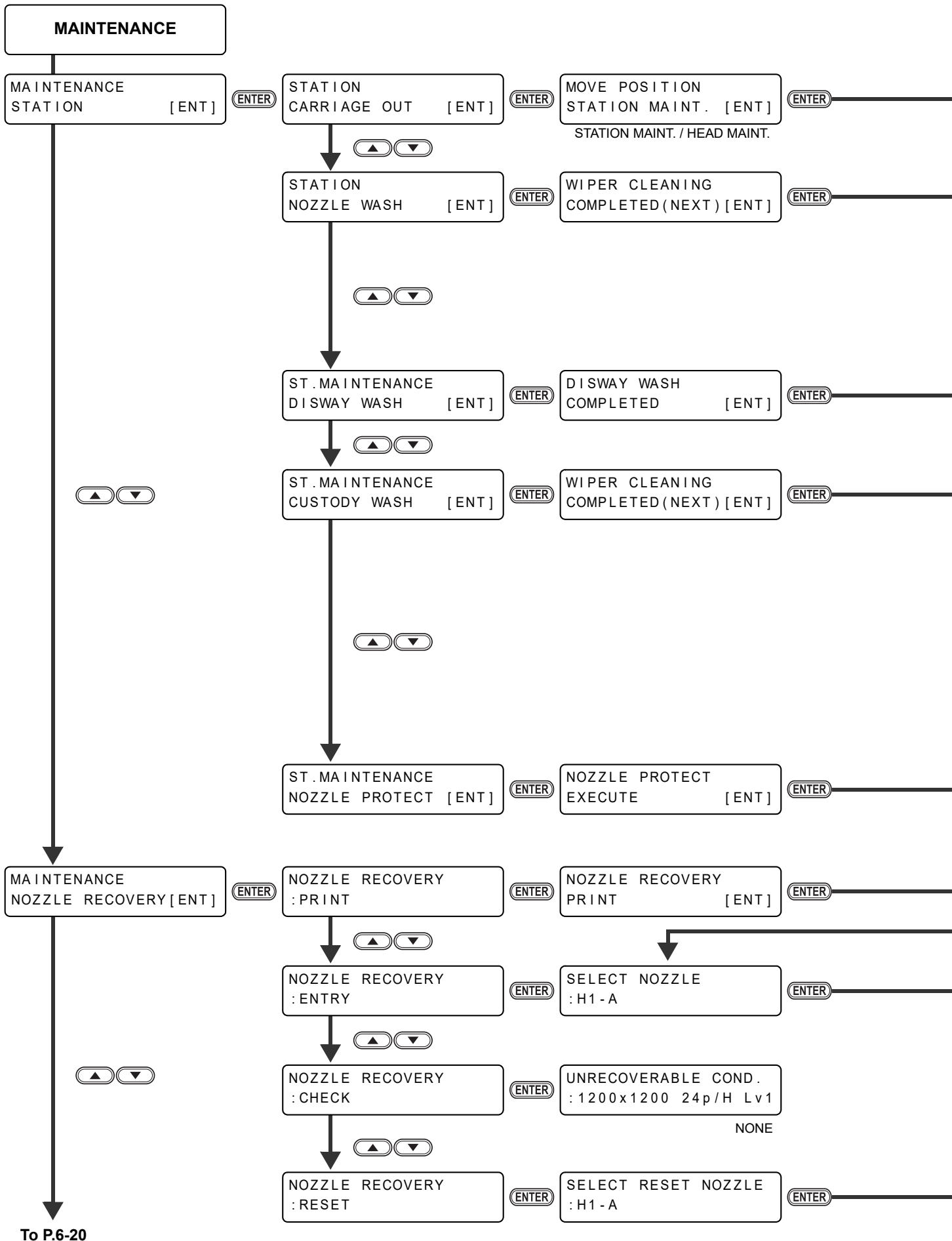

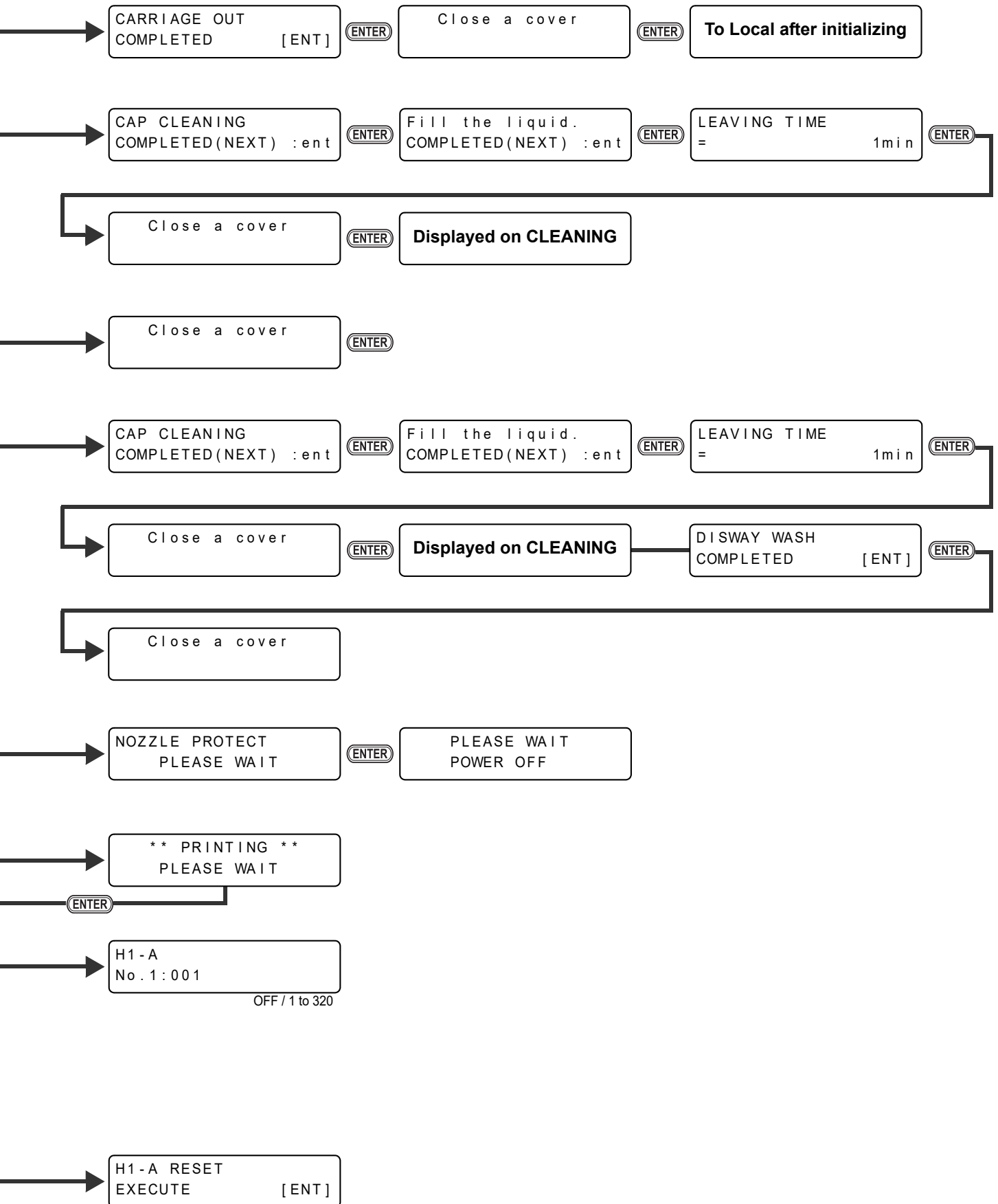

From P.6-18

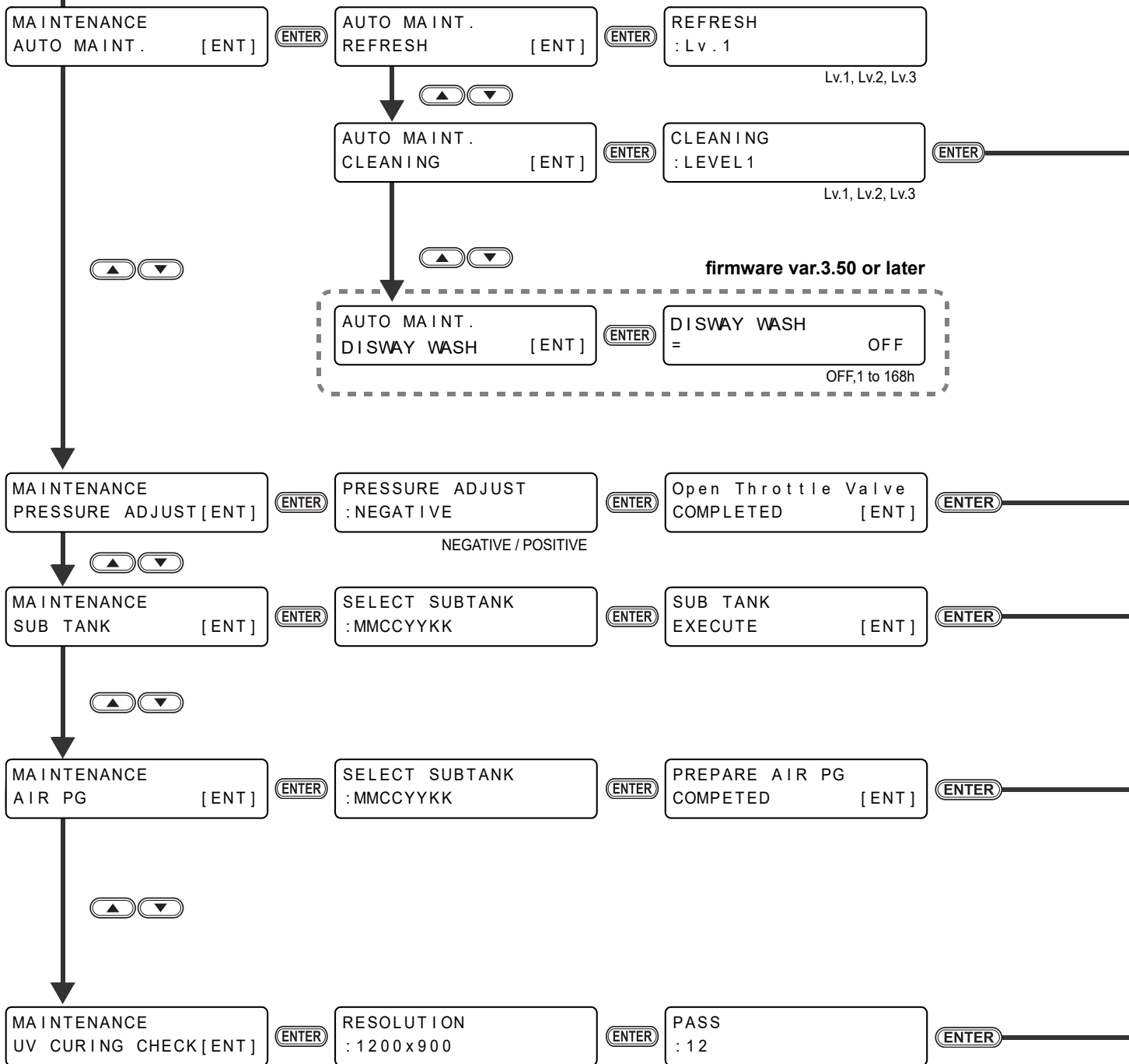



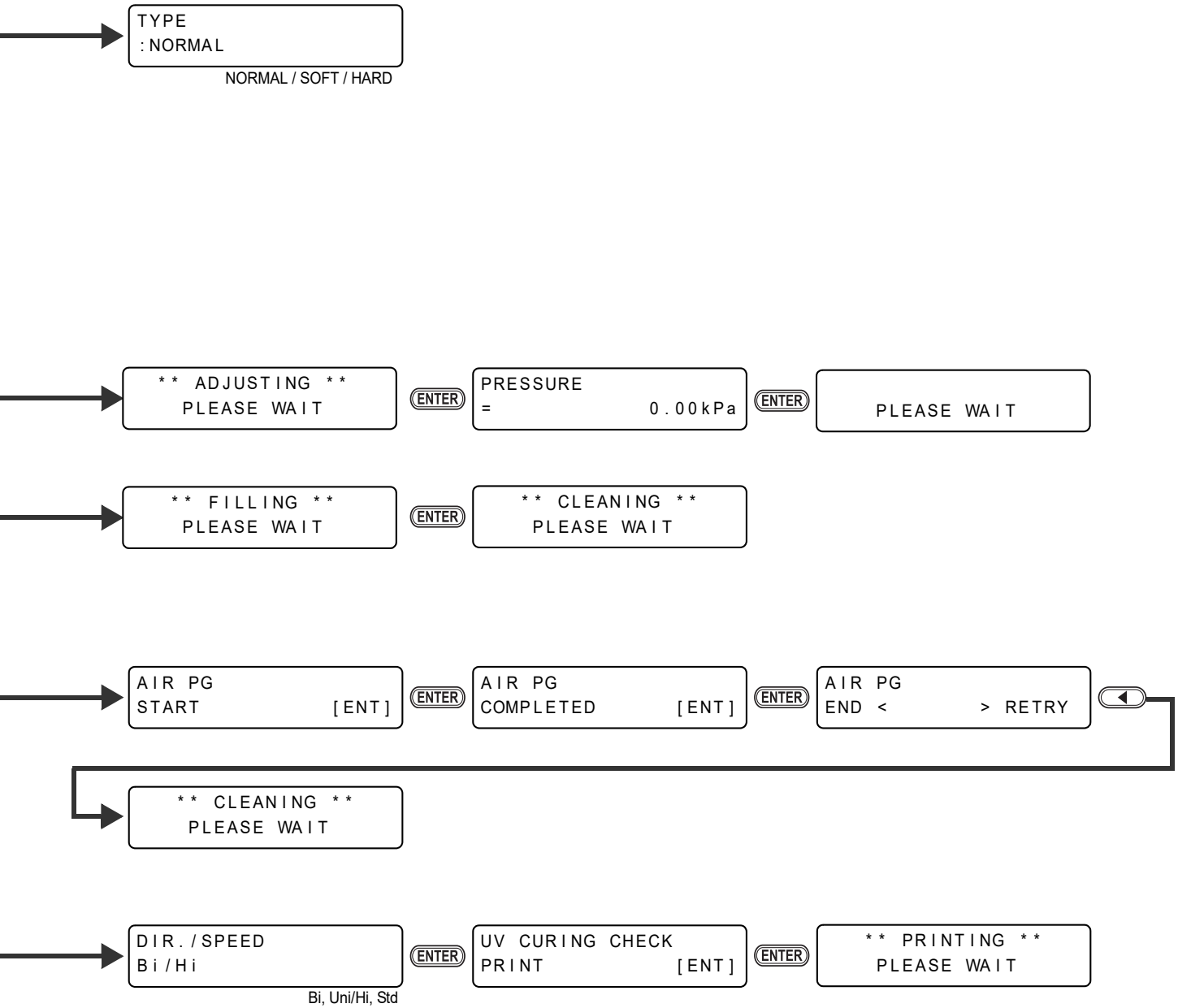

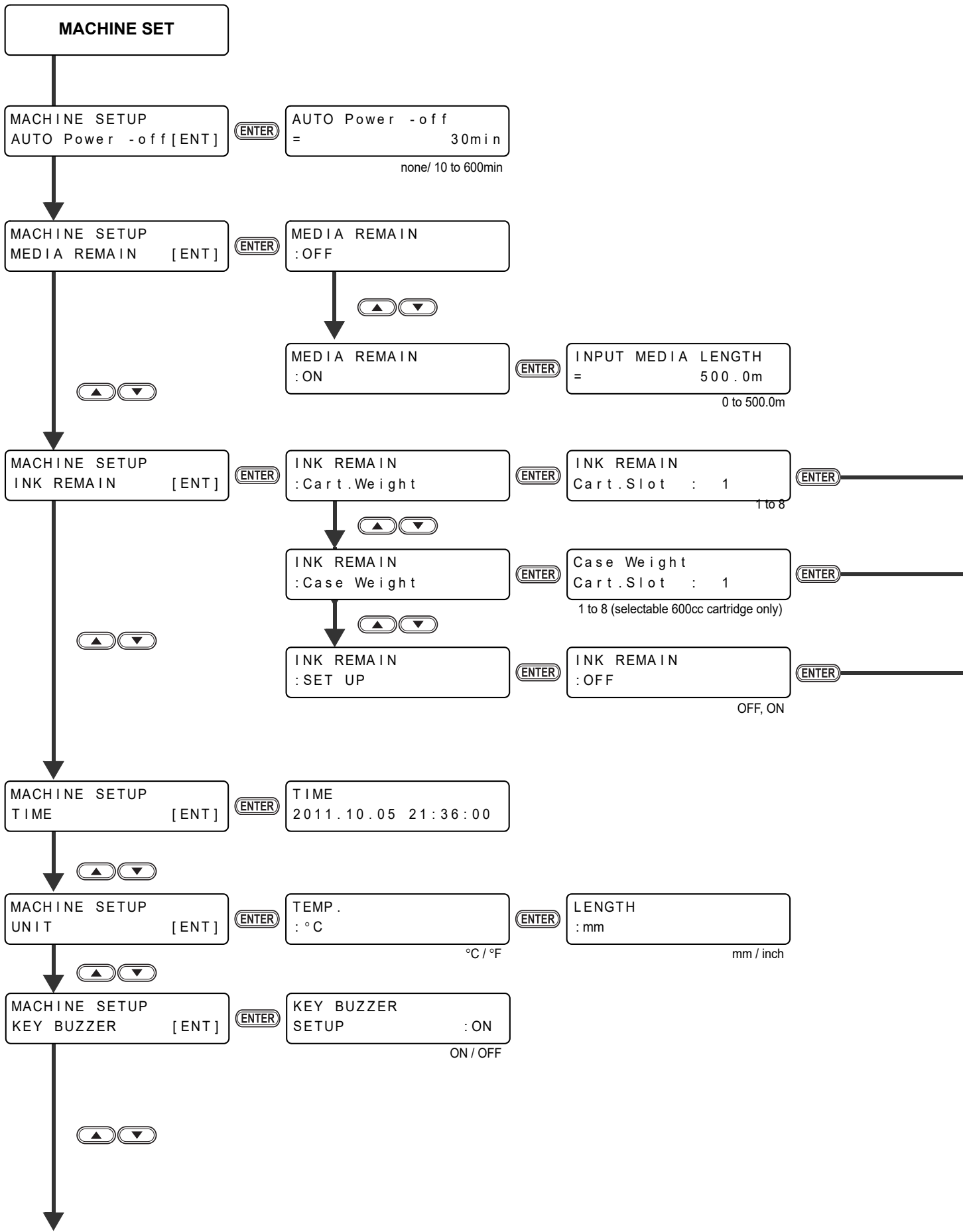

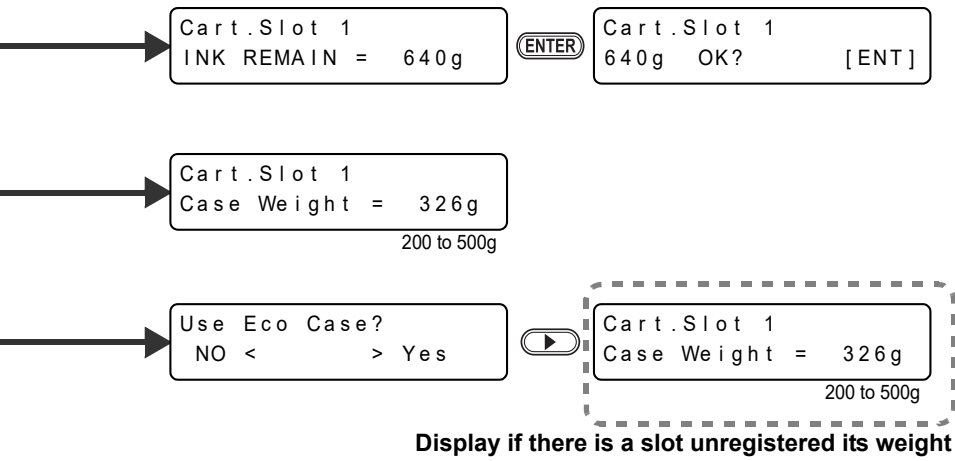

From P.6-22

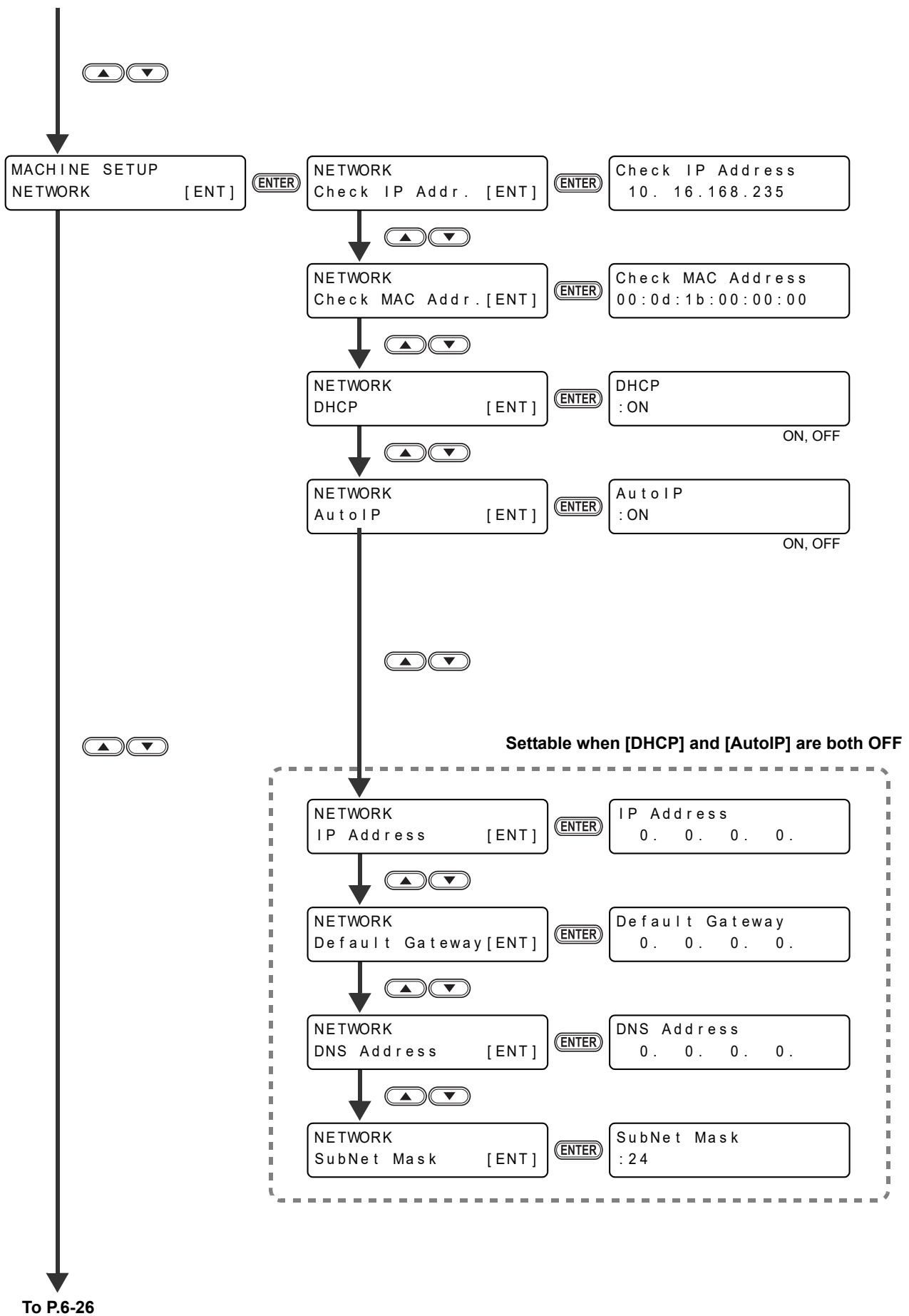



From P.6-24

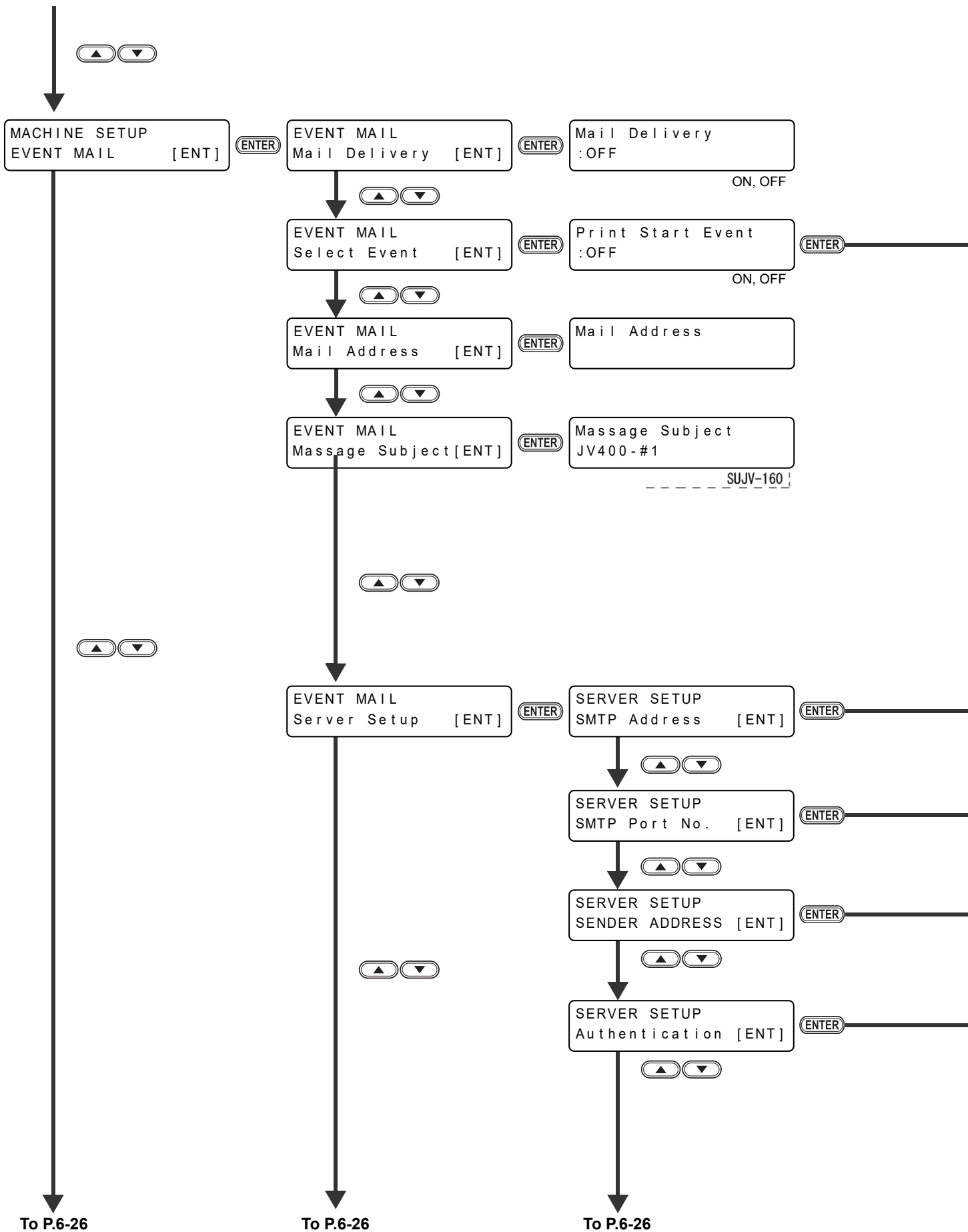

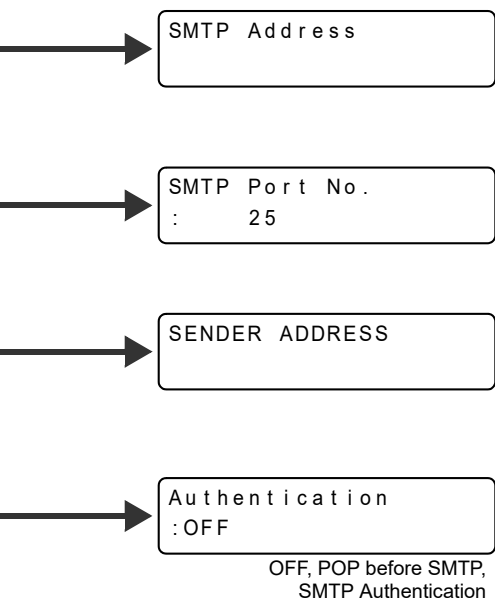
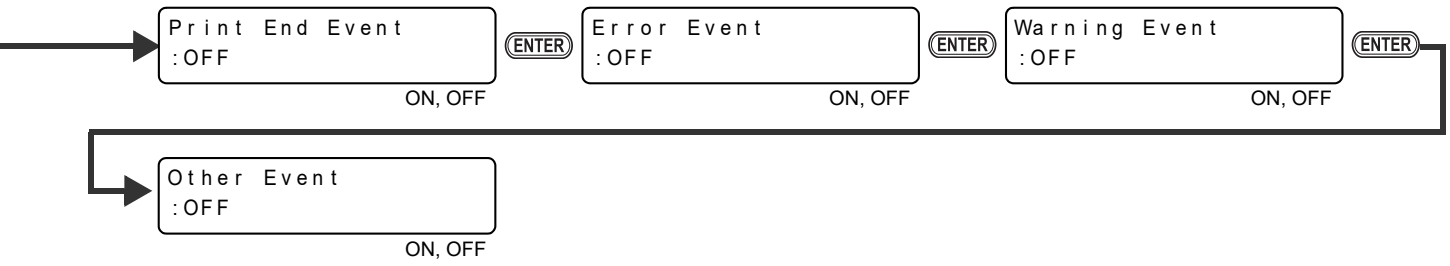

From P.6-24

From P.6-24

From P.6-24

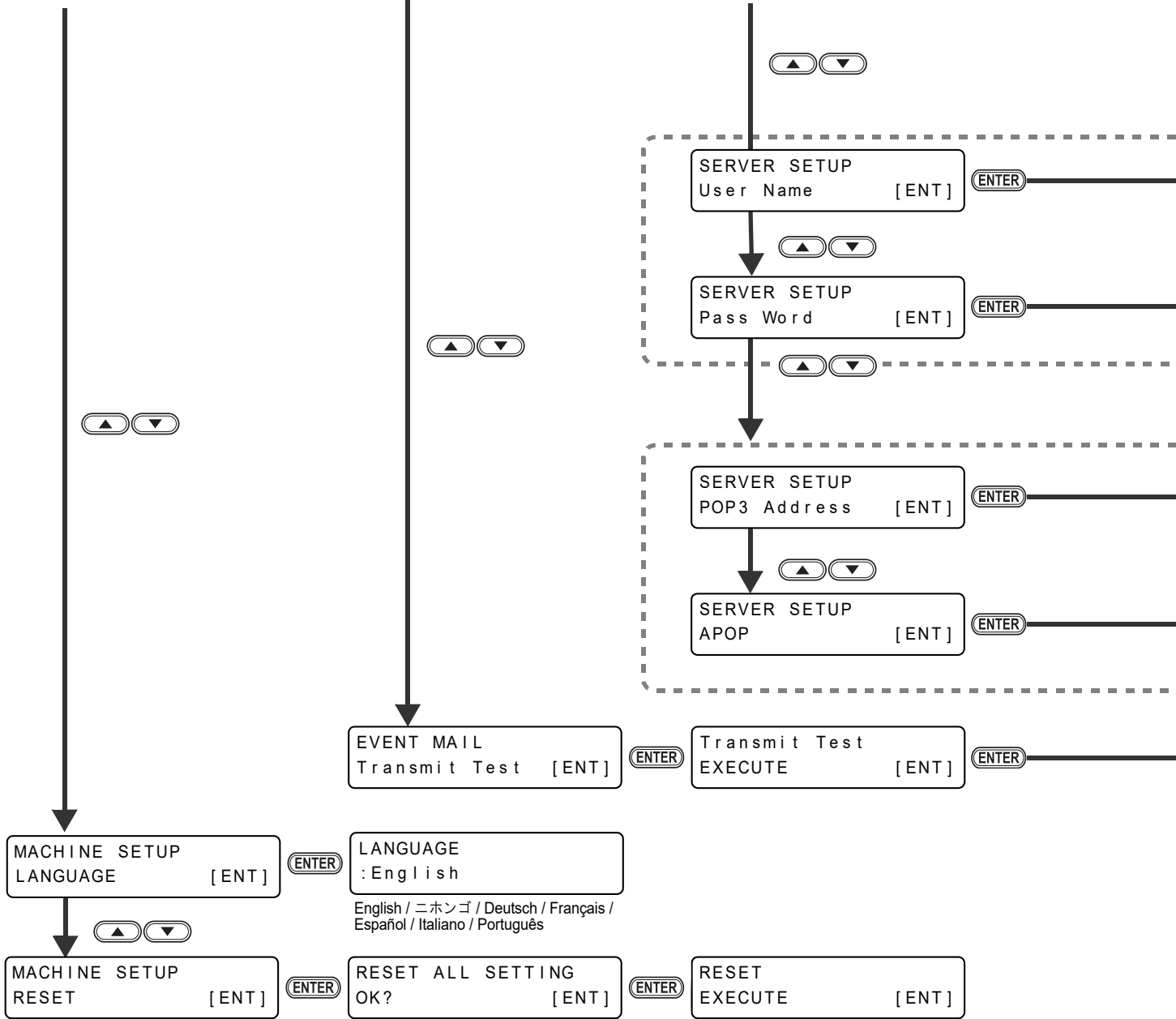



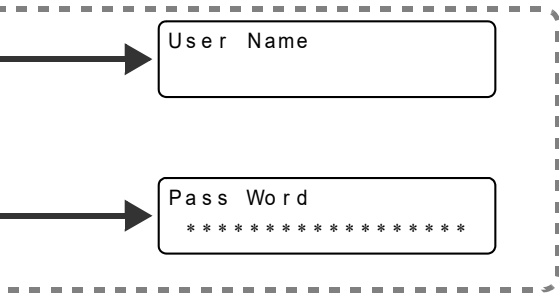

When [Authentication] is [POP before SMTP] [SMTP Authentication], it is displayed.

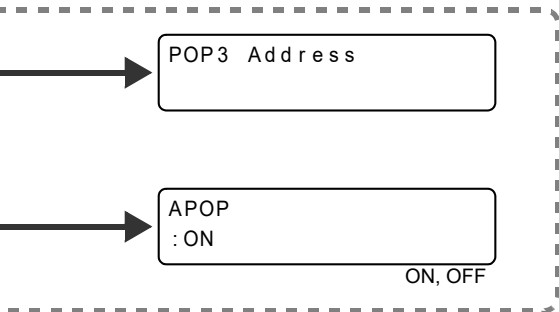

[Only when [Authentication] is [POP before SMTP], it is displayed.

The sent result is displayed.



# **JV400-130SUV/160SUV Operation Manual**

---

---

July, 2020

**MIMAKI ENGINEERING CO.,LTD.**

2182-3 Shigeno-otsu, Tomi-shi, Nagano 389-0512 JAPAN

---

---

D202394-20-30072020

