

OKI

Wide Format Solvent Inkjet Printer

IP-7900-22/23

Basic Operation Guide

Read this User's Guide carefully before use of this printer and handle it properly.
After reading, keep it for later use.



Document number

Introduction

For your basic operation

Maintenance

When encountering a problem

Appendix

ColorPainter H3-104s

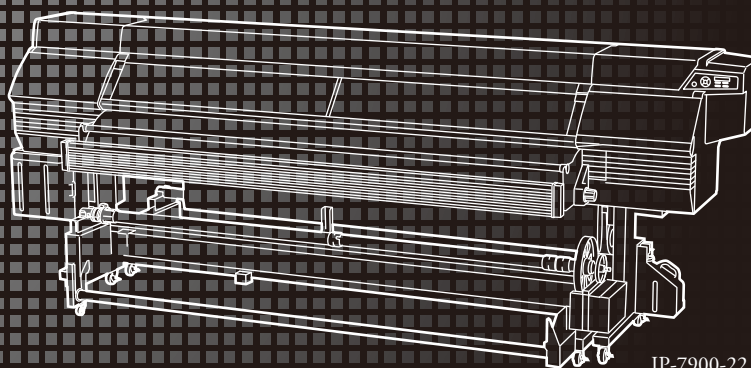

IP-7900-22

Copyright© 2014 Oki Data Corporation.
All rights reserved

Oki Data Corporation. reserves the right to make changes without notice to the specifications and materials contained herein and shall not be responsible for any damages (including consequential) caused by reliance on the materials presented, including but not limited to typographical, arithmetic, or listing errors.

Please address any questions, comments, and suggestions to the regional office on :
<https://www.oki.com/printing/>

This guide acknowledges the following trademarks :
All other trademarks are the properties of their respective companies.

This equipment has been tested and found to comply with the limits for a Class A digital device, pursuant to Part 15 of the FCC Rules. These limits are designed to provide reasonable protection against harmful interference when the equipment is operated in a commercial environment.

This equipment generates, uses, and can radiate radio frequency energy and, if not installed and used in accordance with the instruction manual, may cause harmful interference to radio communications. Operation of this equipment in a residential area is likely to cause harmful interference in which case the user will be required to correct the interference at his own expense.



The CE mark, that shows that the products sold in the EU are conformed to the requirements of EC directive, is statutorily obliged to be affixed to the products.

In each directive, the scope of directive to be applied to equipment is explicitly defined. Our company's product IP-7900 conforms to the EMC directive, low voltage directive and RoHS Directive.

Inquiry of CE mark:

OKI Europe Ltd.

Blays House, Wick Road, Egham, Surrey, TW20 0HJ, UK

Tel: +44 (0)20 8219 2190

Fax: +44 (0) 20 8219-2199

OKI Data Corporation

4-11-22, Shibaura, Minato-ku, Tokyo 108-8551, Japan

Phone: +81-3-5445-6111

Fax: +81-3-5445-6178

Introduction

IP-7900-22/23 Wide Format Solvent Inkjet Printer (hereafter simply called the Printer below.) is equipped with built-in USB interface that adopts solvent ink and supports media of up to 104-inch width.

The IP-7900-22/-23 Wide Format Solvent Inkjet Printer Basic Operation Guide describes:

- The Printer's features and main components
- Information required for the operation
- Basic operations to turn the Printer on and off and to handle the media and ink system

To operate the Printer safely and properly, before starting the operation be sure to read the following.

- **Safety precautions**
- **Delivery products**
- **Manual legend (notation rules)**

Keep this guide near the Printer so that you can quickly access it at any time.

Information described in this guide corresponds to operations with the Printer firmware version 5.00 or later and CP_Manager version 2.70 or later.

How do the two Guides work?

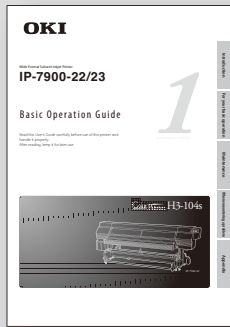

Basic Operation Guide

Read the Basic Operation Guide before your first Printer operation. This guide describes the basic handling and daily operation of media, printing, and maintenance.

To perform your first printing

 **page 24**

To print on other media

 **page 50**

To perform double-sided printing

 **page 56**

To perform the Printer's maintenance

 **page 60**

To replace the Printer's ink cartridge

 **page 129**

To replace the Printer's waste ink bottle

 **page 127**

To recover error messages

 **page 116**

To clear media jams

 **page 115**

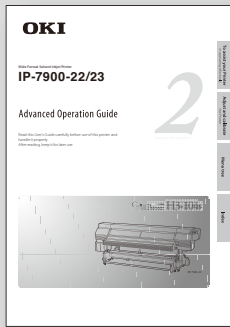

Advanced Operation Guide

Read the Advanced Operation Guide so that you can operate the Printer effectively.

This Guide describes the Printer's fine setting and adjustment to maximize the Printer's performance.

To operate the Printer with fine settings

 **page 74**

To create a new media preset

 **page 26**

To clear banding, white lines, and bleeding

 **page 55**

To turn the Printer off for a long time

 **page 8**

To print on cut-sheet media

 **page 42**

To change heater temperature while printing

 **page 69**

TABLE OF CONTENTS

Introduction	3
Safety precautions	7
Symbol on the printer	7
General warning and cautions	7
Handling precautions	9
Manual legend (Notational rules)	12
Components delivered with this product	15
Operating conditions	17

Introduction 18

Appearance / Main components and their functions 18

Printer rear (supply side)	18
Printer interior	19
Operation panel	20
Printer heater unit	20
Online and offline	21
Online	21
Offline	21
CP_Manager	22
Panel operations	22
Additional functions	22
Supported media	23
Vinyl	23
Banner	23
Mesh banner	23
Backlit banner (FF)	23
Solvent printing coated paper	23

For your basic operation 24

Precautions to prevent media jams	24
Basic operation for printing	26
Printing workflow overview	26
Procedure to remove media roll from the Printer	44
Media at take-up side	44
Media at supply side	47
Procedure to remove scroller flange from media roll	49
To print on other media	50
To print on Vinyl, Mesh banner, Backlit banner (FF), or Solvent printing coated paper	50
To take up media in LOOSE winding mode	52
To perform double-sided printing	56

Maintenance 60

Daily maintenance	60
Start Maintenance	66
Check media wrinkles	66
Perform start maintenance	67
Replace the spittoon case/unit	68
Replace the dust filters	71
Replace the exhaust fan filters	74
Carriage cleaning	77
Clean the exterior (front cover)	79
Replenish spittoon absorber liquid	81
Cleaning the media edge guard	83
Replenish the wiper cleaning liquid	85
Check for dirt or damage on the wiper blade	87
Check the head guard cleanliness	89
Clean the surface of the sensors for automatic print adjustment	92
Clean the capping unit	95
Check the waste ink bottle	98
Performing normal cleaning	99
Print the nozzle print pattern	101
Nozzle map setting	103
After today's operation	104
Sheet mount cleaning	105

When encountering a problem 112



Check your problem	112
How to clear media jams	115
When an error message is displayed	116
Out of ink while printing	121
The media was skewed.	122
Media wrinkles have been detected	123
Warning messages	125
Move the Printer	126
Replace a waste ink bottle	127
Install and replace an ink cartridge	129
Replace a wiper blade	131
Replacing the wiper cleaning liquid	135

Appendix 138

Basic specifications	138
Consumables	139
Options	141
Index	143

Safety precautions

The following symbols are used in the Guides to ensure the Printer's proper operation and to prevent the Printer from being damaged. Follow the instructions marked with these symbols:

 WARNING	Failure to follow the guidelines marked with this symbol could result in serious personal injury or death.
 CAUTION	Failure to follow the guidelines marked with this symbol could result in minor personal injury or damage to the product.

Example of symbols :



This symbol (\triangle) denotes items that require special care while executing a certain procedure or operation.



This symbol (⊘) denotes items that are forbidden.



This symbol (\bullet) denotes items you should follow to prevent accidents or injury.

This equipment is not suitable for use in locations where children are likely to be present.

Symbol on the printer



This symbol denotes locations that may become very hot and that should not be touched.

General warning and cautions

General warnings



WARNING

Be sure to read warnings below before use.



Use the power supply voltage specified on the nameplate. Avoid overloading the printer's electrical outlet with multiple devices.



Be sure the printer is well grounded. Failure to ground the printer may result in electrical shock, fire, and susceptibility to electromagnetic interference.



Always hold the power cord by the plug when connecting and disconnecting from the power outlet.

Never pull on the cord because this may damage it and create risk of fire and electric shock.



Do not use a conversion plug.



Do not disassemble or repair the Printer by yourself. Do not reinstall the printer in a new location. Call your service representative.



DO NOT damage, break, process, or heat the power cable. If it is damaged, replace it with a new one. Using a damaged power cable may cause fire or electric shock.



Power OFF the printer, unplug the power cord from the power outlet, and contact your service representative in any of the following cases. Using the printer continuously in an abnormal state may result in an accident or fire.

- Smoke, strange noise or smell is generated from the Printer or the Printer is overheated.
- There is smoke or an unusual smell coming from the printer.
- The Printer is making an unusual noise during normal operation.
- A piece of metal or a liquid (not part of cleaning and maintenance routines) touches internal parts of the Printer.
- An error requiring service by a service representative occurs.



NEVER use the Printer in a place of extreme humidity or any place where it can possibly be splashed by any liquids. If any liquid gets into the Printer, it could lead to fire, electric shock, or a breakdown.



Do not allow metal or liquids to touch the internal parts of the Printer. Doing so may cause fire, electric shock, or other serious hazards.



DO NOT disconnect or connect the power cord with wet hands. Doing so may lead to electric shock.



Ink used in the ink cartridges and subcartridges is combustible. Do not use or store near open flames, sparks, or other sources of ignition.



DO NOT place the printer on an unstable table or at a slant place. If it falls, it may lead to injury.



Do not touch heater surfaces in the media path. This may cause burns.



Avoid contact between skin, eyes, and clothing and the Printer's following consumables: ink, storage liquid, cleaning liquid, cap cleaning liquid, wiper cleaning liquid, and waste ink.

- Immediately wash skin with soapy water.
- Use an approved eye wash station if ink is splashed into eyes and consult a doctor if necessary. If an approved eye wash station is unavailable, flush eyes with cold water and consult a doctor. Remove clothing soaked with ink from contact with skin.

Do not swallow ink. If swallowed, do not induce vomiting and seek immediate medical attention.



Keep ink cartridges, subcartridges, and waste ink bottles out of the reach of children.

General cautions



CAUTION

Ensure to read cautions below before use.



Operate the Printer carefully near the Printer's movable parts, so that your hands or your clothes are not caught in the Printer.



Install and operate the printer in a well-ventilated area. Otherwise the operator may feel sickish. In such a case, take a rest in a well-ventilated place.



Media rolls and scrollers are heavy. Handle them with care using a dolly or other tools to prevent them from falling. Dropping a media roll could cause personal injury or damage to the printer. Carrying with dolly is recommended.



Be careful not to let ink come into contact with your skin or cloths. If ink touches your skin, immediately wash it off with soap and water.

NOTE

- Make sure the media rolls are secured when stored. They are heavy and may cause injury if they roll or fall.

To ensure safe operation of the Printer, pay attention to all the warnings and cautions contained throughout this manual.

Handling precautions

The precautions below are recommended to avoid damage to the Printer and its components.

Power supply

1. Install the Printer near the socket. To pull out the power plug in an emergency, the power socket must be reached easily.
2. Do not share the power supply with the noise generating devices such as a motor.
3. Use the power supply voltage specified on the nameplate.
4. Monthly turn off the Printer and check the following:
 - The power plug is inserted into the socket securely.
 - No dust is accumulated between the plug terminals and socket. When dust is found, clean the area with a dry cloth.

Printer

1. Do not place anything on the top of the printer. Do not rest your elbows on the Printer. Especially be careful not to block the printer's exhaust outlet shown by the figure below.
2. Do not apply shock or stress to the Printer.
3. During the print operation, do not open the front cover, nor set the pressure control knob to **Open**. Otherwise the printer operation is terminated.
4. Do not clean the cover's surface with benzene or paint thinner. This may damage the Printer's paint. Clean the cover's smear with a soft cloth. If the cover is considerably smeared, wipe it off with a cloth moistened with water-diluted neutral detergent. If it is not cleaned, the smear may affect the Printer's surface painting.
5. Always use the OKI Data specified attachments and options. The other products may degrade the image quality, damage the Printer, and disable the maintenance.
6. Never touch the print head nozzles. They can be easily damaged or clogged.

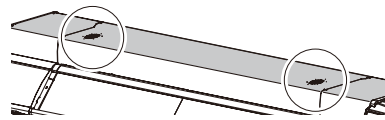

Regular inspection and maintenance

Due to solvent ink characteristics, inspection and maintenance need to be performed periodically. (For details on maintenance, see the Maintenance section starting on [page 60](#).)

1. Perform the start maintenance every day before starting using the Printer.
2. Pay particularly attention to the items below.
 - Regularly replenish the wiper cleaning liquid and spittoon absorber liquid.
 - Once per month, clean the print heads using the sheet mount cleaning kit A (IP7-255).
 - Print heads are highly-precise parts. Do not wipe the nozzle surface directly.
3. If you leave the Printer off for more than 2 weeks, perform the service cleaning.
4. If, after the service cleaning, you leave the Printer for a long time and again you start the print operation with the Printer, be sure to perform the head wash and charge the ink system.

Consumables

1. OKI Data ink cartridges should be installed before the **Install By** date printed on the cartridge. The other ink may damage the Printer, and the Printer repair fee is borne by you.
2. In order to guarantee ink quality, ink expiration dates have been determined. Always use consumables before their expiration date, otherwise they may cause a malfunction.
3. Put used ink cartridges into a plastic bag and dispose of them as industrial waste. Observe local regulations for disposal of consumables.
4. Uncartridge the OKI Data ink cartridge package only when they are installed. Do not store OKI Data ink cartridges in direct sunlight. Store the OKI Data ink cartridges in a cool, dry place. This prevents deterioration of the ink during storage.
5. Do not disassemble the ink cartridges and subcartridges. They are intended for single use only.
6. Do not drop the ink cartridges and subcartridges. Avoid shock to them. The drop or shock may cause an ink leakage.

■ Supported media

The Printer supports the solvent inkjet media of the types below. Note that the print condition may change depending on the environmental conditions and the media production batch. So you are recommended to test the print with the media beforehand.

For details, contact your service representative.

- Vinyl
- Banner
- Mesh banner
- Backlit banner (FF)
- Solvent printing coated paper

■ Precautions on storing media

- ◇ At storing media, packed or unpacked, avoid direct sunlight and water stained. To avoid dust put the media into a box or a bag, and keep it in a cool and dark place.
- ◇ Avoid a rapid temperature change to prevent a dew condensation.
- ◇ Do not store media upright. The media stored upright may be deformed to be telescopic due to its weight, or may deform its edge.
- ◇ Do not pile up the roll media.
- ◇ Make sure the media rolls are secured when stored. They are heavy and may cause injury if they roll or fall.

■ Precautions on disposing of media

- ◇ Dispose of media or printout in compliance with all local, state, and federal regulations.

■ Precautions on using media

- ◇ Do not subject the unpacked media to the temperature and humidity change. Before loading the media on the Printer, leave the media in the operating environment for three hours or more. Note that the ambient humidity change may affect the media by turning on or off the air conditioner.
- ◇ The media may be curled in a lower temperature, and wrinkled in a higher temperature. Keep the temperature around 23°C and the humidity around 50% when you use the media.
- ◇ Do not use a part of media when the part is scratched, wrinkled, turned, or with obstructions. Never use the damaged media, as the right and left edges of the media are especially critical to feed media on the Printer. Besides, do not drop the media and avoid water stained, which may degrade the image quality, and cause the Printer's malfunction.
- ◇ Do not touch the printed image but the margin part. The image quality may be degraded by your insensible sebum and sweat.
- ◇ When the media is wound telescopically at loading on the Printer, correct the slippage before using.

■ Precautions on handling printouts

- ◇ Do not touch the printed surface of the media before the ink dries, or especially 24 hours after printed. Handle the printout by securing the margins.
- ◇ Do not scratch the printout to avoid the color lost or transferred. To avoid the printout's color transferred, do not put the printed media on the other printed media with their printed surface facing each other.
- ◇ Do not put the printed media on the printout from copier or laser printer. The printouts' ink or toner may stick the two printouts.
- ◇ Note that an ink on the printed surface may come off if the surface is rubbed hard or scratched.
- ◇ The printed image may bleed or be lost if the water-stained printout is scratched hard or left.

Other precautions

- ◇ Media loses its color and quality with age. Check the media condition and select the media with better condition.
- ◇ Cut the media carefully, as its paper dust may cause bubble surface at laminated.
- ◇ When adhesive-backed media is applied, some adhesive agent may be left on the platen, which may cause a media jam. So clean the agent completely with a soft cloth moistened with the neutral detergent.

Available area on media

The available area on media in scanning direction depends on media width, media edge guards application, and stripe bar presence. With the media edge guards and stripe bar applied, your available area is decreased by 34.9mm in right and 10.0mm in left. The available are is decreased more when the optional product below is applied:

- Mesh printing kit; or
- Wide type media edge guards for platen sheet

Without mesh printing kit nor wide type media edge guards for platen sheet

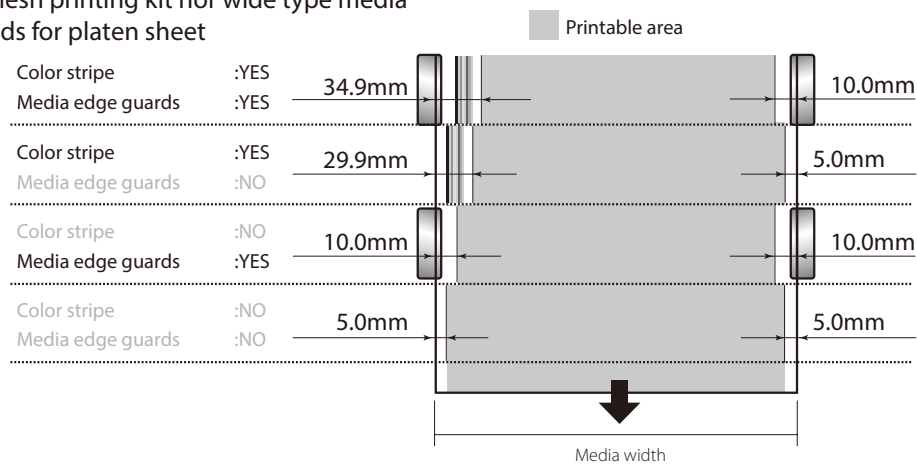

With mesh printing kit

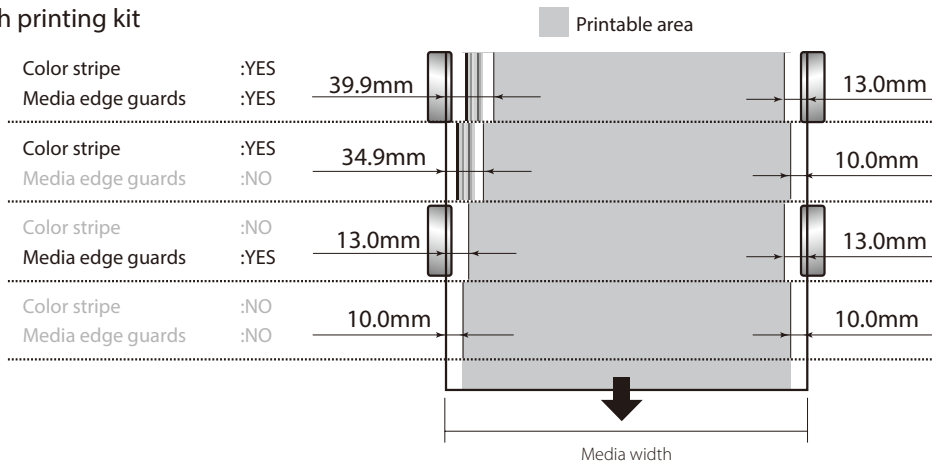

With wide type media edge guards

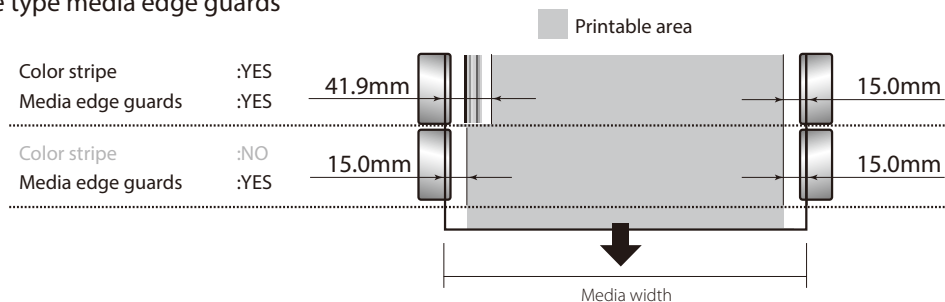

Manual legend (Notational rules)

The notational rules such as marks, buttons, LCD, and LEDs used for explanation in this guide are as follows:

Marks

WARNING

- Boxes marked with a **WARNING** describe points of caution for avoiding serious personal injury.

CAUTION

- Boxes marked with a **CAUTION** describe points of caution for avoiding injury to yourself or damage to the Printer.



TIP:

- This mark indicates useful information, additional items and important operations.



Reference mark

This mark is followed by a reference section or page number.

Capping unit side and wiping unit side

To identify the Printer's right and left, this guide mentions the capping unit side and wiping unit side as follows.

Viewed from the Printer's front
(media take-up side)

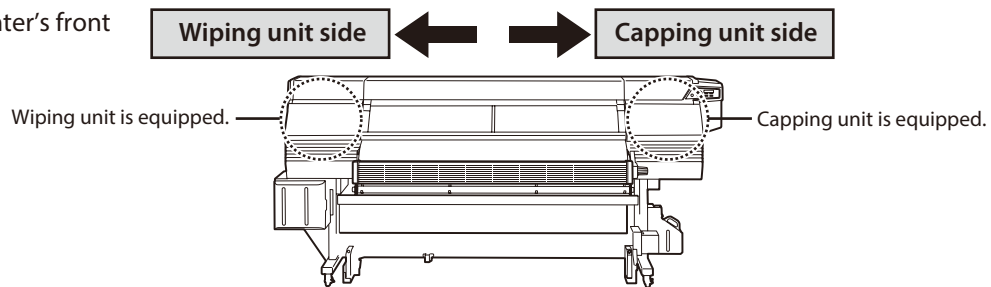

Viewed from the Printer's rear
(media supply side)

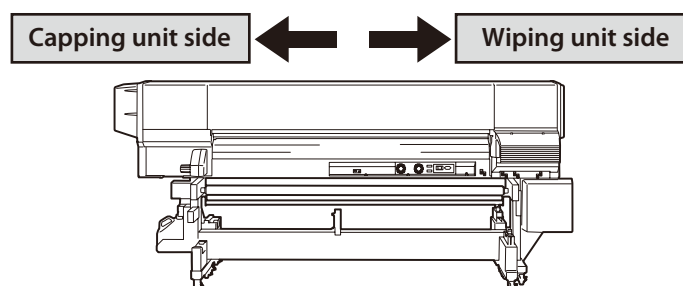

This is the example page for the operation guidance.

Shows the LCD on the operation panel.

Replace the spittoon case.

Operation 1

Required consumables

Replace the spittoon case approximately once every three months depending on the amount of dirt on its surface. If a spittoon lid and a tube set are available when replacing the spittoon case, replace them at the same time. (The IP7-167 includes one spittoon unit and one tube for four spittoon cases.) Replace also the spittoon absorber liquid at the same time.

Replace when:

- You find ink clot accumulated on the spittoon case surface; or
- The net is taken.

When replacing the spittoon case or unit from the operation panel menu, start the procedure from step 1. When replacing while executing #START MAINTENANCE, start the procedure in step 4. You will be prompted to replace the spittoon case or unit during the start maintenance guidance after 3 months or 2.5 km of print length.

1 [REWIND] [FORM FEED] [PH.REC] [PH.MAIN] Press the **Right** button.

2 #START MAINTENANCE With the **Down** button select #MAINTENANCE.

3 #MAINTENANCE > SPITTOON CASE/UNIT Shows that the LCD menu changes in the arrow direction with key operation.

4 OPEN COVER Open the front cover.

5 SPITTOON REPLACED? YES/NO: CANCEL After you have finished the replacement procedure described from step 6, press the **OK** button.

Shows that the LCD menu automatically changes in the arrow direction without key operation.

Remove the knob screw of the spittoon unit and remove the spittoon unit.

CAUTION
The spittoon unit contains cleaning liquid. Be careful not to spill it.

8 Install the new spittoon unit with the knob

Clicking this icon on the PDF displays a video showing the operation.

9 Knob Discharge

Press the knob at the near side of the case containing the spittoon absorber liquid to open the lid, raise the front side of the spittoon absorber liquid case to discharge the spittoon absorber liquid to the backside. The discharged spittoon absorber liquid will go into the waste ink bottle. When discharge is completed, put the spittoon absorber liquid case back into the original position.

CAUTION
Be sure to wear gloves when performing this operation.

Introduction

For your basic operation

Maintenance

When encountering a problem

Operation Guide's quick index
The quick index on the right edge is a shortcut for users to access the target page.

Components delivered with this product

The following components are delivered with the Printer, and installed to the Printer at the Printer installation, check that all the components below are delivered.

If any item is missing or damaged, contact your dealer from whom you purchased the Printer or the nearest service depot.

- **Printer** <1 unit>
 - with USB interface
 - with the feed unit and take-up reel unit

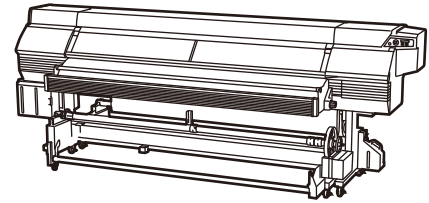

■ Items packed with printer

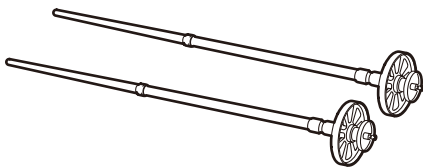

Scroller
<2 pieces>



104-inch paper tube
(for take-up reel unit)
<1 piece>



Paper setting gauge
<1 piece>

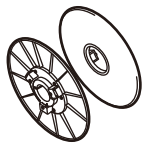

Paper tube flange
<2 pieces>



Rubber spacer A,B,C
<1 piece from each>



Fixing ring
<2 pieces>



Waste ink bottle IP6-109
<1 bottle>

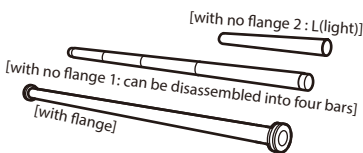

Tension bar
(with flange: 1 piece)
(with no flange 1 S: 2, M: 1, L: 1)
(with no flange 2 L(light): 1)
<3 pieces>



Tension bar flange
<2 pieces>



Tension bar flange with screw
<1 set>



Tension bar joint
<2 pieces>



Phillips screwdriver



Waste liquid bottle
(wiper cleaning liquid)
IP5-299
<1 bottle>

Accessories



Power cable
<2 pieces>



USB 2.0 cable
<1 piece>

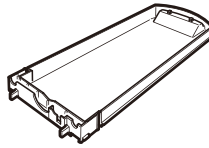

Ink tray
IP7-123
<8 pieces>

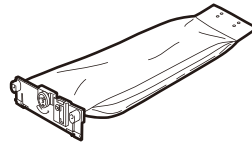

Dummy pack
<8 pieces>

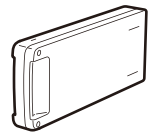

Subcartridge
<8 pieces>

Y, M, C, K, Lm, Lc, Gy, Lgy (one of each color)



Dust filter
<1 roll>

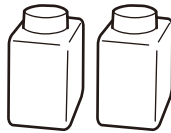

Wiper cleaning liquid A
<1 set>
Wiper cleaning liquid A (300 ml) : 2 bottles



Spittoon absorber liquid A
<1 set>
Spittoon absorber liquid A (300 ml) : 1 bottle



Funnel
<1 piece>

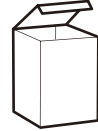

Daily maintenance kit A
IP7-230
<1 set>

- Cap cleaning liquid A: 300 ml
- Wiper cleaning liquid A: 200 ml
- Spittoon absorber liquid A: 100 ml
- Cleaning swab: 10 pieces
- Cleaning swab (Thick): 30 pieces
- Dropper: 10 pieces
- Tweezers: 1 piece
- Spittoon case: 1 piece
- Gloves: 30 pairs
- Bag: 1 piece



Exhaust fan filter
<12 pieces>



Quick reference guide
<1 volume>



Installation procedure guide
<1 volume>



CD-ROM
<1 volume>

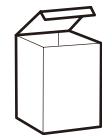

Sheet mount cleaning kit A
IP7-225
<1 set>

Operating conditions

Installation and maintenance space

Adequate space is required around the Printer for supplies replacement of consumables and parts, print processing, and ventilation during normal operation and maintenance. Keep the space shown in the figure below.

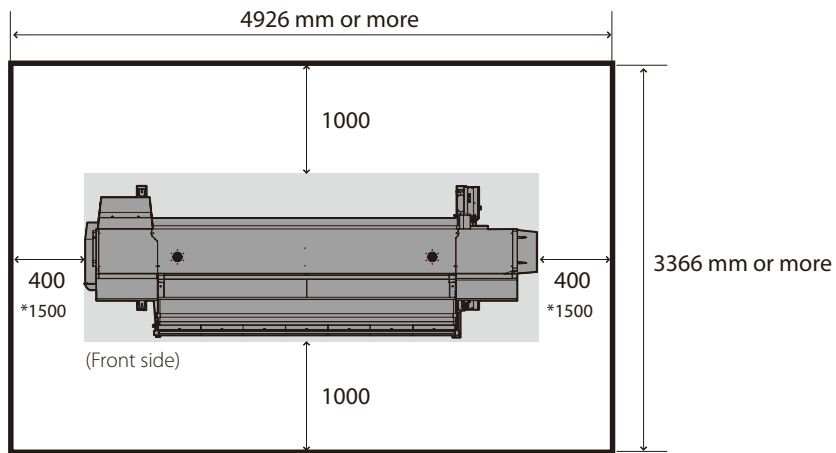

* : Maintenance space

Secure 2200 mm in horizontal direction.
(Unit: mm)

Environmental conditions

■ Operating temperature and humidity levels

Use the Printer within the temperature and humidity levels shown below.

Temperature: 15°C to 30°C (60°F to 80°F)

Humidity: 30% to 70%

- ◇ To obtain better print quality, use the Printer within a temperature range of 20 to 25°C (68 to 77°F). The print speed may decrease when the temperature is below 20°C.
- ◇ To ensure a stable and good print quality, the Printer slows down the print speed when the head temperature exceeds 40°C (104°F).

NOTE

- If the Printer is not used at the operating temperature and humidity ranges, the print may be stopped or the print quality may be degraded.
- It takes time for the Printer to reach the operating environment temperature and humidity.
- To ensure good print image quality, it is recommended to keep the room temperature 20 to 25°C, 68 to 77°F and use the Printer after 1 hour.

■ Places where the Printer must not be installed

Do not install the Printer in the following places.

- ◇ Places near fire
- ◇ Places exposed to direct sunlight
- ◇ Places subject to vibration
- ◇ Places with excessive dust
- ◇ Places subject to extreme changes in temperature or humidity
- ◇ Places near an air conditioner or a heater
- ◇ Places where the Printer may get wet
- ◇ Places exposed to direct exhaust air from an air vent
- ◇ Places near a diazo copier that may generate ammonia gas
- ◇ Places with poor ventilation
- ◇ Unstable places

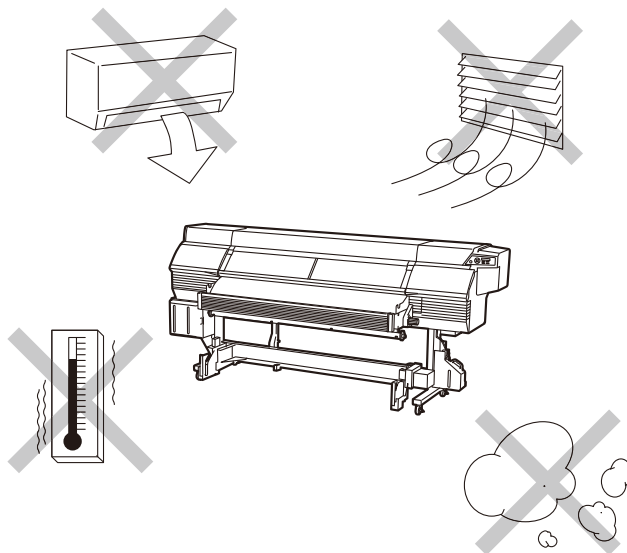



Appearance / Main components and their functions

Printer front (take-up side)

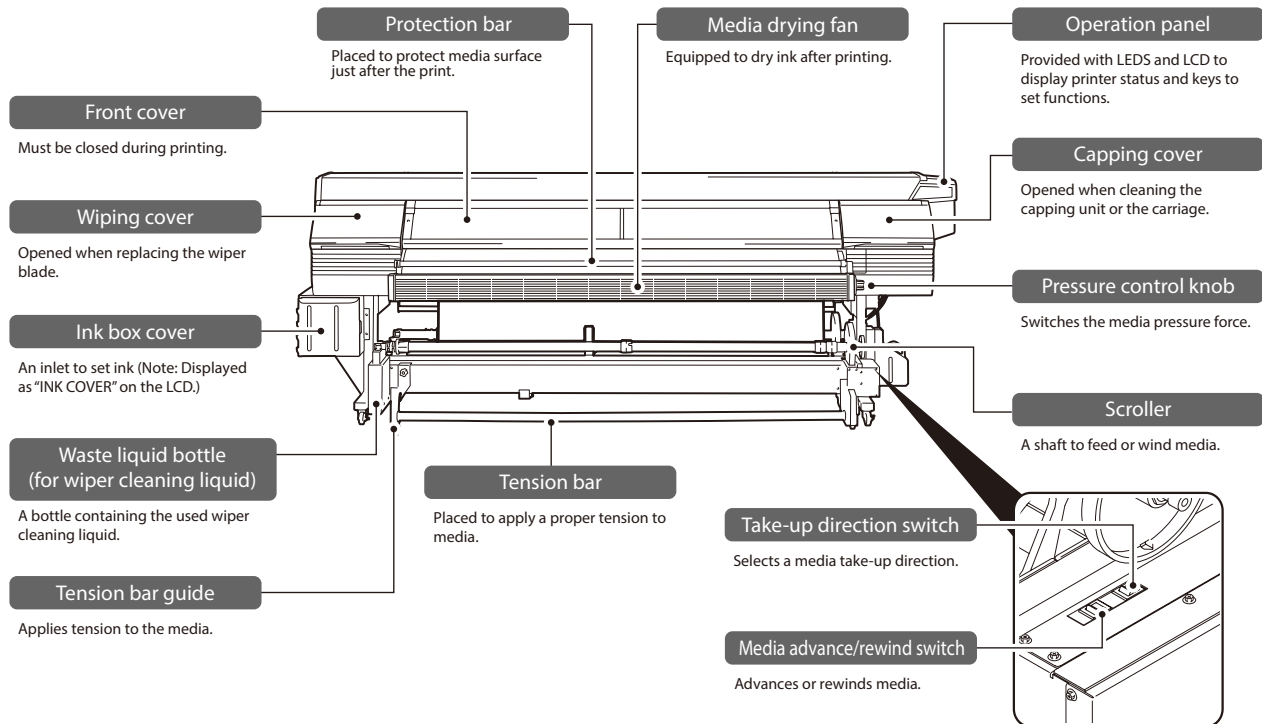

Printer rear (supply side)

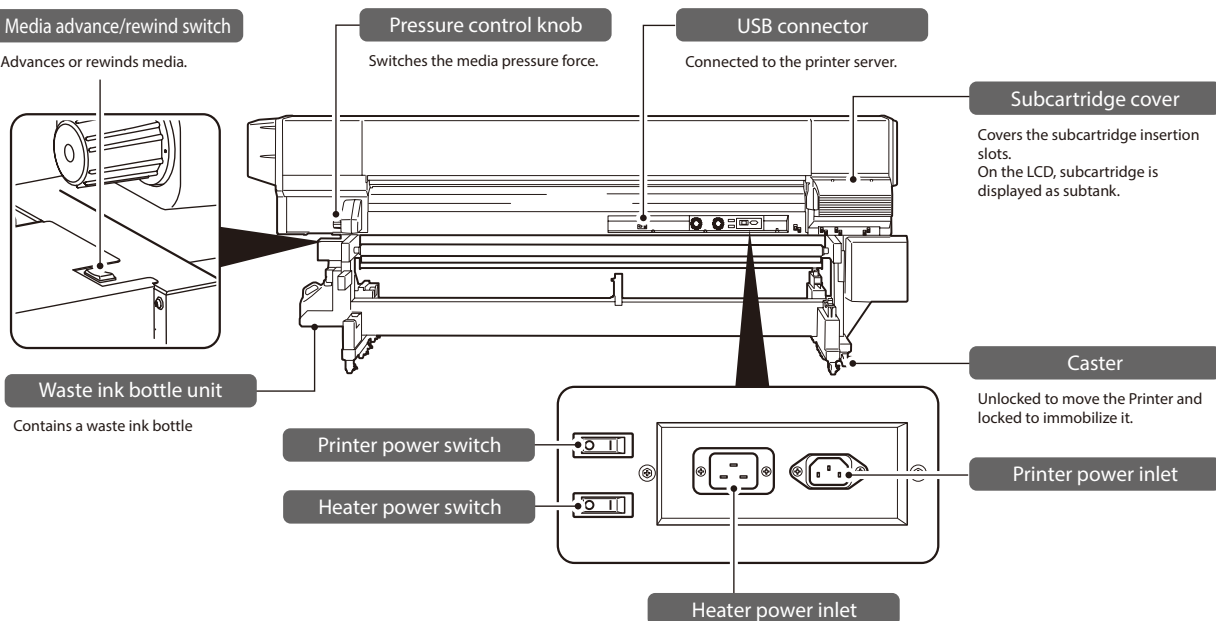

Printer interior

Wiping unit
Removes foreign substances on the print head's nozzle surface.

Carriage
Houses the print heads inside, and prints image with scanning media.

Capping unit
Prevents the print head's nozzles from drying.

Spittoon case
For the stable printing, contains the absorbers to hold excess ink from print head.

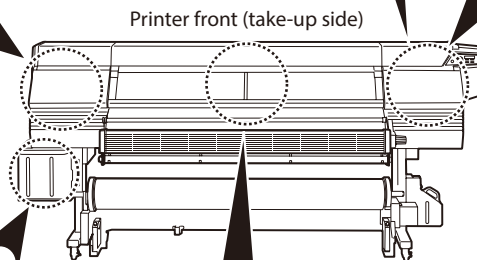

Ink tray
Supports ink cartridge setting.

Media edge guard
Protects print heads from being damaged by the curling or feathering media edge.

Platen
Transports media. The platen incorporates suction fans and print heater to cure the ink.

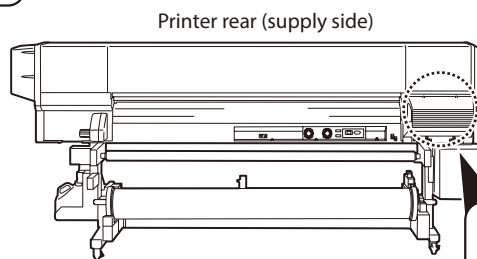

Subcartridge
Provides with ink for printing while ink pack is replaced. On the LCD, Subcartridge is displayed as subtank.

CAUTION

Be sure to unlock the stopper before closing the wiping cover and capping cover.

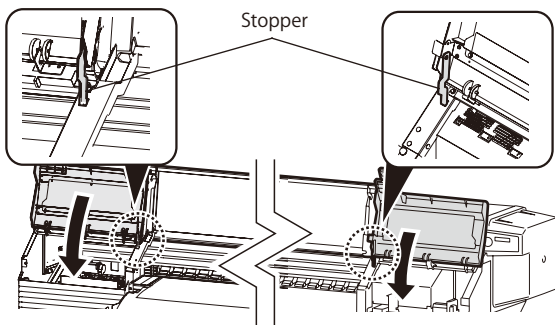

Operation panel

The buttons, LEDs and LCD are laid on the Printer's operation panel of the Printer as shown below. In addition, the operation panel is also equipped with a buzzer function for attention in case an error occurs or an invalid button is input.

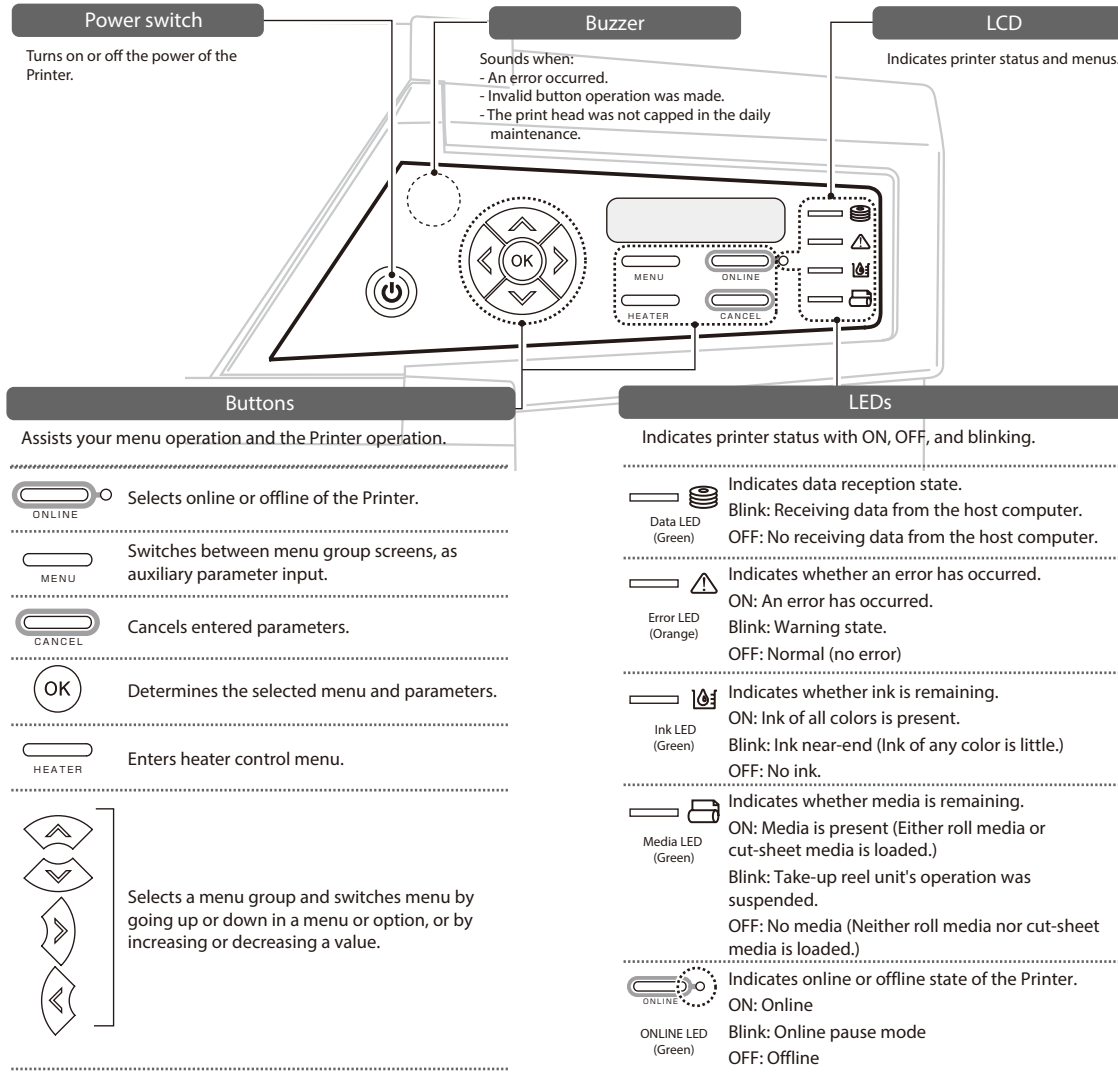

Printer heater unit

The printer is equipped with three heaters for ink fusing and image quality stabilization.

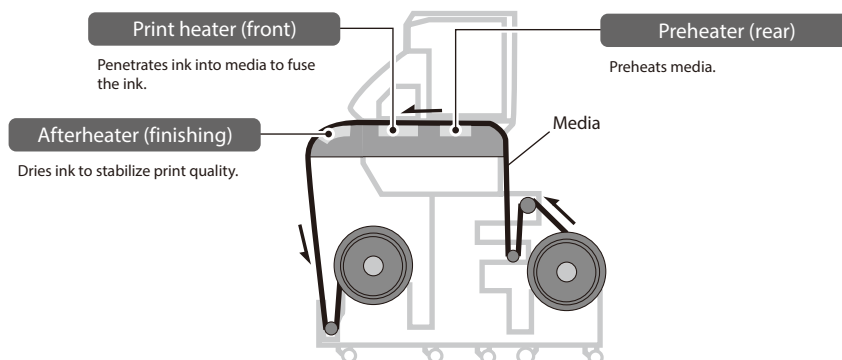

* These three heaters are controlled independently.
The temperature of the heaters can be controlled from the operation panel, the RIP software and Cp_Manager.

WARNING

- Do not touch these heaters to avoid burn as they become hot.

Online and offline

The Printer operates in both online and offline.

When the Printer is in online:

- The Printer prints the data sent from the computer's Raster Image Process (RIP) software.

When the Printer is in offline:

- The menu is operated with the operation panel buttons.

The **ONLINE** button switches between online and offline.

Online



When the online LED is on, the Printer is online.



When the data LED is on, the Printing.

Offline



When the online LED is off, the Printer is offline.

Online state (idle mode) display

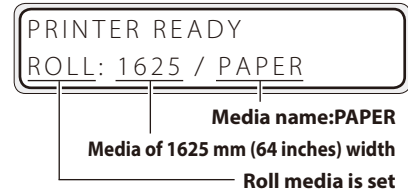

- Print mode
 - MAX-SPD: Maximum print speed
 - HI-SPD: High print speed
 - NORMAL: Normal use
 - HI-QUA: High print quality
 - MAX-QUA: Maximum print quality
- Smart pass
 - L: Low
 - M: Medium
- Print direction
 - BI: Bidirectional
 - UNI: Unidirectional
- Density
 - ND: Normal density
 - HD: High density

The Printer in offline displays the menu group on the LCD, and activates the menu operation.

The menu operation assists you to create new media presets, perform daily maintenance, and adjust the print head settings.

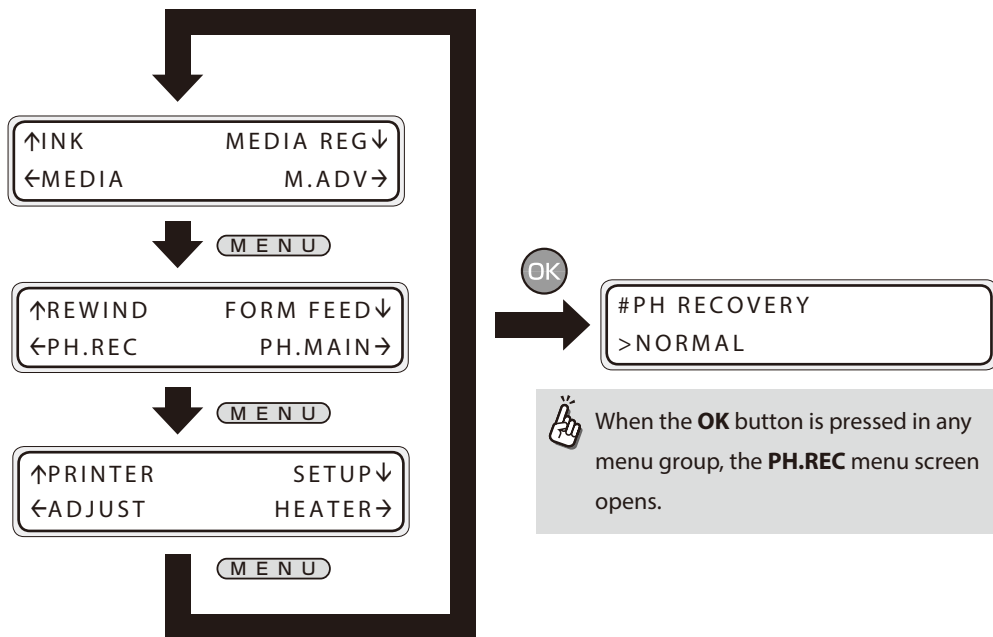

When the **OK** button is pressed in any menu group, the **PH.REC** menu screen opens.



When an operator call error is displayed...

- To activate the menu operation, press the **ONLINE** button.
- * However, in some cases the **ONLINE** button does not activate the menu operation.

CP_Manager

The Printer supports the CP_Manager software that provides a general view of the Printer status. The following operations can be performed with CP_Manager™.

Panel operations

- Display Printer status
- Create media preset, input adjustment values
- Execute nozzle printing, adjustment patterns printing
- Maintenance time notice, maintenance operation.

Additional functions

- Display the instruction manual (PDF)

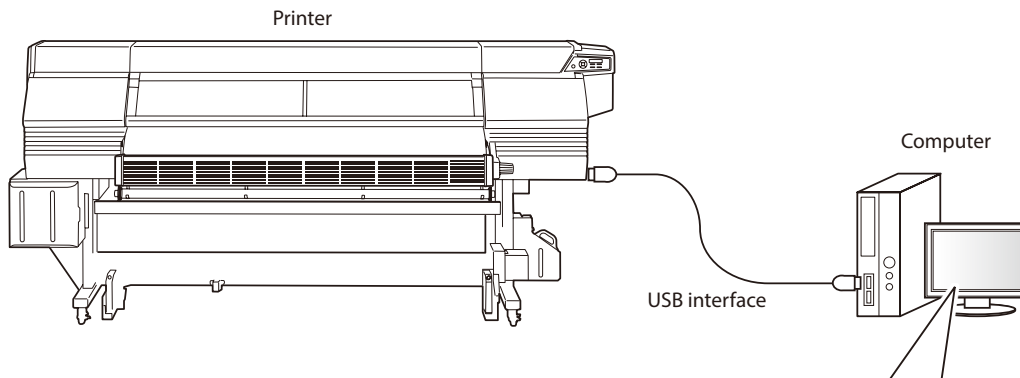

CP_Manager display example

The screenshot shows the CP_Manager software interface. On the left is a 'Printer status display' panel with a green 'ONLINE' indicator, a 'PAPER' section showing 1625 mm and 0 m, and a 'Heater' section with three 'OFF 20 °C' indicators and a temperature gauge. The main area is titled 'Media preset' and contains various settings for 'PAPER' media, including 'Advance Value Priority', 'Media Advance Value', 'Print Mode Priority', 'Smart Pass', 'Density', 'Print Direction', 'Heater Temperature Priority', and 'Bidirectional Adjustment' settings. A 'Copy Media Preset' section is also visible at the bottom right.

Install CP_Manager™ using the CD-ROM supplied with the Printer.

Supported media

Vinyl

Vinyl is media with PVC-material surface. As a general vinyl is adhesive-backed, by peeling the release paper on the back you can stick the media easily. Depending on its gloss grade, the vinyl is classified into three: glossy vinyl (with high gloss), matte vinyl (with no gloss), and semi-glossy vinyl (with medium gloss).

When the media is applied on some prints, a gray adhesive-backed vinyl is effective to avoid the prints seen through the top media.

For backlit purpose application, the PVC material surface is sometimes transparent or translucent.

Banner

Banner is polyester fiber cloth media with double sides coated with synthetic resin film such as PVC. As the banner is water- and tear-resistant, it is applied for tent canvases, construction wrap sheets, and inkjet-printed banner advertisements.

Depending on its gloss grade, the banner is classified into three: glossy banner (with high gloss), matte banner (with no gloss), and semi-glossy banner (with medium gloss).

Mesh banner

Mesh banner is perforated banner media reinforced with mesh grid. As its open structure allows wind to permeate, the mesh banner is wind- and tear-resistant, and will withstand heavy wind.

Depending on the absence of liner, ink absorbing back sheet, the mesh banner is classified into two: backed and unbacked. Though the backed mesh banner is applied to a usual printing, the unbacked mesh banner requires the optional mesh printing kit.

Backlit banner (FF)

Backlit banner, flexible face (FF) is translucent, that is, semi-transparent banner media. With its translucency, it is applied to the backlit sign inside a light box.

Compared with an acrylic sign, the backlit banner is lightweight and easy to handle, wind- and tear-resistant, and of high safety and shutter proof withstanding wind pressure.

Solvent printing coated paper

Solvent printing coated paper is media with the printing surface coated on which solvent ink is cured vividly. Its thickness depends on the product type.

When the media is applied on some prints, a blue back type is effective to avoid the prints seen through the top media.



Precautions to prevent media jams

The precautions below are recommended to prevent the main causes of media jams: media wave and skew.

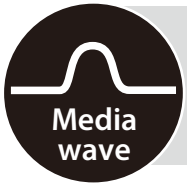

If media waves, the sliding carriage may touch the wave, which may damage the Printer.

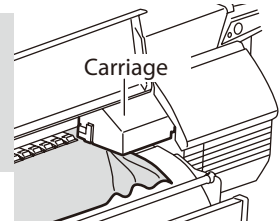

At printing without winding

Note that the media on the platen may bunch up when the front media edge reaches the floor.

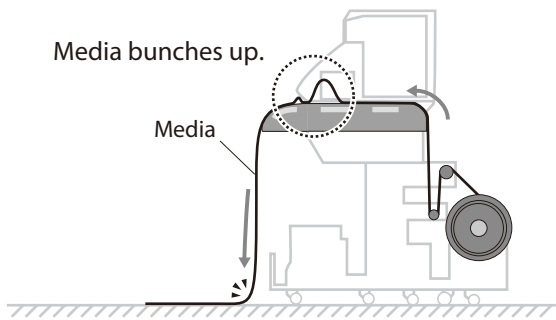

At printing on paper-based media

To avoid media wrinkle, turn off the preheater and printhead.

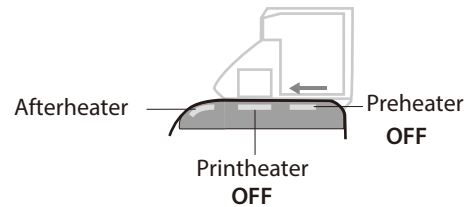

At setting media

Set the media so that the front media edge precedes the front cover.

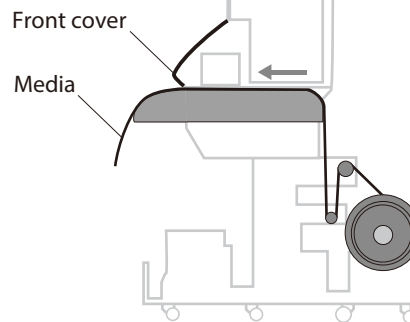
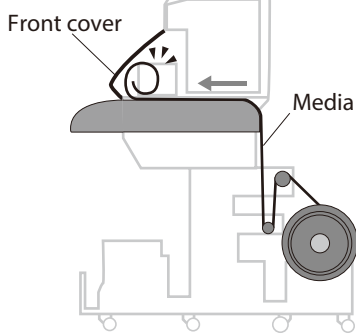

At visually checking media

Avoid using the media below.

The media was wound telescopically.

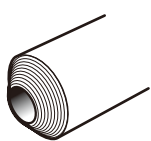

The right or left media edge curls.

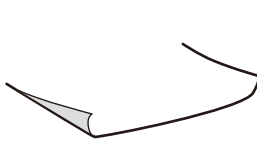

The media edge is deformed by, for example, hitting media

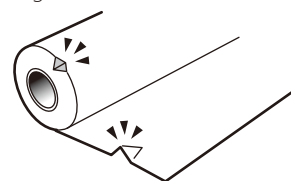



If media skews, the media edge is disengaged from the media edge guard, which may cause the media wave.

[Viewed from top]

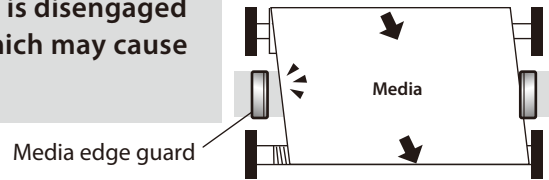

Set the tension bar at the media center.

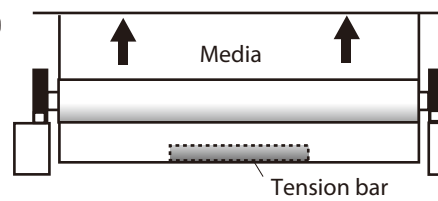
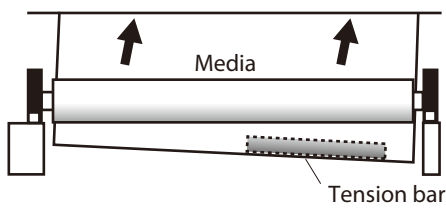

At fixing media to the take-up paper tube, Stick the adhesive tape from center outward.

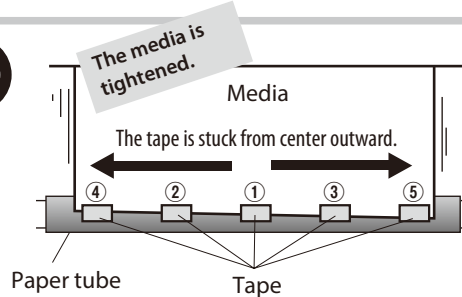
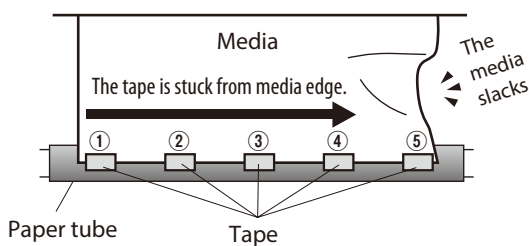

At attaching media to the take-up paper tube, Be sure to set the media perpendicular to the take-up paper tube.

If the media is not perpendicular to the paper tube, the media is taken up with skew, which may cause the media wave on the platen.

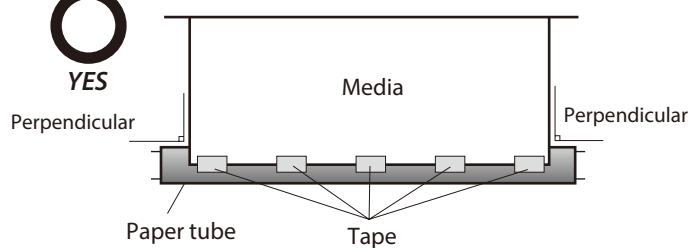
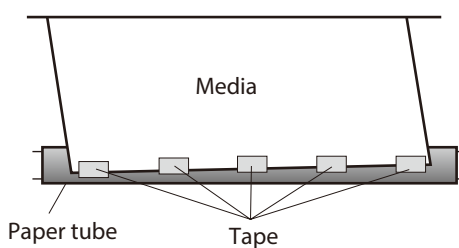

At taking up media in LOOSE winding mode

Be sure to take up media with paper tube flange. Without paper tube flange, winding deviation may cause a media jam.

Paper tube flange

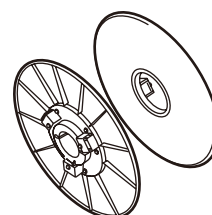

Basic operation for printing

! CAUTION

- Pay particularly attention when handling heavy components. (See  page 8 for details.)

Printing workflow overview

1

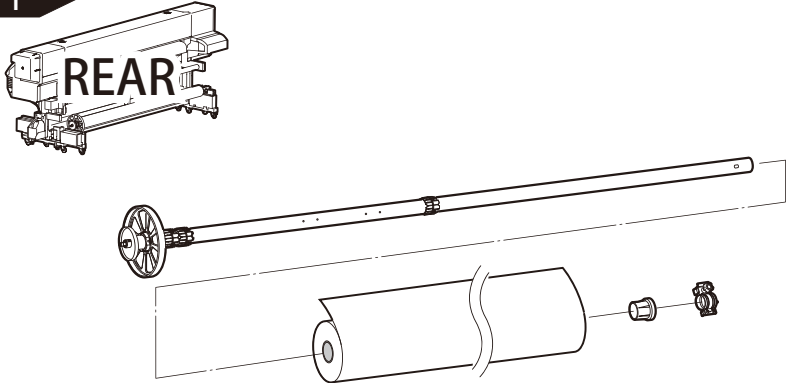

REAR

2

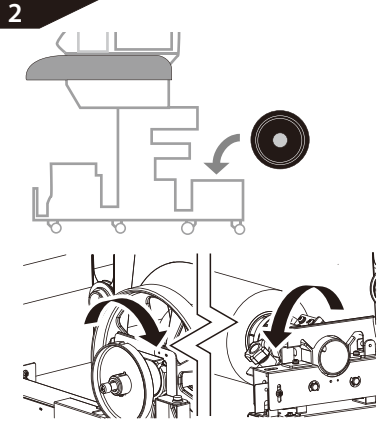

3 FRONT

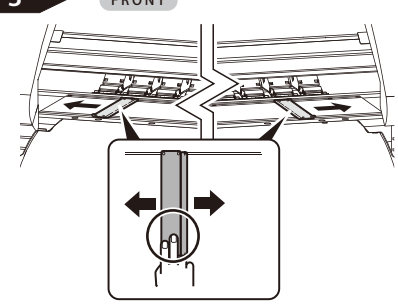

4

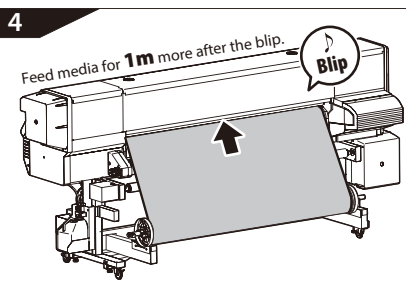

5

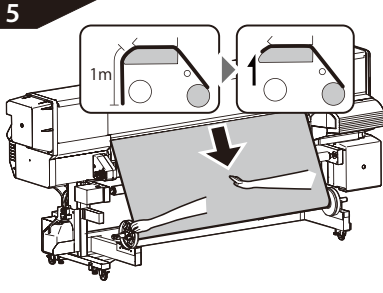

6 FRONT

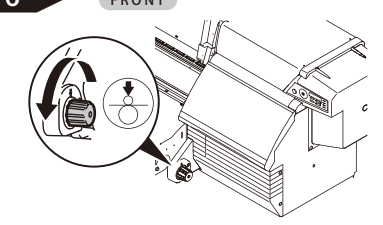

7 FRONT

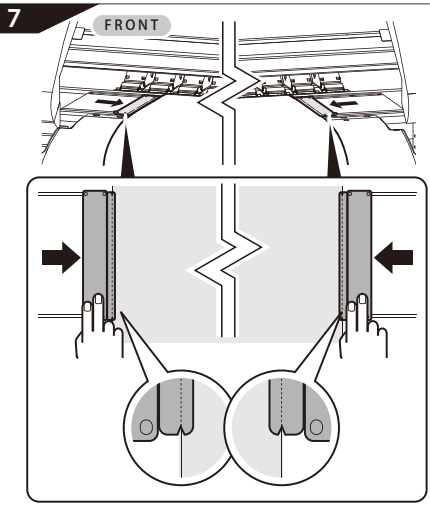

8 FRONT

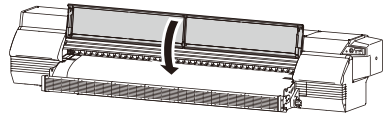

9 FRONT

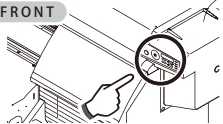

CHECK EDGE GUARD
* OK?

OK

SELECT MEDIA
ROLL/SHEET:ROLL

OK

SELECT MEDIA
MEDIA:PAPER

✓ ...

SELECT MEDIA
MEDIA:Banner

OK

SET REMAINING MEDIA
*** m

OK

CHECK
SLACKEN MEDIA

10

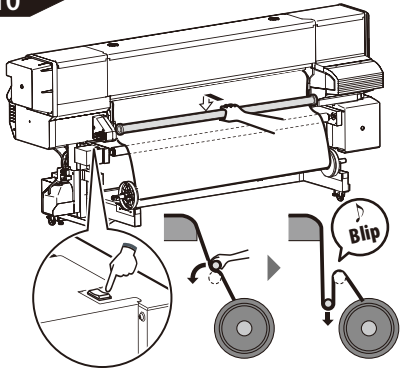

11 FRONT

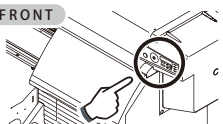

SET MEDIA
* OK?

OK

PREPARING MEDIA
PLEASE WAIT

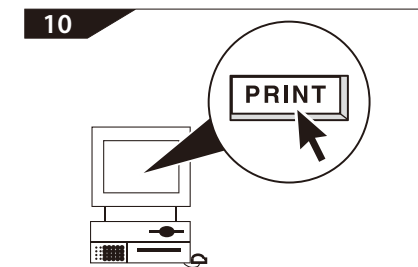
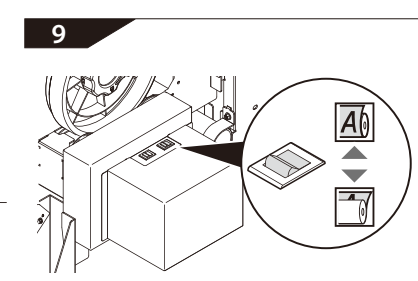
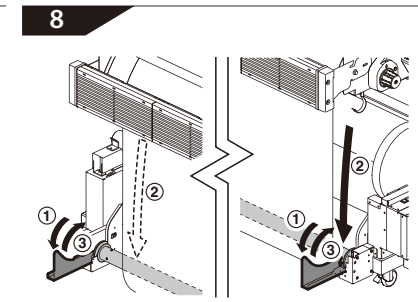
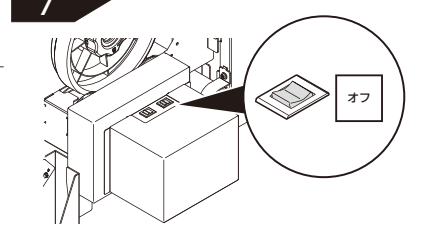
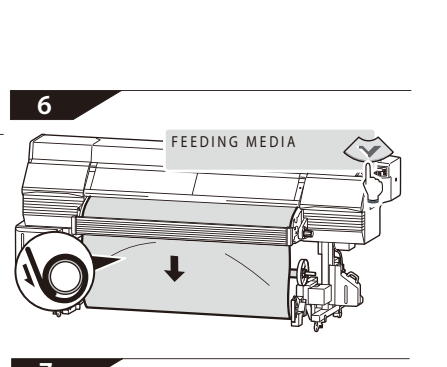
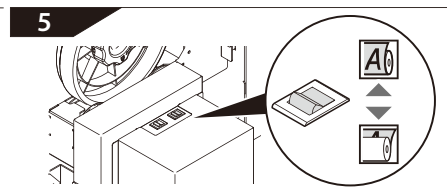
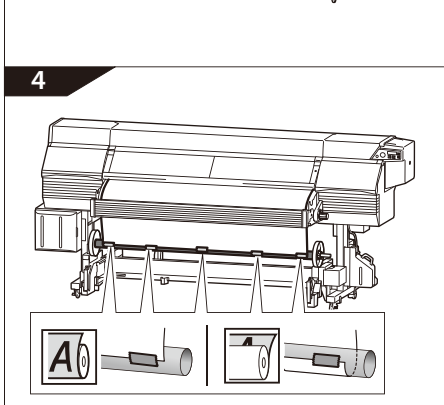
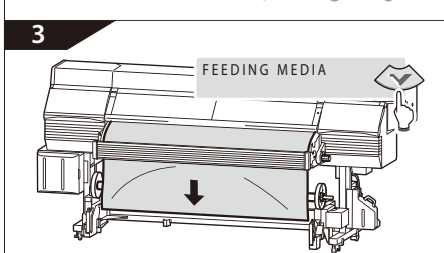
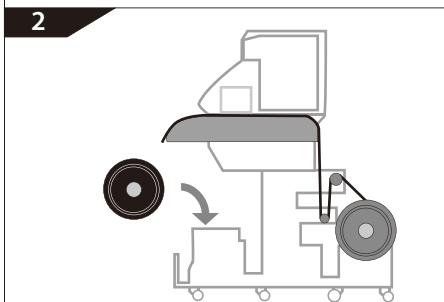
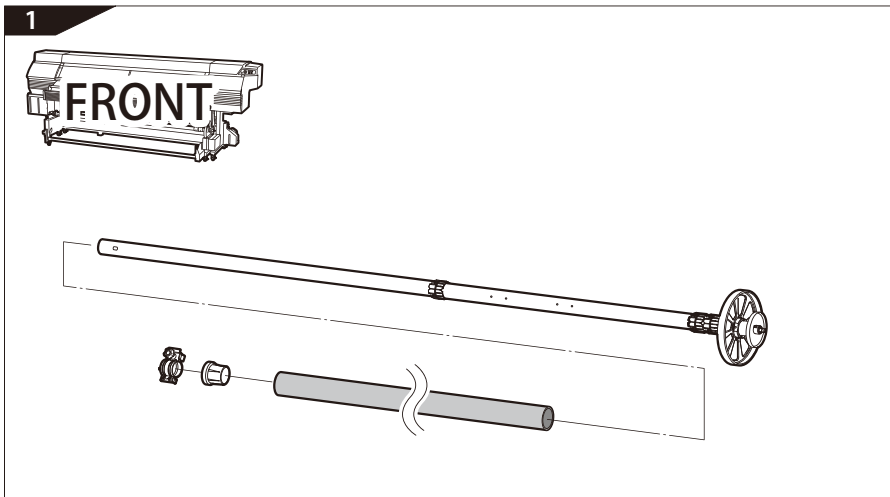

● To connect USB cable

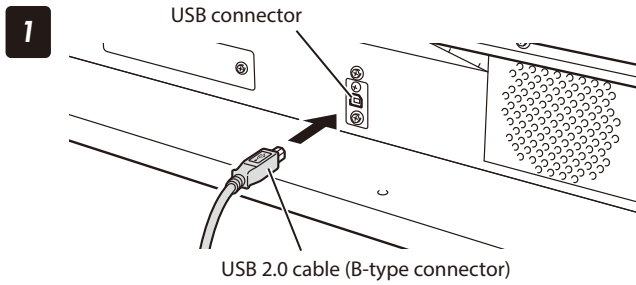

Connect the Printer's USB 2.0 cable to the USB connector at the rear center of the Printer.



Important!

- Use the supplied USB 2.0 cable.
- For the USB connection and the related system, use the USB-compliant hubs and cables supporting USB 2.0. Note that a normal operation may not be ensured if the hubs, cables, and the other related devices are not USB-compliant.
- Use 5m cable or shorter. If the connection length exceeds 5m, apply hubs to extend the connection. The hub quantity must be five or less in total. Note that a normal operation may not be ensured if a cable exceeding 5m is applied, or if the cable connection exceeds 5m without hubs.

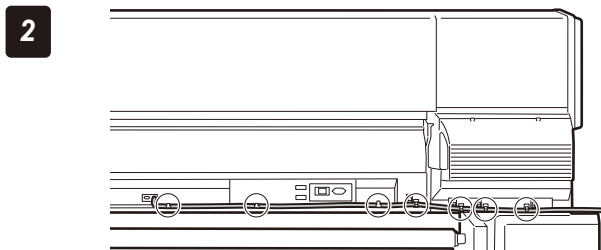

Clamp the USB 2.0 cable to the Printer along the wiping unit direction.

Be sure to clamp the USB cable on the Printer's wiping unit side to:

- Protect the USB connector
- Prevent the media feed sensor's incorrect detection

● Turn the Printer on

With the procedure below, supply the power to the Printer's two 200V power system.

CAUTION

- Do not use any power cable other than those supplied with the Printer.
- The supplied power cables are for 200 VAC only. Note that the plug shape differs from that for 100 VAC.
- Be sure to secure the power cables with cable clamps. Otherwise, they may be caught by the feed unit resulting in electric shock or damage to the Printer.

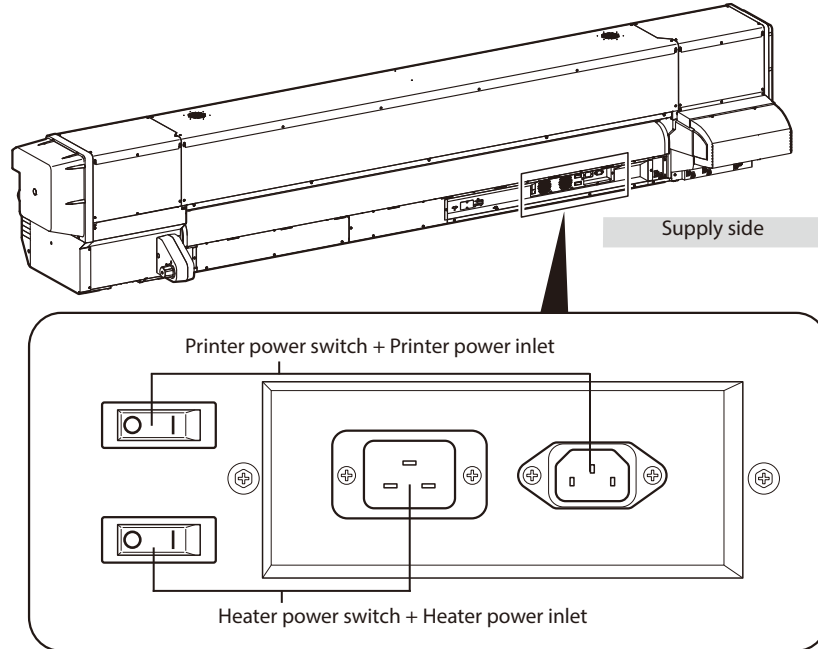

Turn the printer power and heater power switches on only before your first operation. From the next operation, turn the Printer on and off only by pressing the POWER switch on the operation panel.

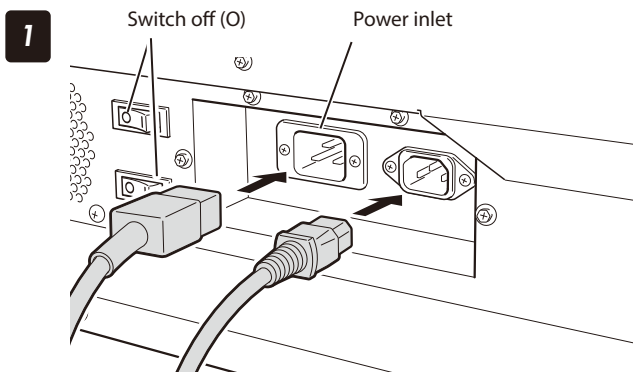

With the two power cords supplied with the Printer, connect the Printer's two power inlets and the power supply's two sockets.

Be sure to confirm that at the rear of the Printer the printer power switch and heater power switch are set to off, the side marked with O.



Clamp the two power cords to the Printer.

To protect the power cords, be sure to clamp them.

3

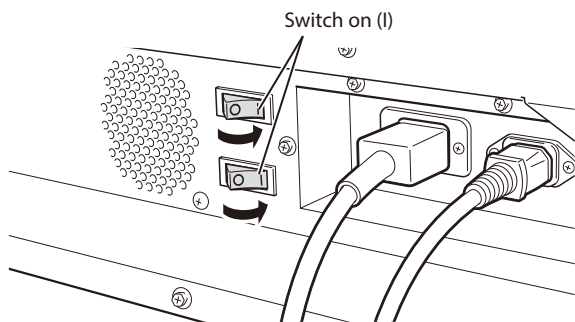

Set the printer power switch and heater power switch to on, the side marked with I.

4

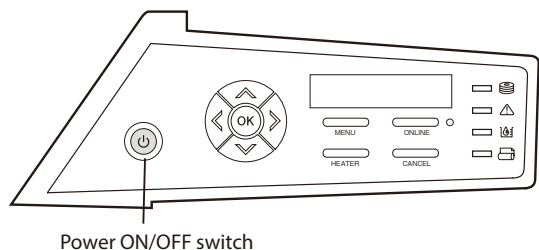

Press the power switch on the operation panel.

When the power switch is turned on, the Printer performs the power-on self-diagnostic test and displays the following message on the operation panel.

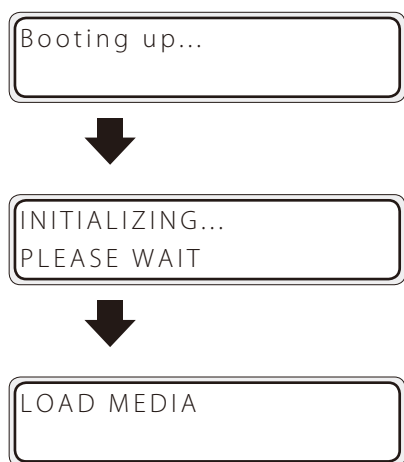

If an error message appears...

- To recover the error, refer to *When encountering a problem*.
- If the POWER LED on the operation panel does not light even when the printer and heater power switches at the rear of the Printer and the power ON/OFF switch on the operation panel are turned on, the power supply has a problem.

CAUTION

Except for emergency, turn off the power while a message **PRINTER READY** is displayed. If the power is turned off unnecessarily when the Printer is performing **INITIALIZING...** or **CLEANING**, the ink may drool, the print head may be damaged, or saved parameters may be lost.



● To turn the Printer off

1 SHUTTING DOWN
PLEASE WAIT

To turn off the power of the Printer, keep the power switch on the operation panel pressed for 2 seconds.

The message shown above is displayed on the LCD to indicate that the shutdown process is being executed. The power turns off after the shutdown procedure is finished.

However, maintenance operations are automatically performed to maintain the Printer in good condition. Therefore, always keep the power of the Printer on.

If you need to temporarily turn the Printer off in case of emergency, for cleaning, or other reasons, use one of the following methods to turn it off.

Method 1: Keep the power switch pressed for 2 seconds.	Usually, use this method to turn the Printer off. During shutdown, the fill cap operation (state where the caps are filled with ink) is performed to keep the print heads in good condition.
Method 2: Keep the power switch pressed for 2 seconds while holding the CANCEL button.	This method can be used to turn the Printer off only for a short time (less than 1 hour). With this method, the fill cap operation is skipped and the Printer is turned off.

CAUTION

- After turning the power off, wait at least 5 seconds before turning it back on.
- To keep the print heads in good condition, the printer perform automatically and periodically the fill cap operation while in standby mode.
It is recommended to keep on the power switch on the operation panel.

● To load media on the Printer

This section uses banner to explain the media loading procedure.

CAUTION

- Media rolls and scrollers are heavy. To prevent injuries, lifting of these components should always be performed by two or more persons and attention must be paid not to let them fall. Additional persons may be required if these components seem to be too heavy. Lifting objects that are too heavy may lead to physical injuries.
- To prevent injuries when loading or replacing the media, use a dolly equipped with a lifter (recommended dolly).

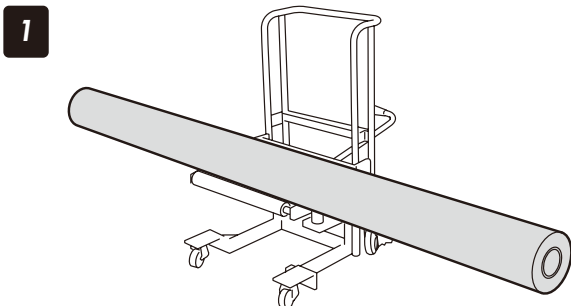

Put the media on the table.

If you intend to use a dolly, contact us. We have a recommend product.

2 Load a roll media onto the scroller flange and scroller shaft.

CAUTION

- Do not grab this roll spacer as it has several protrusions.

Remove the two screws and move the roll spacer to the center of the media. There are three screwing positions.

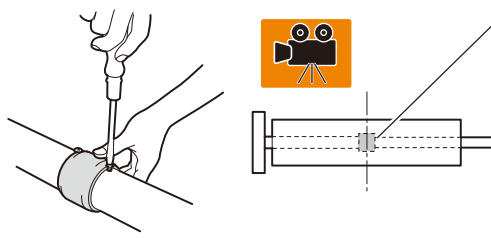

Roll spacer

The roll spacer prevents the paper tube from bending at the center due to the media weight. Move it when using media that tends to bend (100-inch media, etc.). Move it also if it comes in the way of the flange spacer used with media short in width.

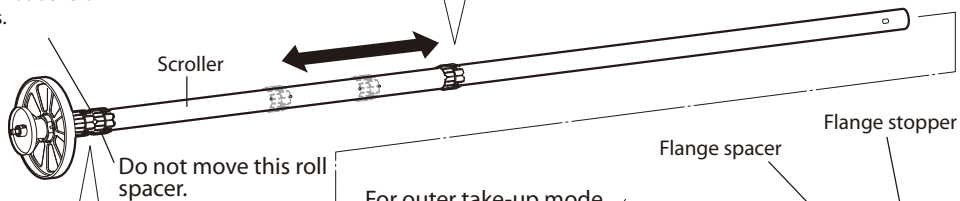

Insert the scroller into the paper tube, determine the distance between the media edge and the flange.

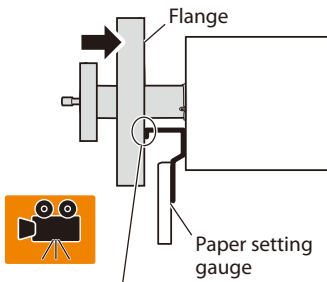

Attach the paper setting gauge's flange side to the flange's spoke side.



Rotate the handle clockwise as far as it will go, and then secure the scroller at the point.

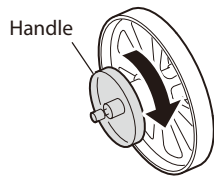

Roll spacer Scroller

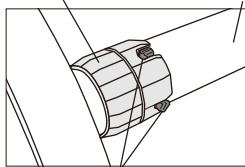

CAUTION

- Do not touch the claw of the scroller.

For outer take-up mode

For inner take-up mode

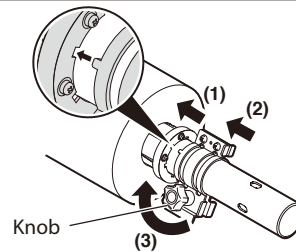
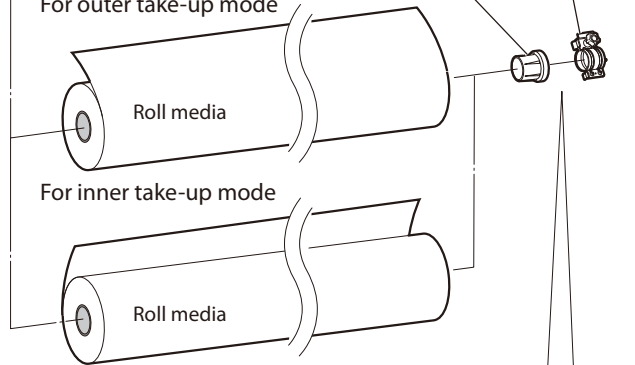

- (1) The flange spacer has teeth. Push it as far as it will go.
- (2) Match the flange stopper with the claw of the flange spacer

CAUTION

- Hold the knob to move the flange stopper. Holding another part to move the flange stopper may lead to injuries.
- (3) Tighten the knob to secure the flange spacer and the flange stopper.

3

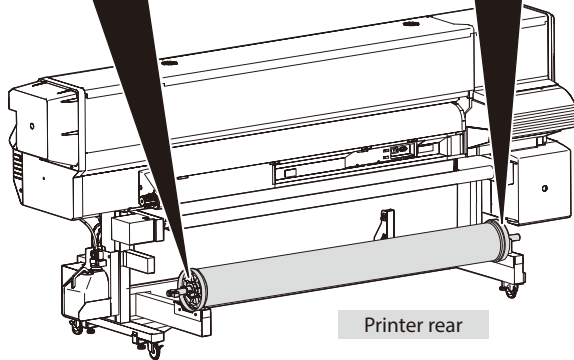
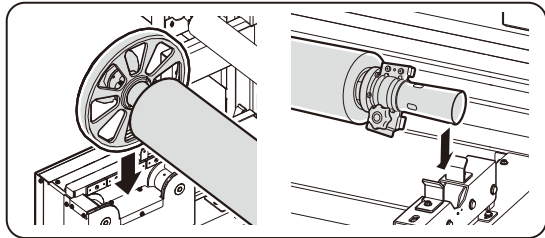

Load the media roll into the Printer's rear side (supply side).

CAUTION

- Be careful not to trap your hand or fingers between the Printer and scroller shaft.



CAUTION

- Media rolls and scrollers are heavy. To prevent injuries, lifting of these components should always be performed by two or more persons and attention must be paid not to let them fall. Additional persons may be required if these components seem to be too heavy. Lifting objects that are too heavy may lead to physical injuries.
- To prevent injuries when loading or replacing the media, use a dolly equipped with a lifter (recommended dolly). If carried by hand, hold the media by the scroller shaft.
- Be careful not to catch your finger or hand between the Printer and the scroller shaft.

On carrying the media alone:

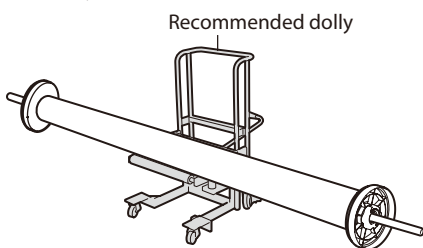

When carried by two or more persons

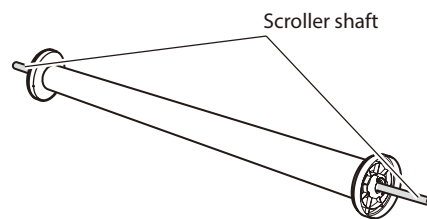

4

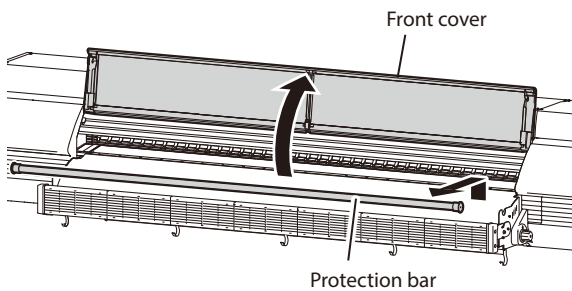

Remove the protection bar and open the front cover.

5

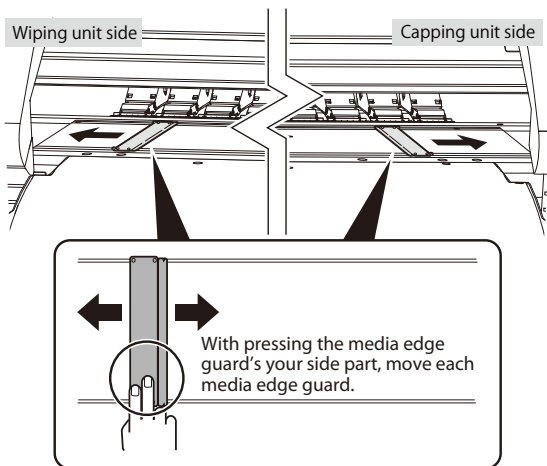

Move the media edge guards to each side.

Move the media edge guards to each side so that they are not under the media.

With pressing the media edge guard's your side part, move each media edge guard.



CAUTION

- Be sure to press the media edge guard on your side when moving the media edge guards. You may get injured if you strongly press the plate's edge while moving the media edge guard.

6

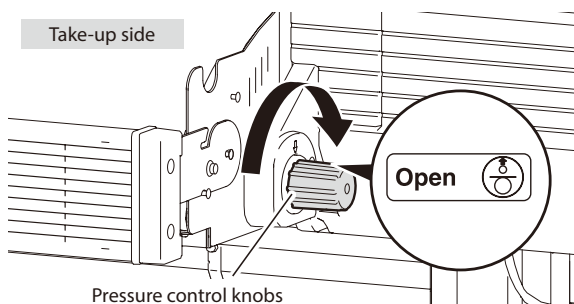

Set the pressure to **Open** by rotating the pressure control knob.

At this step, by pressing and holding the **MENU** button, the Printer enters the offset mode, in which the media is loaded with the slide in the direction to the wiping unit.

After **USE OFFSET MODE** is displayed on the operation panel, select a button from the two below.

- **OK** button, to set the offset mode to ON; or
- **CANCEL** button, to set the offset mode to OFF



Offset mode requires ...

- To load the media in the offset mode, the optional offset loading kit 104 is required.

7

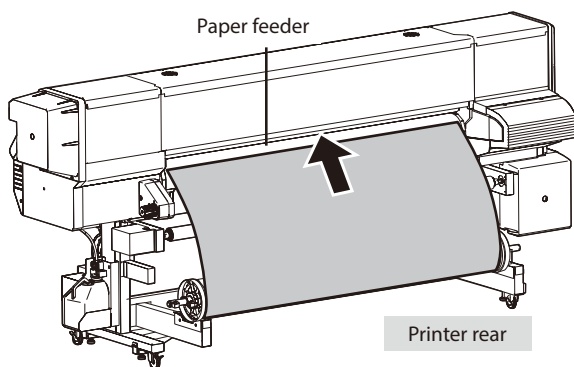

Insert the media end into the paper feeder,

while smoothing out the media by hand to prevent wrinkles.



If the media is curled

- If it is hard to insert the media end into the paper feeder due to a curl of the media, interpose an interleaf and insert the media end under the interleaf as shown in the figure below.

- Upward curl

- Downward curl

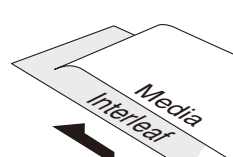
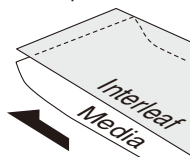

8

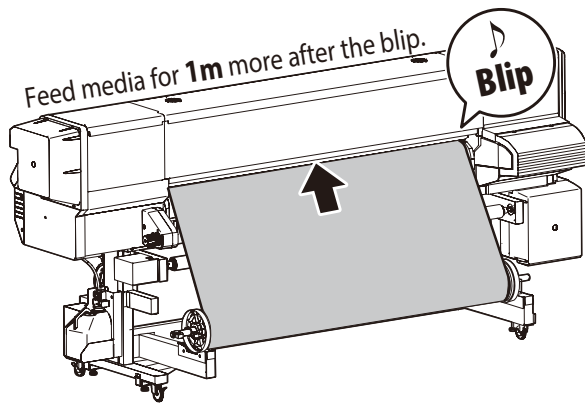

Feed the media for 1m more after the blip.
In this state, smooth out the media toward the both sides on the platen to make the media center tense.



Point to be checked

- If the media is set with a distortion or wrinkles, it may cause a media jam or skew.

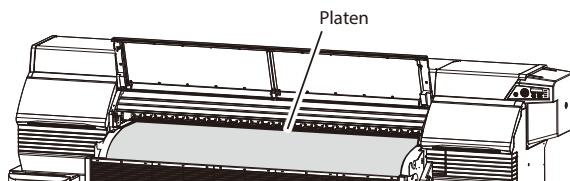

9

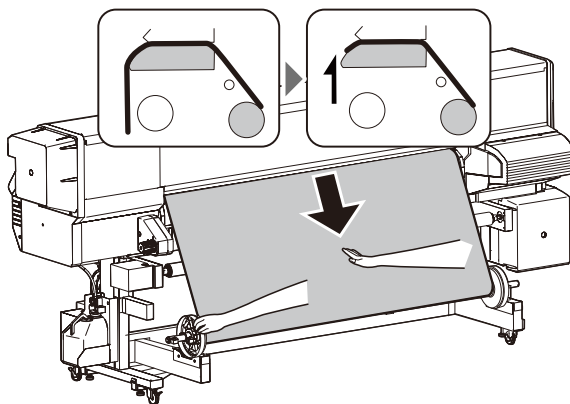

Feed back the media.

Feed back the media while pressing the center of the media gently at the supply side.
Confirm that the front media edge precedes the closed front cover by approx. 30 cm.

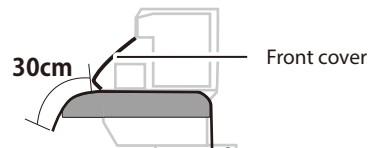

Important!

- This step is important to set the media straight.

10

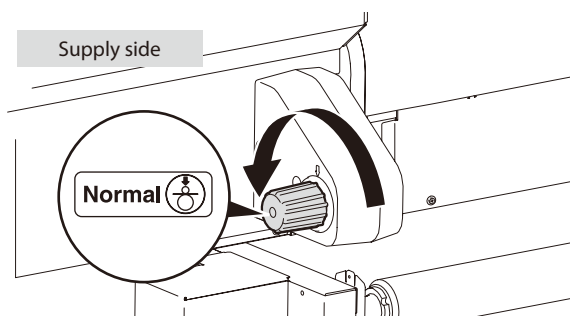

Set the pressure to **Normal** by rotating the pressure control knob counterclockwise.



Point to be checked again

- Check that the media on the platen has no wave or wrinkle.

11

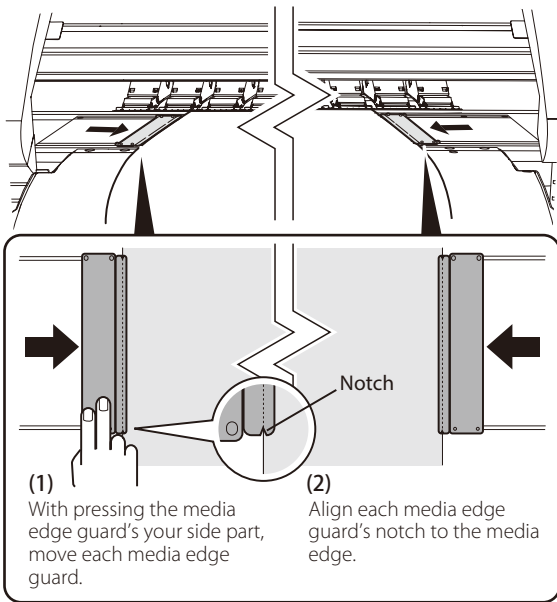

Set the media edge guards.

- (1) With pressing the media edge guard's your side part, move each media edge guard to the media edge.
- (2) Align each media edge guard's notch to the media edge.



Check that the media edge guards are not under the media or thick media is not caught by having been inserted forcibly.

CAUTION

- The print operation without media edge guards may cause a media jam.
- Be sure to press the media edge guard on your side when moving the media edge guards. You may get injured if you strongly press the plate's edge while moving the media edge guard.

12

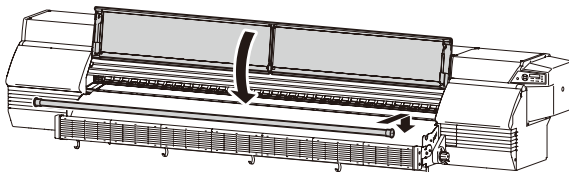

Close the front cover, and set the protection bar.

13

CHECK EDGE GUARD
*OK?



14

SELECT MEDIA
ROLL/SHEET:ROLL



15

SELECT MEDIA
MEDIA:PAPER



SELECT MEDIA
MEDIA:Banner



16

SET REMAINING MEDIA
* * * * m



CHECK
SLACK IN MEDIA

Press the **OK** button.

Press the **OK** button.

Select **Banner** and press the **OK** button.

With the **Up** or **Down** button, select a media preset for the current media type.

Enter the remaining media length and press the **OK** button.

When you do not know the remaining media length, press the **OK** button without entering the length.

17 Adjust the tension bar length on the supply side

To print in TENSION winding mode: Conform the tension bar length with the media width.

The table below lists the tension bar combination and the tension bar's total length. Referring to the list, apply the tension bar length nearest to the media width.

Use the tension bar with no flange 1 indicated on  **page 15**.



To print on banner media ...

- To print on banner media, you are recommended to load the media in TENSION winding mode.

To print without winding: The table below lists the tension bar combination and the tension bar's total length. Referring to the list, apply the tension bar length nearest to the media width.

Tension bar length

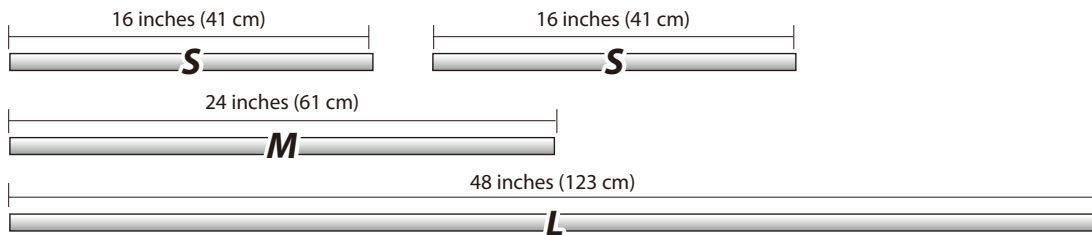

Examples of tension bar combinations

Media width	Tension bar combination	
	TENSION winding mode	Other modes
36, 38 inches	S, S	L(light)
39, 44 inches	M, S	
45, 52 inches	L	
53, 60 inches	M, S, S	
61, 68 inches	L, S	
69, 76 inches	L, M	
77, 82 inches	L, S, S	
83, 94 inches	L, M, S	
95, 104 inches	L, M, S, S	

To print without winding: Use the L (light) tension bar

Use this tension bar when printing without winding, and with vinyl and solvent printing coated media.

Use the tension bar with no flange 2 indicated on  **page 15**.



To print in LOOSE winding mode: Refer to  **page 52**.

When the tension bar is almost same as the media width, or is slightly longer than the media width, set the tension bar with screws to the tension bar.

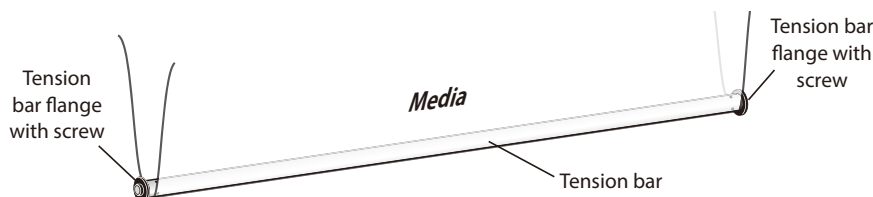

When the tension bar is clearly longer than the media width, set the tension bar flanges and fixing rings to the tension bar.

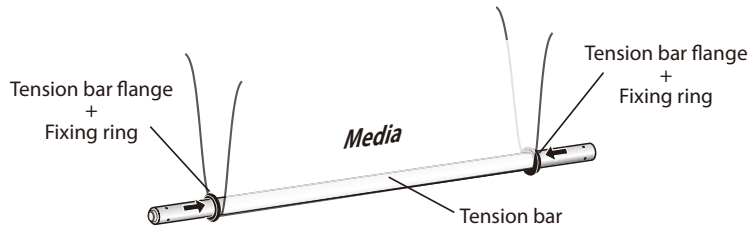

18 Create a slack area in the media.

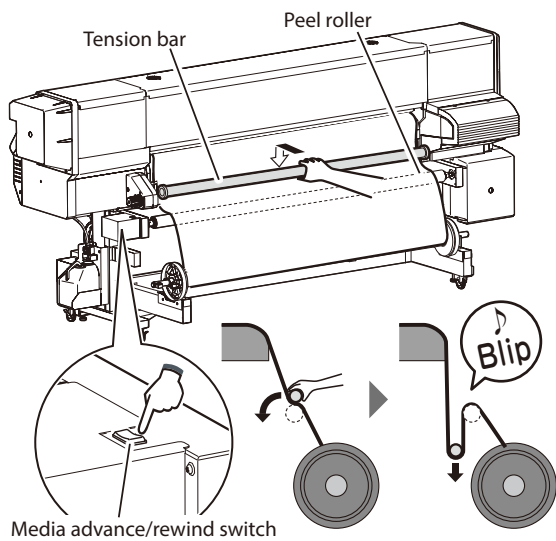

- (1) Press the tension bar to the peel roller's upper part.
- (2) By pressing the media advance/rewind switch, create a slack area in the media. Then, with slightly pressing the tension bar in the direction of the media rear side, install the tension bar in the slack.

Slacken off to a level lower than the supply-side slack sensor.

When the slack reaches the sensor detection area, the operation panel blips.

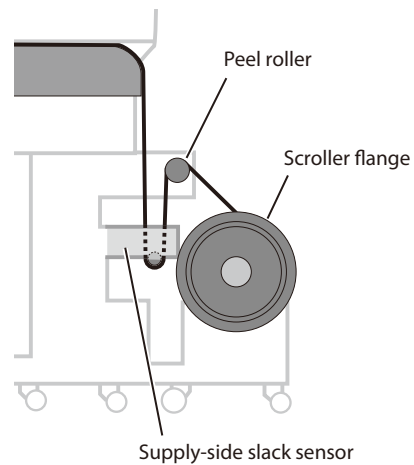

CAUTION

- Do not rotate the peel roller, or the Printer may be damaged.
- Be sure to rotate the peel roller with the media advance/rewind switch.

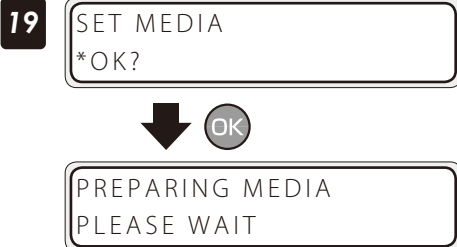

Press the **OK** button.

● **To load media on the take-up reel unit**

This section explains the procedure, taking in TENSION winding mode for instance.

7 Load a paper tube onto the scroller flange and scroller shaft.

Remove the two screws and move the roll spacer to the center of the media. There are three screwing positions.

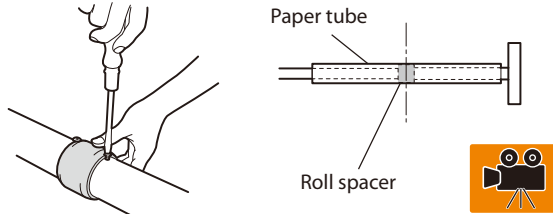

The roll spacer prevents the paper tube from bending at the center due to the media weight. Move it when using media that tends to bend (100-inch media, etc.). Move it also if it comes in the way of the flange spacer used with media short in width.

CAUTION

- Do not grab this roll spacer as it has several protrusions.

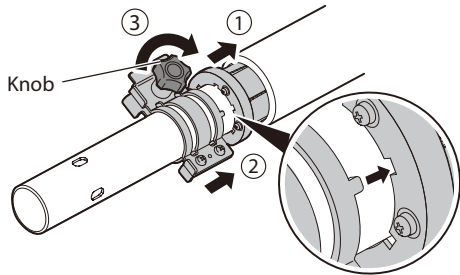
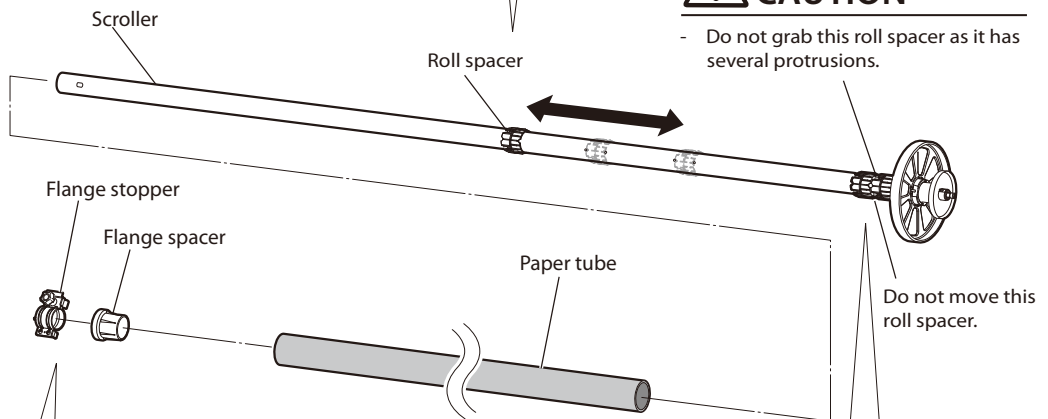

- (1) The flange spacer has teeth. Push it as far as it will go.
- (2) Match the flange stopper with the claw of the flange spacer
- (3) Tighten the knob to secure the flange spacer and the flange stopper.

CAUTION

- Hold the knob to move the flange stopper. Holding another part to move the flange stopper may lead to injuries.

Insert the scroller into the paper tube, determine the distance between the media edge and the flange.

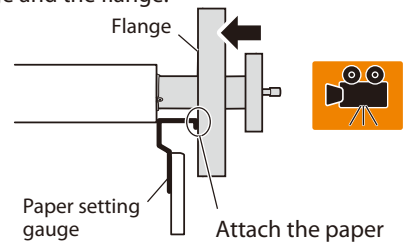

Rotate the handle clockwise as far as it will go, and then secure the scroller at the point.

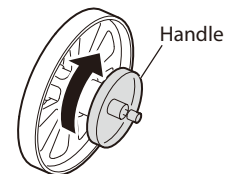

2

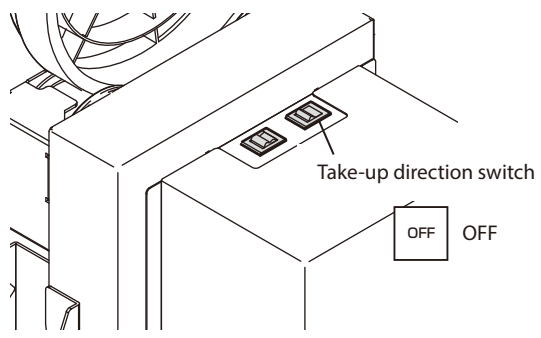

Set the take-up direction switch to OFF.

CAUTION

- If the Printer processing proceeds to the next step with the take-up direction switch set to ON, your hand may be caught as the scroller is not secured.

3

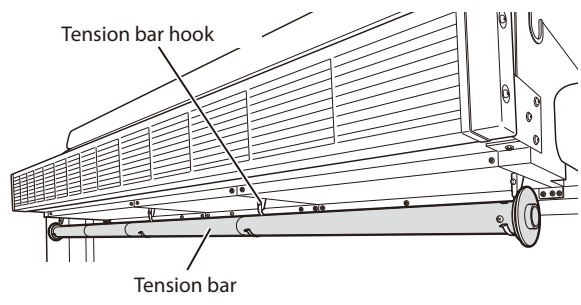

Hook the tension bar to the tension bar hook beforehand.



4

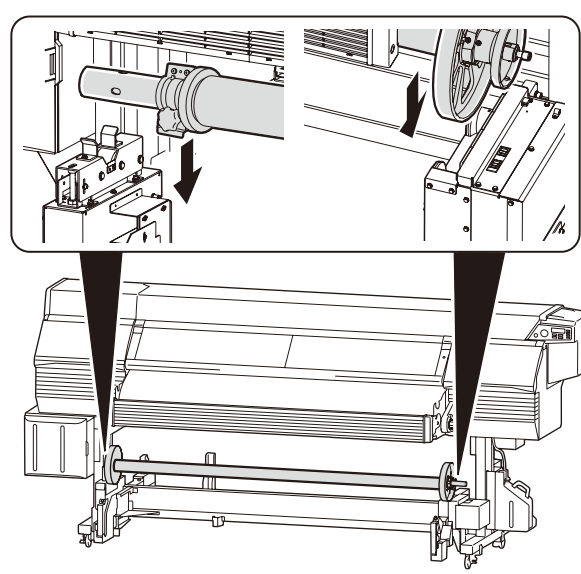

Load the paper tube in the Printer.

CAUTION

- Be careful not to trap your hand or fingers between the Printer and scroller shaft.

5

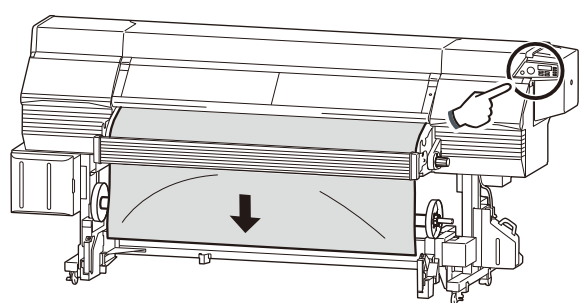

By pressing the **Down** button, feed the media until the front media edge is wound on the paper tube.



FEEDING MEDIA

6

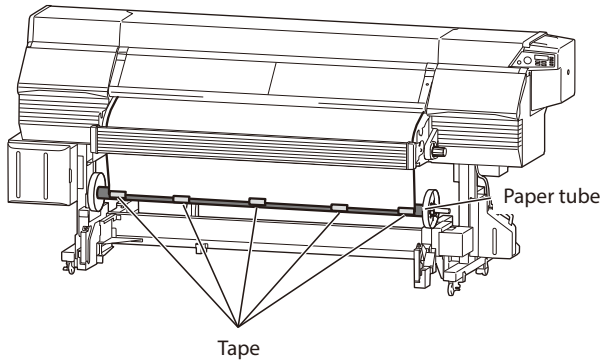

Attach the media passed through the Printer to the paper tube.

- (1) Check the take-up direction, remove the slack of the media, and then make sure that the media position is not deviated on the supply side and the take-up side.
- (2) Attach the media to the paper tube with adhesive tape. Tape it first at the center, and then at the right and left sides, so that the tension is uniform across the media width and that no wrinkles are found on the media. The taped positions are recommended to be three or more in total.

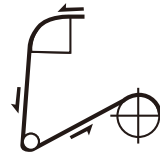

Inner take-up:
Media is taken up with its print surface coming inside.

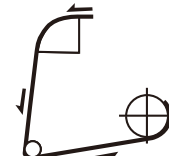

Outer take-up:
Media is taken up with its print surface coming outside.



Points to be noted on winding media

- If the media is not installed straight to the paper tube, a skew of media may occur.
- When the take-up direction is set as Inner take-up, the taken-up media's diameter increases and the media cannot backfeed after printing. Select **FWD ONLY** beforehand in MEDIA BACK MODE of MEDIA REG MENU. (When the media backfeeds in **BACK&FWD** mode, the motor idles and may cause a trouble.)

7

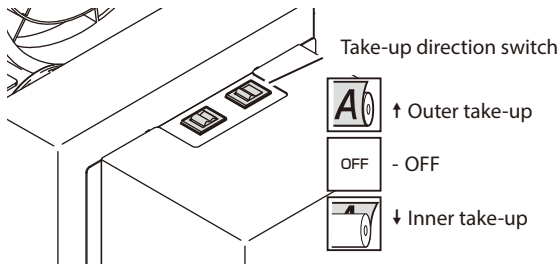

Set the take-up direction switch according to the take-up direction.

8

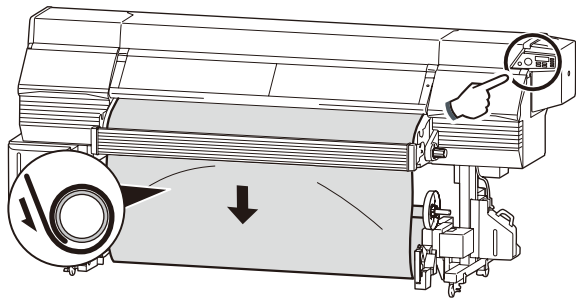

By pressing the **Down** button feed the media, and wind one full turn of the media on the paper tube.



FEEDING MEDIA

CAUTION

- If the tension bar is attached without winding the media by one turn, the tape will peel off.

9

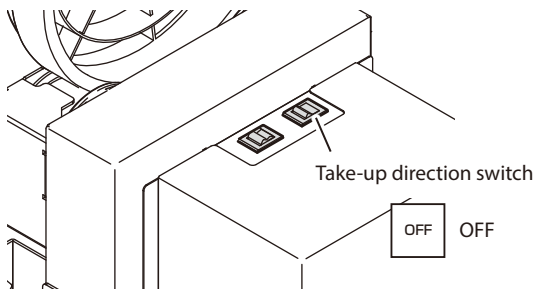

Again set the take-up direction switch to OFF.

10

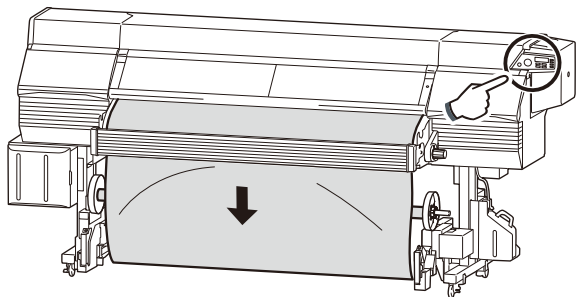

Press the **Down** button to feed enough media to create a slack.



FEEDING MEDIA

Be sure to create a sufficient slack so that you can install the tension bar at the bottom of the tension bar guide.

11

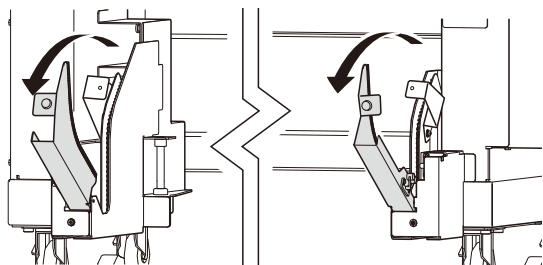

Open the tension bar guide's cover.

12

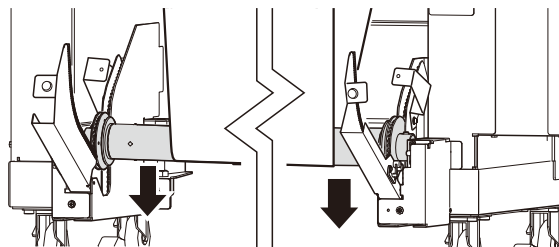

Place the tension bar at the bottom of the tension bar guide.



When the tension bar does not reach the tension bar guide's bottom

- When the tension bar does not reach the tension bar guide's bottom, feed the media with the operation panel's FEED menu. Confirm that tension bar was placed securely at the tension bar guide's bottom.

13

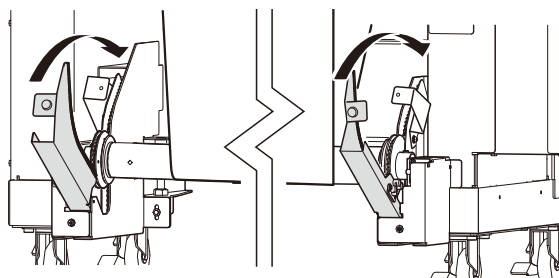

Close the tension bar guide's cover.



When the excessive media slack is created

- If the media slack is secured excessively, the take-up reel unit may keep winding the media for more than the prescribed time, and a take-up timeout error occurs. In such a case, turn off the take-up direction switch, and then press the switch again.

14

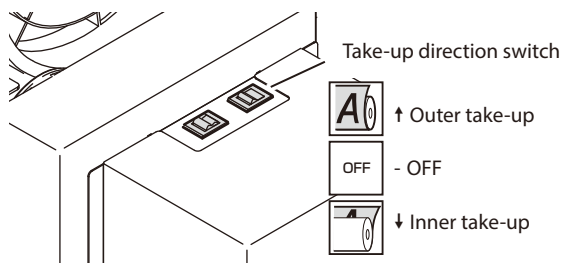

Set the take-up direction switch according to the take-up direction.

15

Input the data in the RIP software.

Procedure to remove media roll from the Printer

Media at take-up side

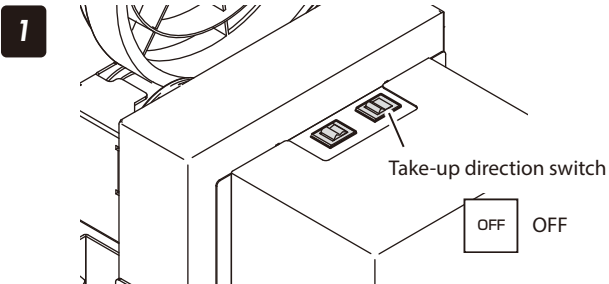

Turn off the take-up direction switch.

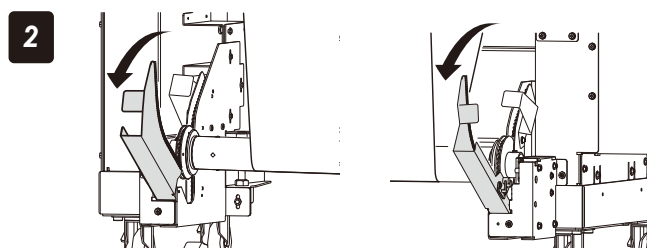

Open the tension bar guide's cover.

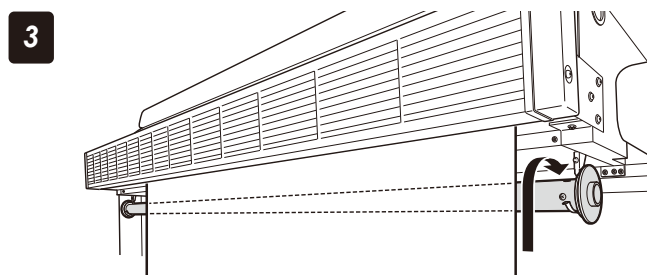

Place the take-up side tension bar at the tension bar hook.

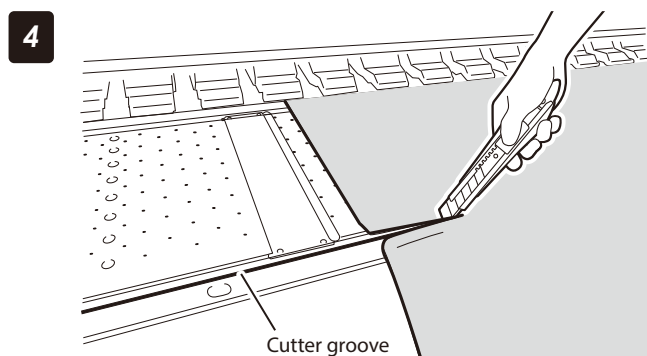

Open the front cover, and then cut the media.

You are recommended to cut the media by setting the cutter blade along the cutter groove.

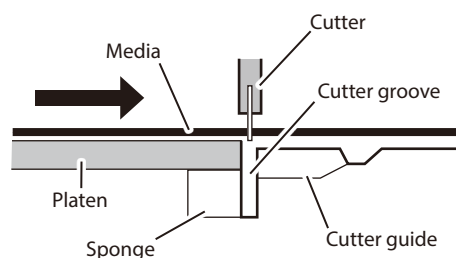

CAUTION

- A net is spread out on the supply side and take-up side paper guides respectively, so that the media will not adhere to the guides. Do not remove these nets.
- When cutting the media, be careful not to damage the paper guide net.
- Pay attention not to drop the printed media to avoid smearing the media.



Set the Printer to offline state by pressing the **ONLINE** button.

6

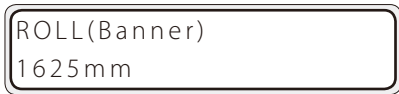

7

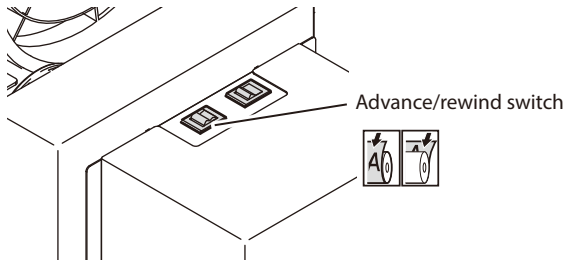

Press the **Left** button.

The media advance/rewind switch is activated by selecting the media and setting the take-up reel unit's take-up direction switch.

Wind the media by pressing the takeup-side take-up reel switch.



If the wound media diameter is so large that the media touches the media drying fan

- Move the media drying fan's position with the procedure below.

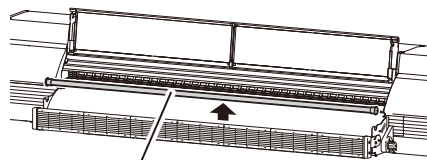

Protection bar

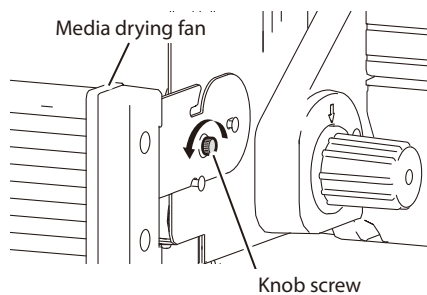

Media drying fan

Knob screw

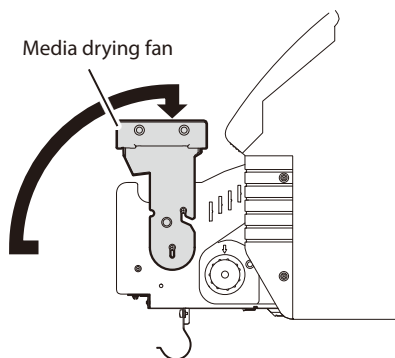

Media drying fan

(1) Remove the protection bar, and then open the front cover.

(2) Loosen the right and left knob screws next to the movable media drying fan.

(3) Pull the media dryer fan toward you, and turn it upward by 90 degrees.



When the media drying fan is turned upward, it slightly goes down and is fixed. To return the fan to its original position, pull it up and turn it downward by 90 degrees toward you, and then push and secure it with the knob screws.

- Turn the media drying fan carefully so that the media drying fan connecting cable does not hung up on the pressure control knob and surrounding sheet metals.

8

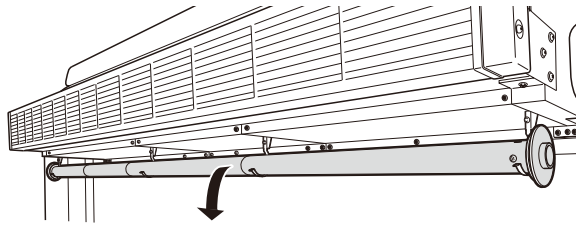

Remove the tension bar from the tension bar hook.

9

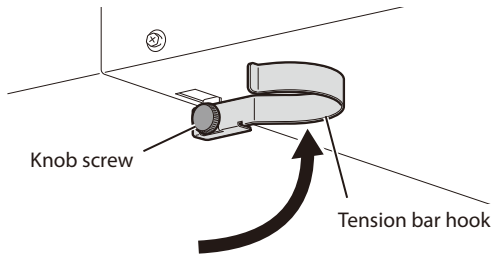

Loosen the knob screw of each tension bar hook and extend it laterally.

10

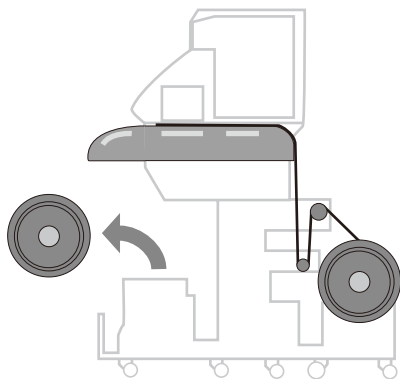

Remove the media from the Printer.

CAUTION

- Media rolls and scrollers are heavy. To prevent injuries, lifting of these components should always be performed by two or more persons and attention must be paid not to let them fall. Additional persons may be required if these components seem to be too heavy. Lifting objects that are too heavy may lead to physical injuries.
- To prevent injuries when loading or replacing the media, use a dolly equipped with a lifter (recommended dolly). If carried by hand, hold the media by the scroller shaft.
- Be careful not to catch your finger or hand between the Printer and the scroller shaft.

On carrying the media alone:

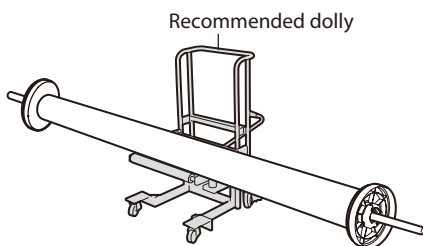

When carried by two or more persons

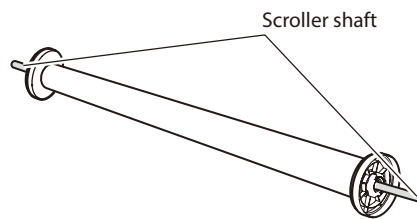

Media at supply side

1 CLOSE COVER



ONLINE

2 ↑INK MEDIA REG↓
←MEDIA M.ADV→



ROLL (Banner)
1625mm

3

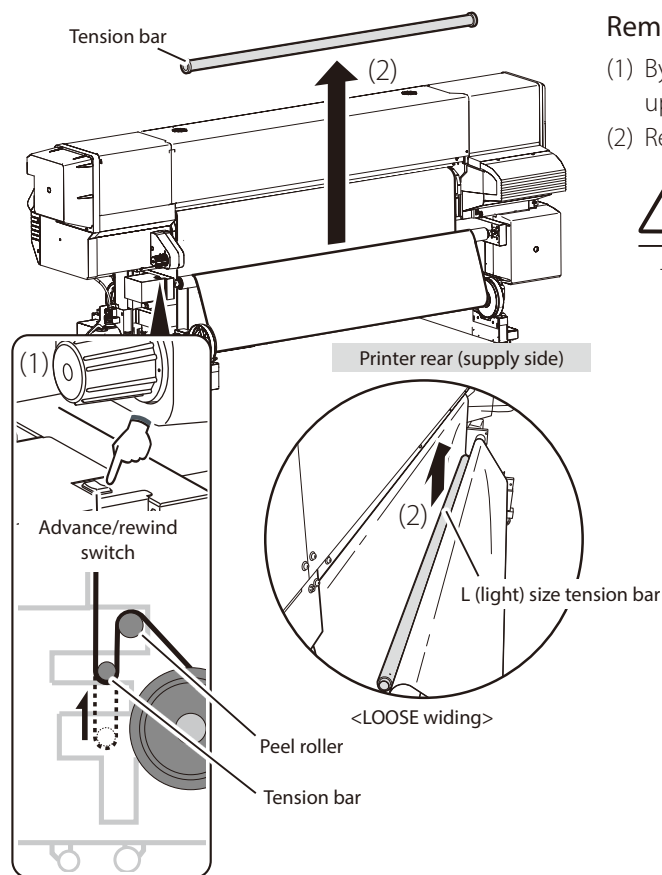

4

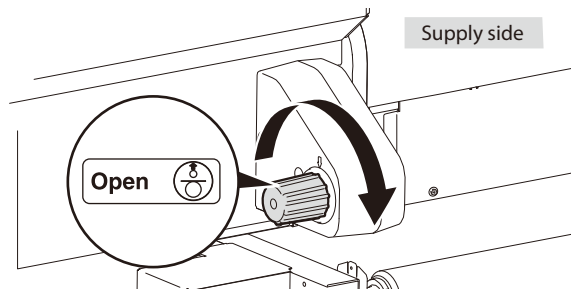

Set the Printer to offline state by pressing the **ONLINE** button.

Press the **Left** button.

The advance/rewind switch is activated by selecting media.

Remove the supply-side tension bar.

- (1) By pressing the media advance/rewind switch, lift up the slack part.
- (2) Remove the supply-side tension bar.

CAUTION

- Do not rotate the peel roller manually with force, or the Printer may be damaged.

5

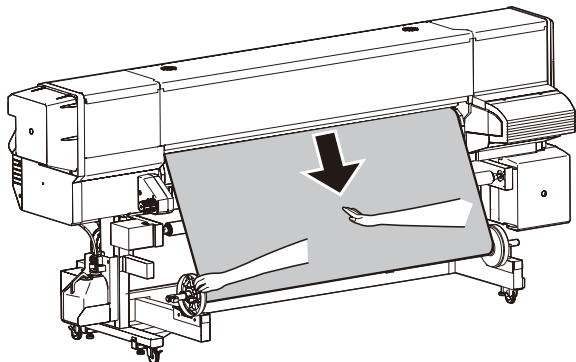

Rotate the scroller flange manually to take up the media.



6

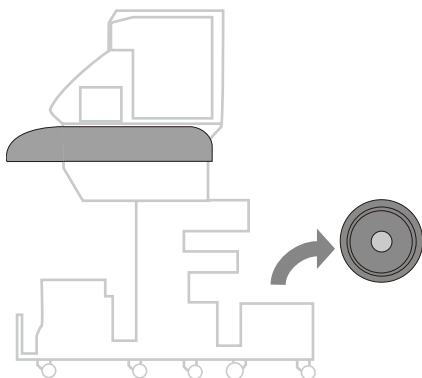

Remove the media roll from the Printer.

CAUTION

- Media rolls and scrollers are heavy. To prevent injuries, lifting of these components should always be performed by two or more persons and attention must be paid not to let them fall. Additional persons may be required if these components seem to be too heavy. Lifting objects that are too heavy may lead to physical injuries.
- To prevent injuries when loading or replacing the media, use a dolly equipped with a lifter (recommended dolly). If carried by hand, hold the media by the scroller shaft.
- Be careful not to catch your finger or hand between the Printer and the scroller shaft.

On carrying the media alone:

Recommended dolly

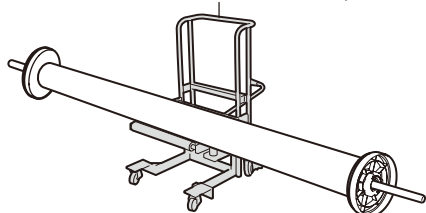

When carried by two or more persons

Scroller shaft

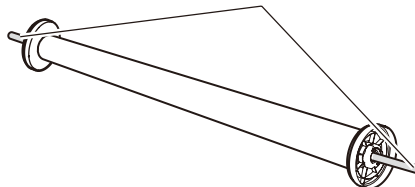

Procedure to remove scroller flange from media roll

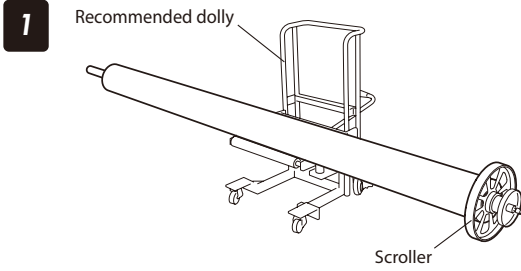

Put the media roll on the table.

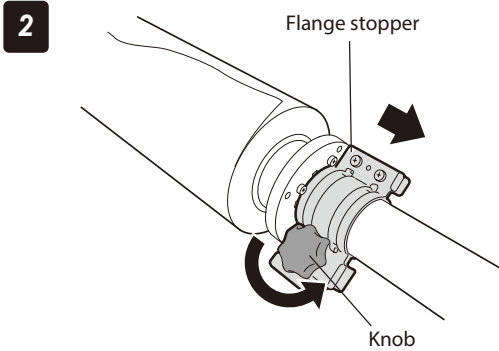

Remove the flange stopper.

CAUTION

- Hold the knob to move the flange stopper. Holding another part to move the flange stopper may lead to injuries.

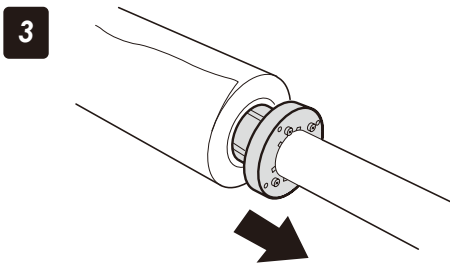

Remove the flange spacer.

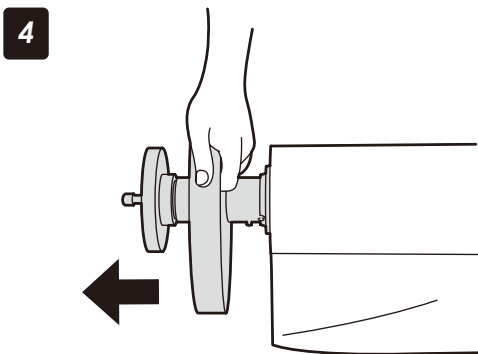

Remove the scroller.

- (1) Rotate the handle counterclockwise.
- (2) When a gap is generated between the handle and the scroller shaft, remove the scroller.

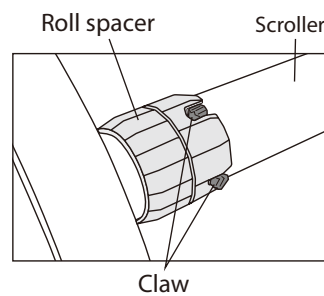

CAUTION

- Do not touch the claw of the scroller.

To print on other media

To print on Vinyl, Mesh banner, Backlit banner (FF), or Solvent printing coated paper

Vinyl

- Winding mode

LOOSE winding mode

- Supply-side tension bar's size

L (light) size

- Printer setting

For glossy vinyl

SELECT MEDIA
MEDIA:Glossy

Media type: Glossy

For matte vinyl

SELECT MEDIA
MEDIA:Matte

Media type: Matte

#MEDIA BACK MODE
>01:BACK&FWD

MEDIA BACK MODE: BACK & FWD

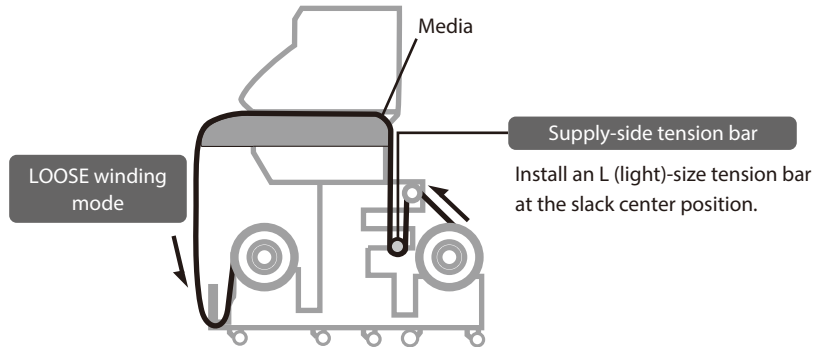

Banner

- Winding mode

TENSION winding mode

- Supply-side tension bar's size

Length conforming with the media width

- Printer setting

SELECT MEDIA
MEDIA:Banner

Media type: Banner

#MEDIA BACK MODE
>01:BACK&FWD

MEDIA BACK MODE: BACK & FWD

#MEDIA ADV MODE
>01:BACK&FWD1

MEDIA ADV MODE: BACK & FWD1

#SUCTION FAN LEVEL
>01:LOW

SUCTION FAN LEVEL: LOW

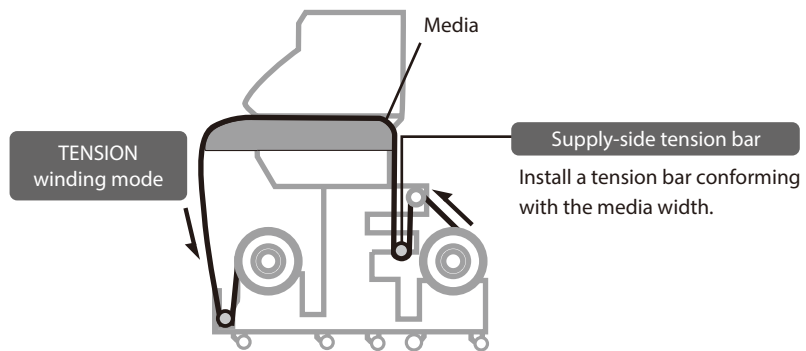

To prevent media jams ...

- You are recommended to set the afterheater temperature to 50°C or less.
- Be sure to install the take-up reel unit.
- Load the media in TENSION winding mode.
- Set the media advance mode to BACK&FWD1
- Set the suction fan to LOW.

Mesh banner (backed)

- Winding mode
TENSION winding mode
- Supply-side tension bar's size
Length conforming with the media width
- Printer setting

SELECT MEDIA
MEDIA:Banner

Media type: Banner

#MEDIA BACK MODE
>01:BACK&FWD

MEDIA BACK MODE: BACK & FWD

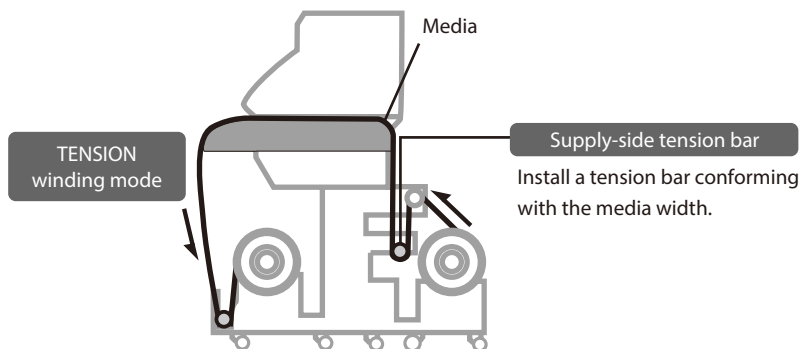

For unbacked mesh banner?

Optional mesh printing kit is required. Load the media referring to "Mesh Printing Kit User's Guide" attached to the kit.

Backlit banner (FF)

- Winding mode
TENSION winding mode
- Supply-side tension bar's size
Length conforming with the media width
- Printer setting

SELECT MEDIA
MEDIA:BLT_B

Media type: BLT_B

#MEDIA BACK MODE
>01:BACK&FWD

MEDIA BACK MODE: BACK & FWD

Aft 50	Prn 40	Pre 45
C) 50	C) 40	C) 45

Afterheater: 50°C / Printheater: 40°C /
Preheater: 45°C

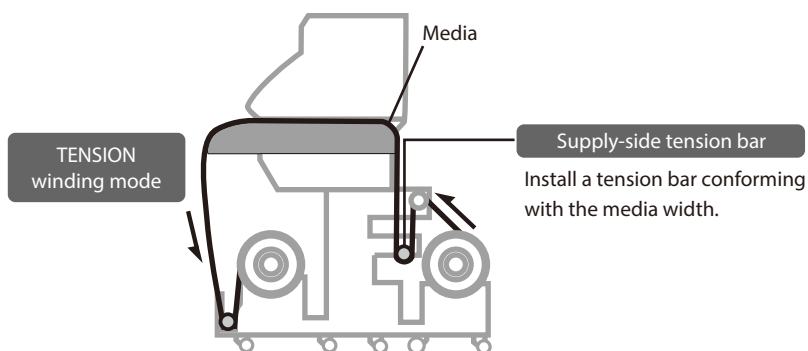

Solvent printing coated paper

- Winding mode
LOOSE winding mode
- Supply-side tension bar's size
L (light) size
- Printer setting

#MEDIA BACK MODE
>01:BACK&FWD

MEDIA BACK MODE: BACK & FWD

#MEDIA ADV MODE
>01:FWD WRINKLEFREE

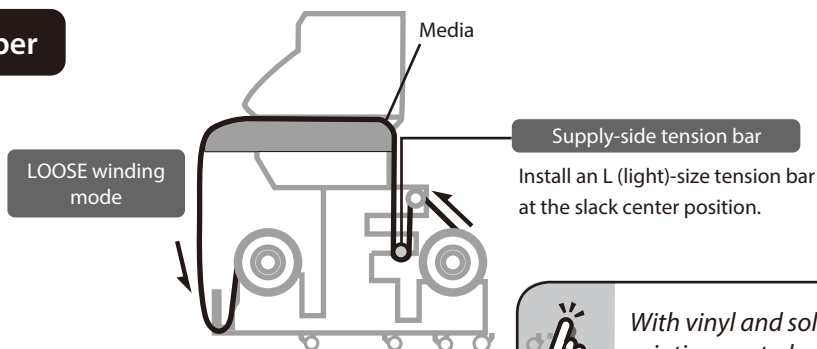

Disassemble the L tension bar and insert the L (light) tension bar into it to adjust the weight of the tension bar.

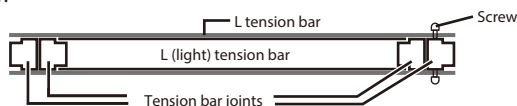

With vinyl and solvent printing coated media

Use the L (light) tension bar regardless of the media width.
- The L (light) tension bar is not equipped with joints and cannot be combined with other tension bars. This bar is to be used with vinyl and solvent printing coated media only.

To take up media in LOOSE winding mode

To prevent media winding deviation, set the paper tube flange to the scroller. Note that the rubber spacers are required depending on the paper tube length as explained below.

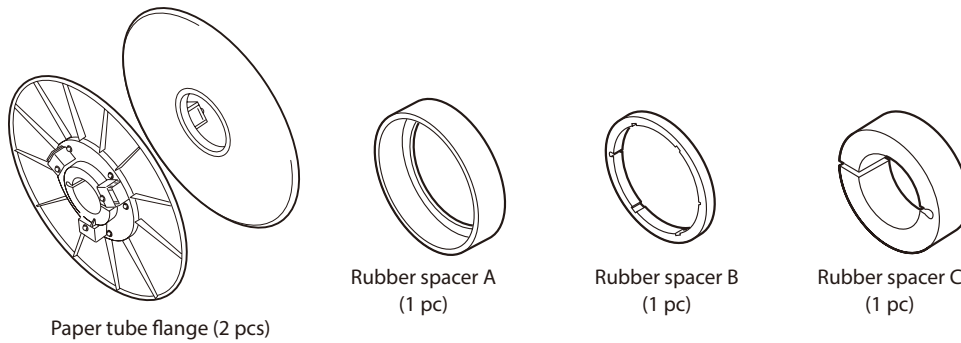

Paper tube, longer than the media width

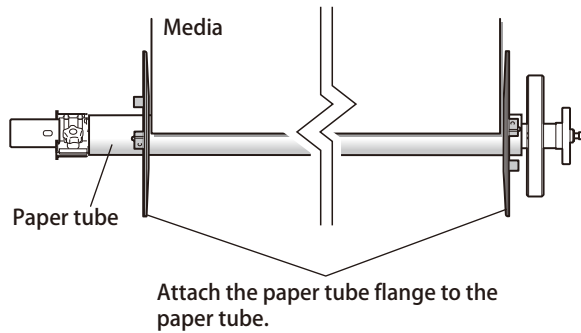
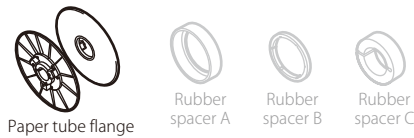

Paper tube, at length conforming with the media width

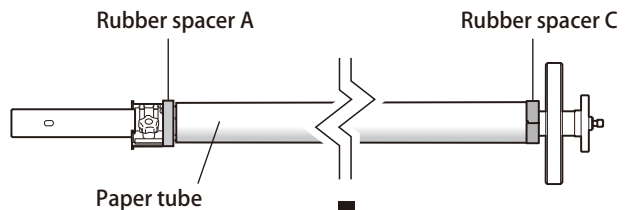
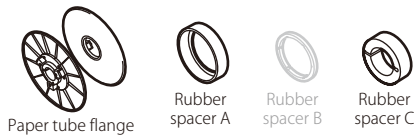

Rubber spacer B's application

When the paper tube's inner diameter is not sufficiently longer than the flange spacer's diameter, the flange spacer cannot be pushed all the way in the paper tube, and the gap may be found between the rubber spacer A and the paper tube edge. In such a case, to clear the gap set the rubber spacer B between the rubber spacer A and the paper tube.

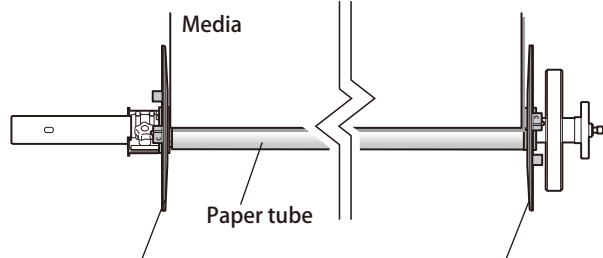
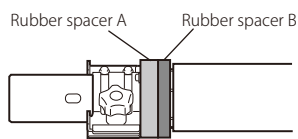

Set the paper tube flange to rubber spacer A.

Set the paper tube flange to rubber spacer C.

7 Install a paper tube to the scroller.

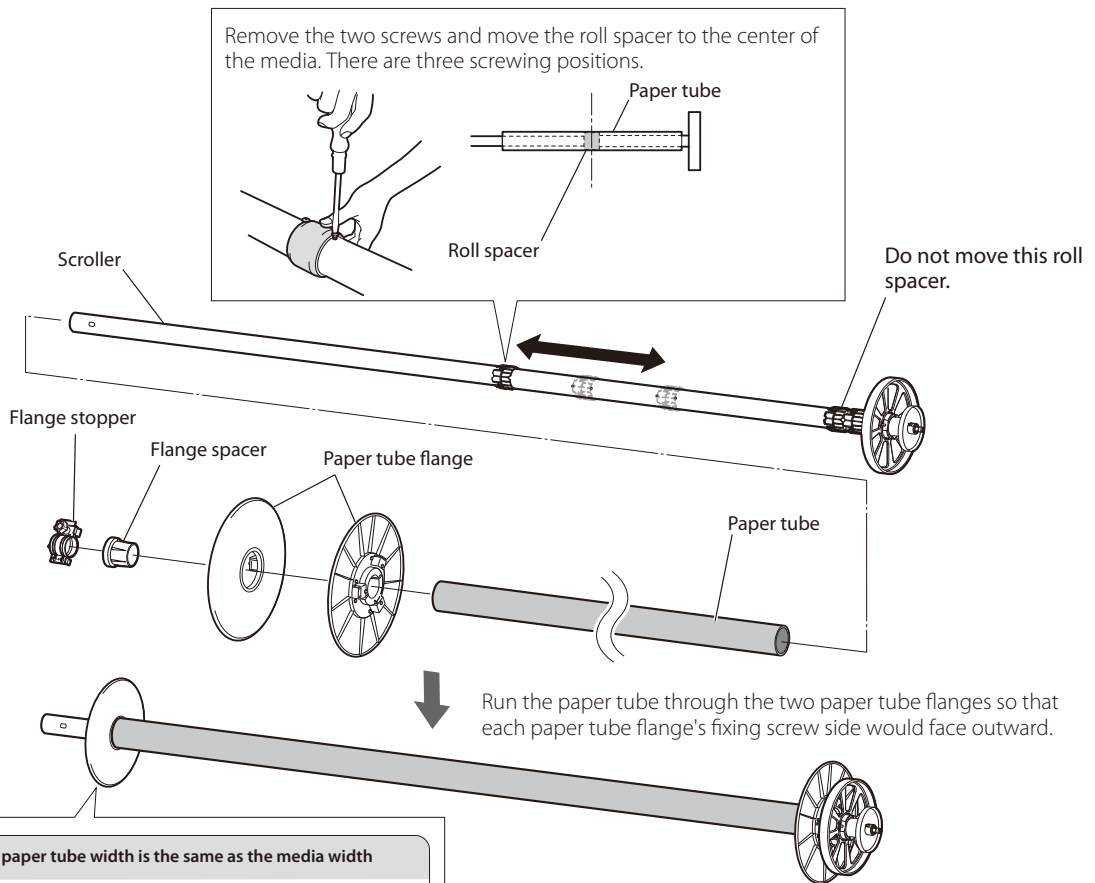

When the paper tube width is the same as the media width

Confirm that the rubber spacer A is facing the correct orientation, and crown the rubber spacer A on the flange spacer.

- (1) The flange spacer has several protrusions. Push the flange spacer until the protrusions are completely inserted in the paper tube.
- (2) Match the flange stopper with the claw of the flange spacer
- (3) Tighten the knob to secure the flange spacer and the flange stopper.

CAUTION

- Hold the knob to move the flange stopper. Holding another part to move the flange stopper may lead to injuries.

Insert the scroller into the paper tube, determine the distance between the media edge and the flange.

Attach the paper setting gauge's flange side to the flange's spoke side.

Rotate the handle clockwise as far as it will go, and then secure the scroller at the point.

When the paper tube width is the same as the media width

Fix the rubber spacer C to the scroller.

2

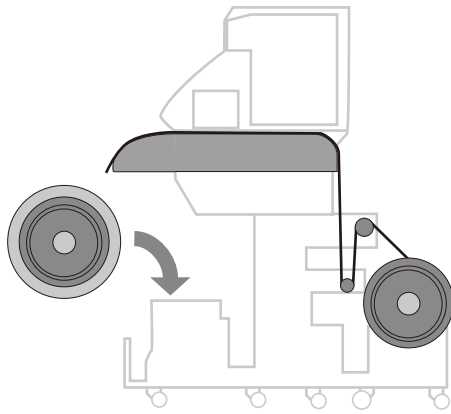

Mount the scroller to the take-up roll.
which will make the operation easier from this step.

3

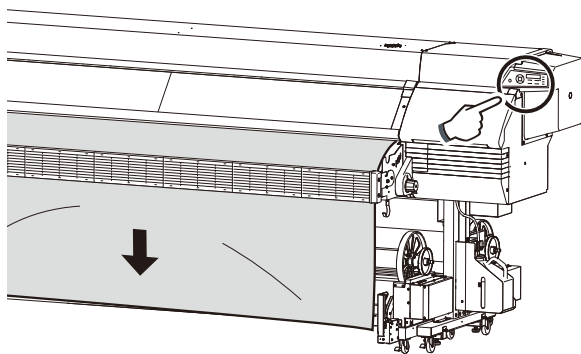

By pressing the **Down** button, feed the media until the front media edge is wound on the paper tube.

FEEDING MEDIA

4

Adjust the paper tube flange position.

By loosening the handle, adjust the paper tube position or the paper tube flange position so that the distance between the media edge and the two paper tube flanges would be **3 to 5mm**.

After the adjustment, fix the paper tube by rotating the handle.

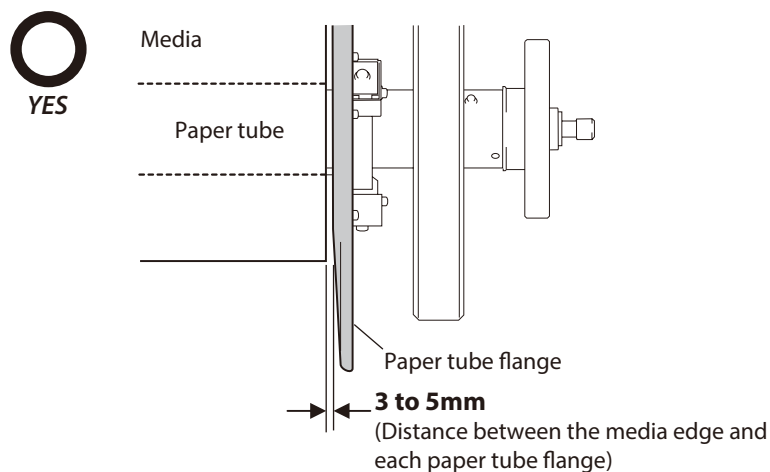
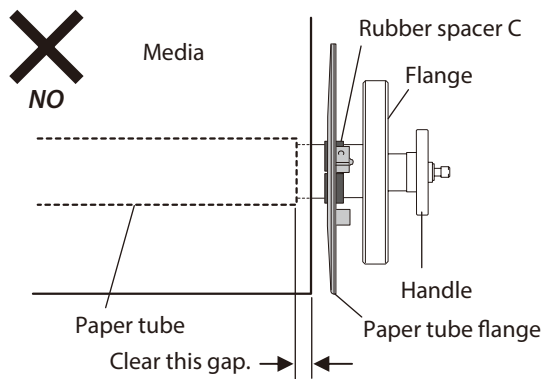
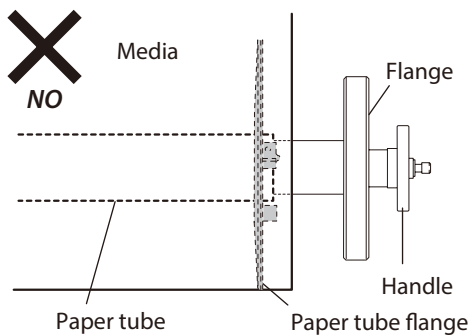

5

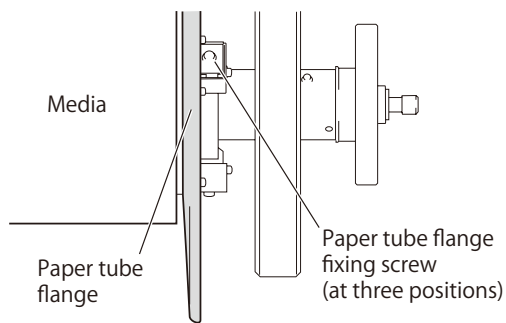

Fix the paper tube flange.

Evenly tighten the three screws on the paper tube flange's external side.

6

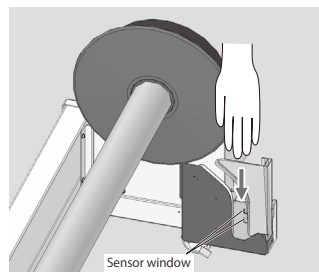

By rotating the take-up roll, confirm that each of the two paper tube flanges does not swing right and left.



To rotate the take-up roll

- (1) Cover the sensor window by sliding your hand downward as shown by the arrow of the left figure. Note that the take-up roll is rotated only with the sensor's downstroke shielding.
- (2) By keeping the sensor window covered, the take-up roll rotates for 4 seconds and stops.
- (3) When the take-up roll needs to be rotated more, repeat the steps (1) and (2).

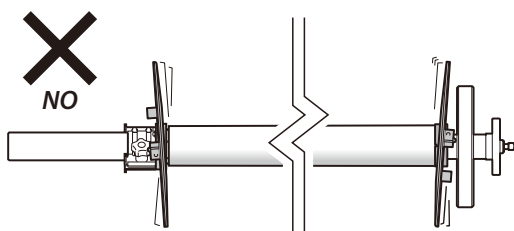

7

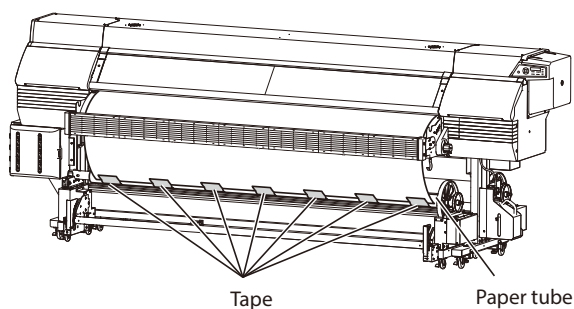

Load media on the paper tube in outer take-up mode.

With adhesive tape, hold the media straight at the center, and then at the rest positions in the direction from the media center to the media edge.

! CAUTION

- Ensure that the media is attached with no slant nor slack which will cause the slanting feed.

8

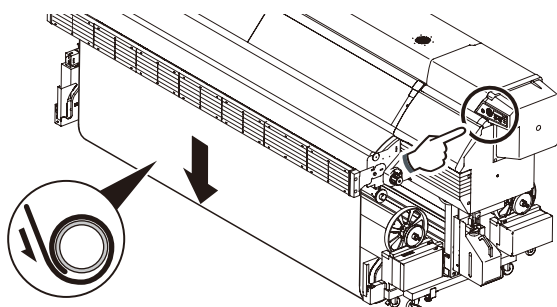

By pressing the **Down** button feed the media, and wind one full turn of the media on the paper tube.

9

Check the paper tube flanges' position, and adjust it if necessary.

To perform double-sided printing



At double-sided printing

- The Printer does not contain the structure to feed media with correctly applying the media advance adjustment value. So the Printer cannot correctly align the first side image with the second side image.

For convenience of explanation on the double-sided printing below, the side printed first is referred to as the **First side** and the side printed next is referred to as the **Second side**. The following procedure is described for the case to print the first side of the media, reinstall the media to the roll feed unit for each media roll that wound the media, and then print the Second side of the media.

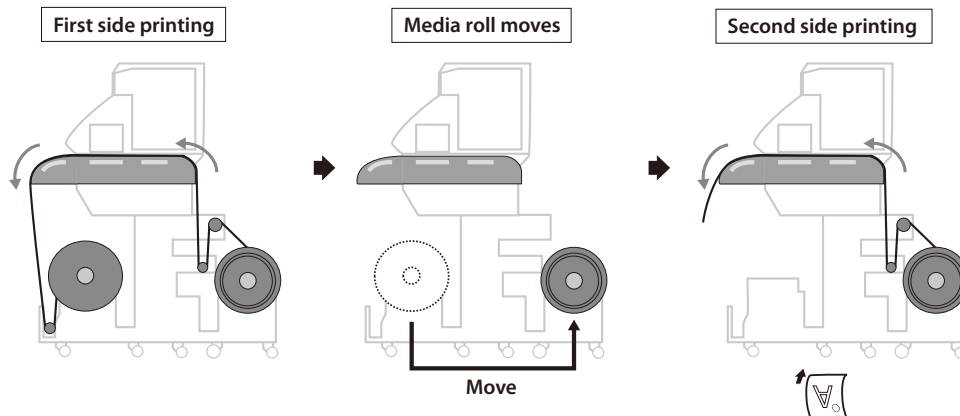

1

SELECT MEDIA
ROLL/SHEET:FACE

Load the media on the Printer.

For the procedure, see **To load media on the Printer** on [page 31](#).

At loading the media, on the operation panel select **FACE** with the **Up** or **Down** button.



Print the rougher side first.

- With a single-sided-printing oriented banner, the roughness grade is different between the front and rear surfaces. To print on such a banner, print on the rougher side first as a first side.

2

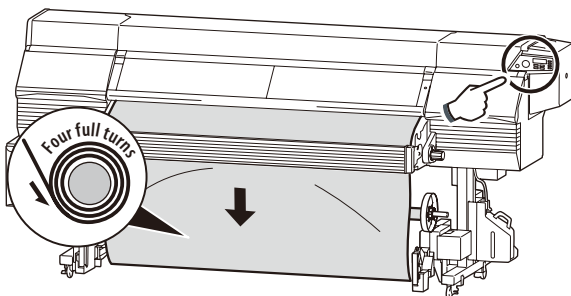

Load the media onto the take-up reel unit.

For the procedure to load the media onto the take-up reel unit, see **To load media on the take-up reel unit** on [page 39](#).



Wind four full turns of the media on the paper tube.

- Since a margin of approximately 2.5 m or more is required for the second side printing, wind about four full turns of media to the take-up reel unit in advance.

3 Start printing on the first side of the media.

4

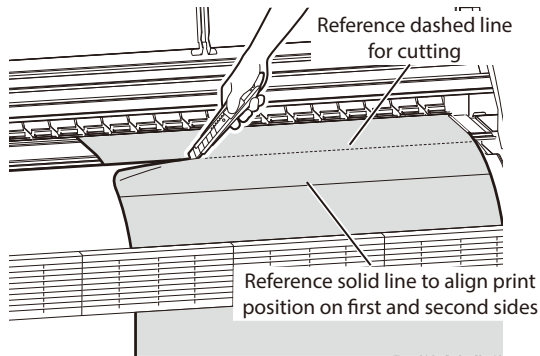

When printing is completed, open the front cover and cut the media.

At the end of the first-side printing, two lines are printed. One line is a reference solid line to match print positions on the first and second sides. The other line is a reference dashed line for cutting.



You are recommended to:

- To cut the media, insert the blade of a box cutter into the gap between the platen and the paper guide.
- To easily install the second side of media, mark the position of the reference solid line at the second side's right and left edges.

CAUTION

- The drying time of printed media varies depending on printed images. Confirm that printed media has dried, and then proceed to the next operation. Generally, dry the printed first side for three hours or more (24 hours for high-density print), and then start second side printing.
- Pay attention not to drop the printed media to avoid smearing the media.

5

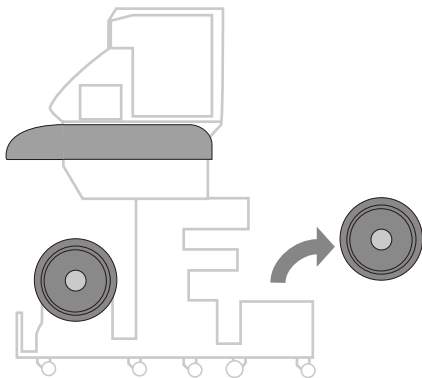

Remove the supply side media roll from the Printer. See [page 47](#).

6

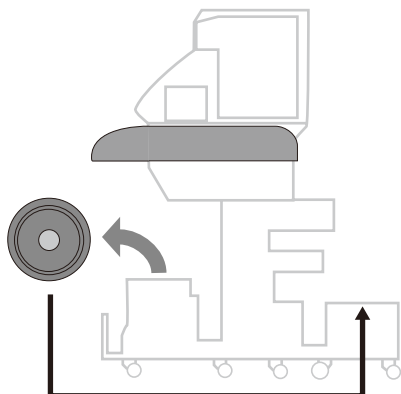

Move the media roll from take-up side to supply side.

Remove the take-up side media roll from the Printer, and move it to the supply side. See [page 44](#).



Before starting the second-side printing...

- Go to the operation panel and change the settings of **#SUCTION FAN LEVEL** in accordance with the used media. If the media tends to stick easily, set **#SUCTION FAN LEVEL** to **LOW**. During second-side printing, the Printer operates in **FWD ONLY** regardless of the **#MEDIA ADV MODE** setting.

Suction fan: **[LOW]**



To avoid the irregular media advance, set the suction fan's vacuum pressure to low.

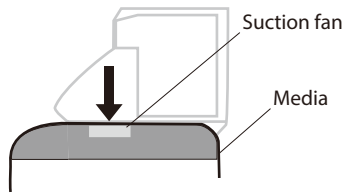

7

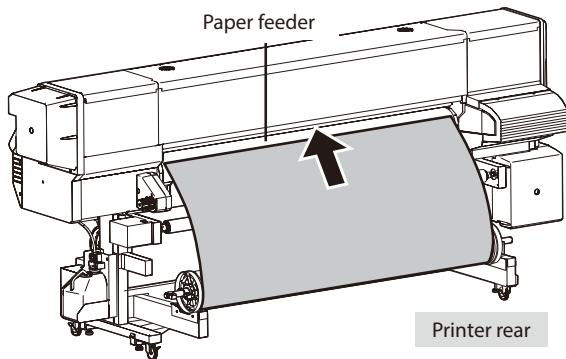

Insert the top edge of the media into the Printer.

With extending the media to eliminate the media wrinkle, insert the media end into the paper feeder.

CAUTION

- The slanted or wrinkled media may cause media jam or skew.



If the media is curled

- If it is hard to insert the media end into the paper feeder due to a curl of the media, interpose an interleaf and insert the media end under the interleaf as shown in the figure below.

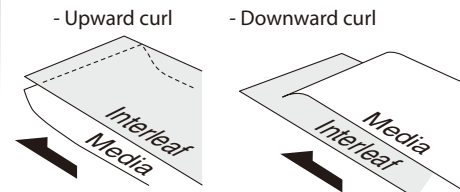

8

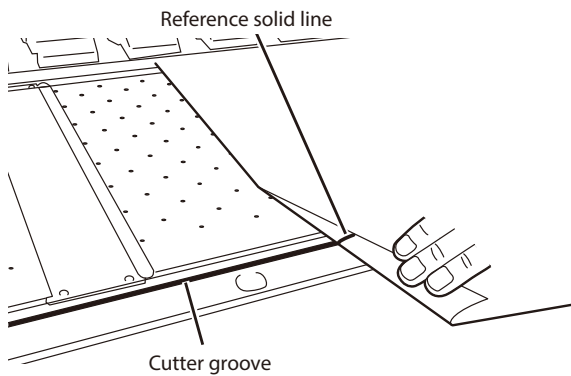

Align the reference solid line with the cutter groove position.

If the line is not aligned at the right and left sides, align it at one side first and hold the position by hand, and then align them at the other side while pulling the media.

9

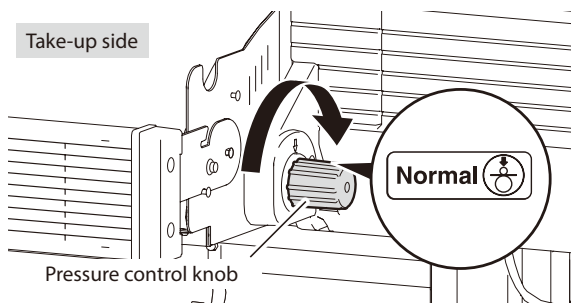

Set the pressure control knob to **Normal**.

- 10** Use the advance/rewind switch to create a slack inside the peel roller. Put the supply-side tension bar on the slack of the media at the supply side. See **page 38**.

Printer rear (supply side)

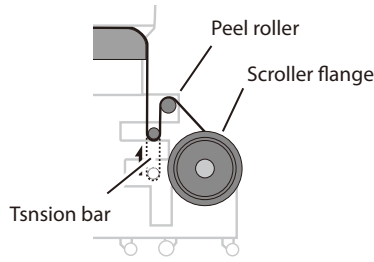
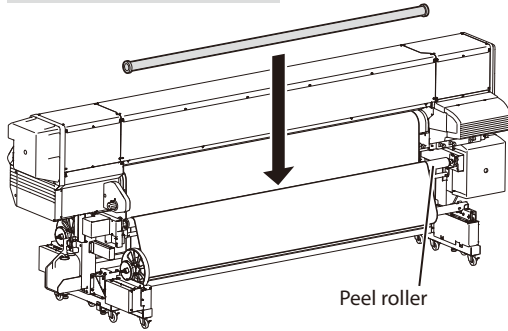

11 CLOSE COVER



CHECK EDGE GUARD
*OK?



12 SELECT MEDIA
ROLL/SHEET:BACK



13 SELECT MEDIA
MEDIA:Banner



14 CHECK
SLACKEN MEDIA



15 PREPARING MEDIA
PLEASE WAIT



- 16** Start printing on the Second side of the media.

Set the media edge guards, and close the front cover.

Select **BACK**, and press the **OK** button.

With the **Up** or **Down** button, select **BACK**.

Select the media type.

With the **Up** or **Down** button, select the media type.

Check the media slack.

- When the media setting is successfully completed, the Printer returns to online or offline state.
- If the media setting is not completed, an error message appears. Retry the procedure from step **7**.

The print head should be cleaned before starting second side printing.



Check the RIP data.

- Note that the data transfer from the RIP differs by 180 degrees between first side and second side.



Daily maintenance

It must be performed every day to ensure the Printer operates without trouble.

Pay particularly attention to the following three items.

- Regularly replenish the wiper cleaning liquid and spittoon absorber liquid.
- Regularly clean the print heads nozzle surfaces using sheet mount cleaning.
- Print heads are highly-precise parts. Do not wipe the nozzle surfaces directly.



























Daily maintenance can be executed from the operation panel but we recommend using CP_Manager supplied with the Printer that includes easy-to-understand explanation movies.

The daily maintenance items are listed below.



Replacement periods of consumables

Consumable type and name		Quantity	Replacement period
IP7-028	Exhaust fan filters	60 pcs	Approx. each month
IP7-027	Dust fan filters	1 roll	Approx. every 3 months
IP7-167	Spittoon case	4 pcs	Approx. every 3 months
	Spittoon unit	1 pc	Approx. each year
IP7-231	Wiper cleaning liquid set A	2 bottles	Approx. every 6 months/ bottle
IP7-233	Wiper blade		
	Rubber blade	8 pieces	Approx. each year
	Sponge blade	8 pieces	

No.	Item	Daily	Weekly	Monthly	Quarterly	Half-yearly	Yearly
A	Media set	 					
B	Capping unit						
C	Waste ink bottle	 					
D	Cleaning						
E	Nozzle print						
F	Wiper blade		 				
G	Wiper cleaning liquid		 				
H	Spittoon absorber liquid		 				
I	Head guard		 				
J	Media edge guard		 				
K	Exhaust fan filters						
L	Carriage						
M	Clean the exterior (front cover)						
N	Sheet mount cleaning			 			
O	Spittoon case						
P	Dust fan filters						
Q	Clean the surface of the sensors for automatic print adjustment						



... Check



... Replenish



... Replace



... Remove



... Set



... Clean



... Panel operation

a Every day

Start Maintenance

A Check that the media does not wrinkle or waves.

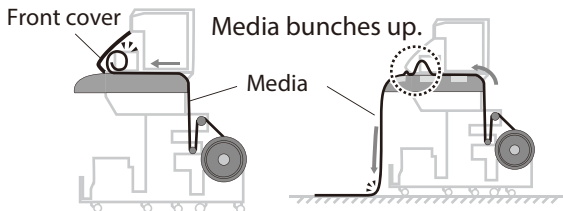

page 66
Check media wrinkles

B Clean the capping unit.

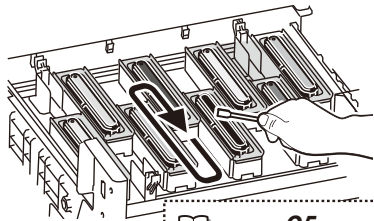
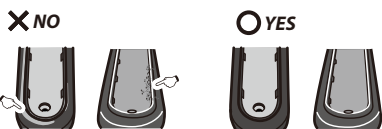

page 95
Clean the capping unit

C Dispose of the waste ink.

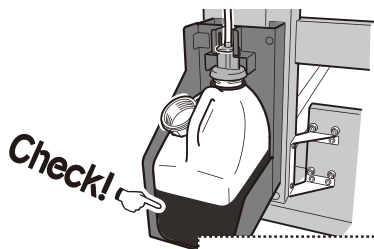

Check!

page 98
Check the waste ink bottle

D Clean the print head.

#PH RECOVERY
>NORMAL

page 99
Performing normal cleaning

After today's operation

Leave the Printer on.

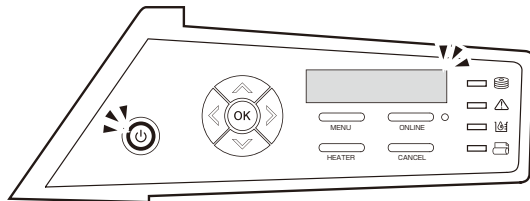

Close the cover.

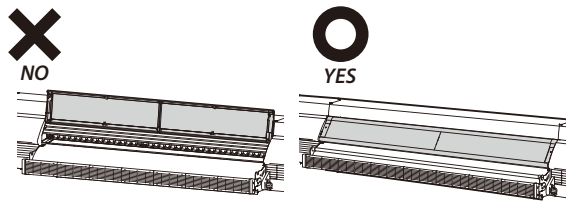

Wind the media.

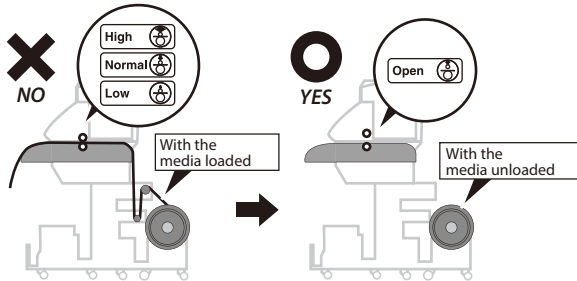

page 104
Remove the media

E Print the NOZZLE PRINT pattern.

#NOZZLE PRINT
#EXECUTE >

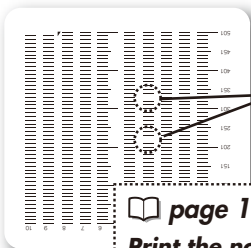

Check!

page 101
Print the nozzle print pattern

No.	Daily	Weekly	Monthly	Quarterly
a	A	S R		
	B	C		
	C	Eye Icon		
	D	P		
	E	P		

No.	Daily	Weekly	Monthly	Quarterly
b	F		Eye Icon	
	G		Eye Icon	
	H		Eye Icon	
	I		Eye Icon	C
	J		Eye Icon	C

b Every week

Start Maintenance

F Is the wiper blade dirty?

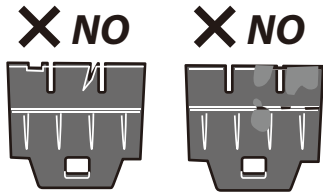

page 87
Check the wiper blade cleanliness

G Is the quantity of wiper cleaning liquid adequate?

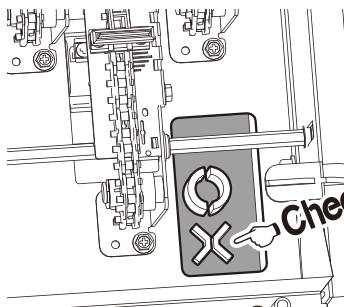

page 85
Replenish the wiper cleaning liquid

X "X" appearing on the tray prompts you to replenish the liquid.

H Check the spittoon absorber liquid.

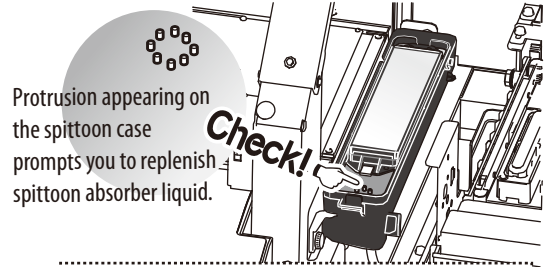

page 81
Replenish spittoon absorber liquid

I Are there particles or dirt on the head guard?

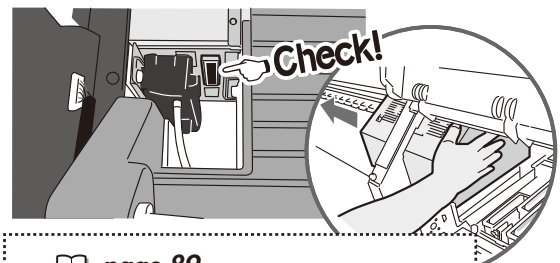

page 89
Clean the head guard

J Check the media edge guards are clean.

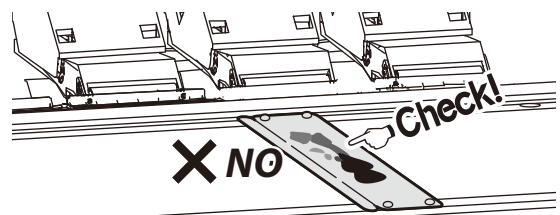

page 83
Cleaning the media edge guard

C Every month

Start Maintenance

K Are the exhaust fan filters dirty?

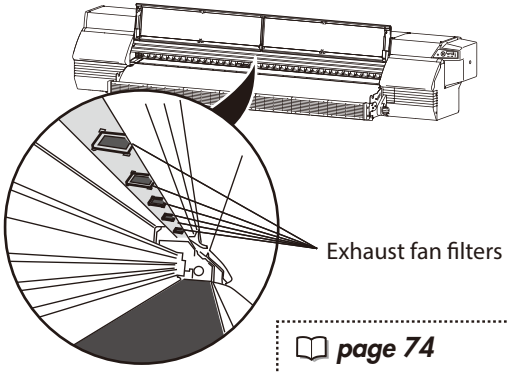

page 74
Replace the exhaust fan filters

L Is the carriage dirty?

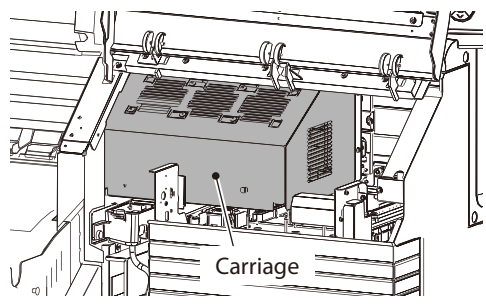

page 77
Clean the carriage

M Are the front cover and other external parts dirty?

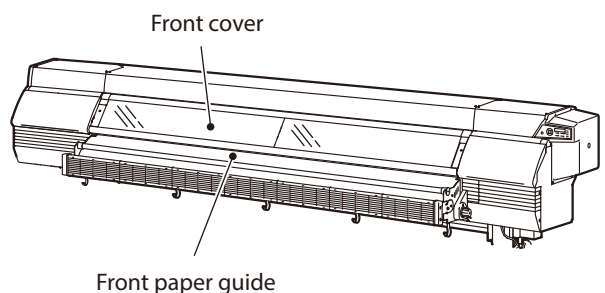

page 79
Clean the front cover

Sheet mount cleaning

N Clean the print heads using sheet mount cleaning.

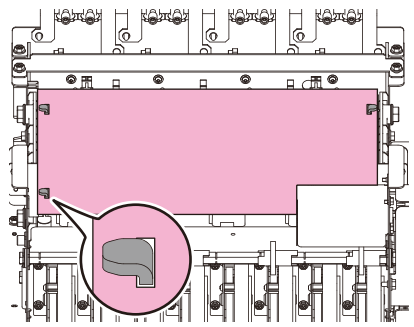

page 105
Clean the print heads

After sheet mount cleaning has finished

N Remove the head cleaning sheet.

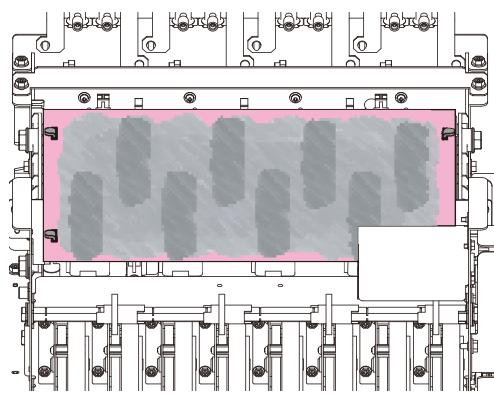

No.	Daily	Weekly	Monthly	Quarterly
C	K			↔
	L		C	
	M		C	
	N		S R	

No.	Daily	Weekly	Monthly	Quarterly
d	O			↔
	P			↔

d Quarterly

O Is the spittoon unit dirty?

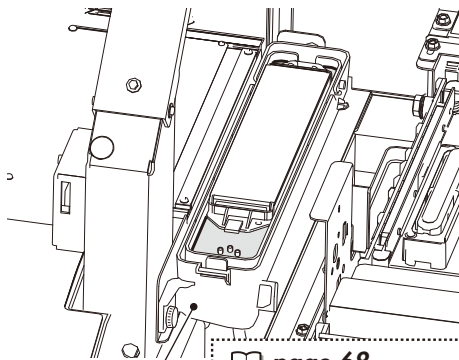

Spittoon unit

page 68
Replace the spittoon unit

P Are the dust filters dirty?

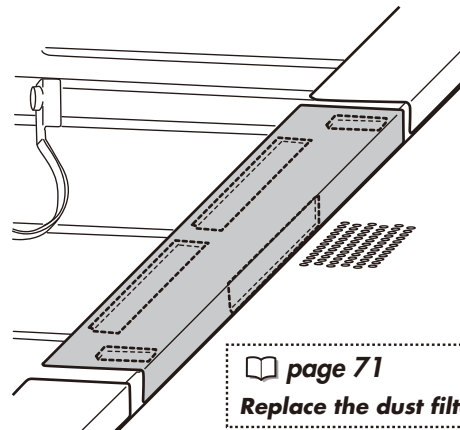

page 71
Replace the dust filters

No.	Daily	Weekly	Monthly	Quarterly	Half-yearly	Yearly
e	G				↔	

e Every 6 months

G Is the wiper cleaning liquid dirty?

Waste liquid bottle
(wiper cleaning liquid)

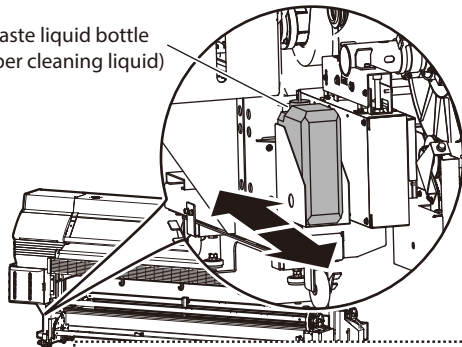

page 135
Replacing the wiper cleaning liquid

No.	Daily	Weekly	Monthly	Quarterly	Half-yearly	Yearly
f	Q					C

f Every year

Q Are the surroundings of the sensors for automatic print adjustment dirty?

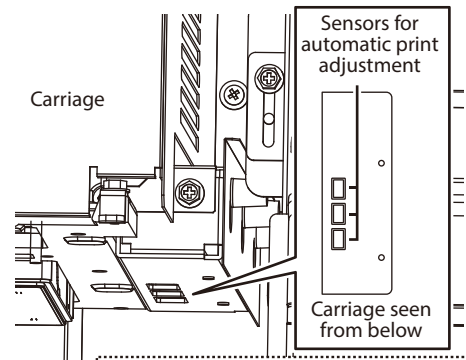

page 92
Clean the surface of the sensors for automatic print adjustment

Start Maintenance

Check media wrinkles

■ Operation location

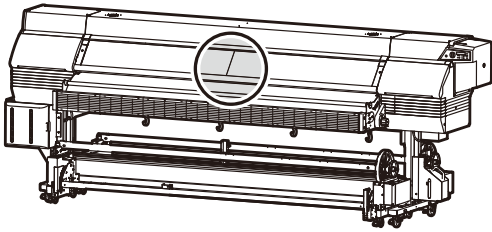

1

CHECK FOR
MEDIA WRINKLE

Check that the media is not wrinkled.

If it is wrinkled, either set the media again or feed it up to an area without wrinkles.

* Printing on wrinkled media may damage the nozzle surfaces.

Perform start maintenance



Press the **Right** button.

Execute **#START MAINTENANCE** to display guidance for the following maintenance items.

Press the **OK** button to execute an item or the **CANCEL** button to go to the next item.

Replace the spittoon case/unit

■ Operation location

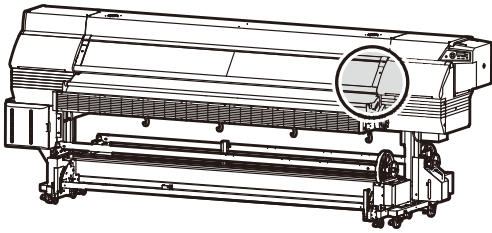

■ Required consumables

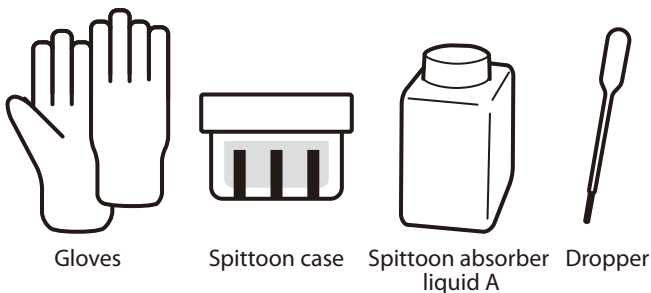

Gloves

Spittoon case

Spittoon absorber liquid A

Dropper

Replace the spittoon case approximately once every three months depending on the amount of dirt on its surface. If a spittoon unit and a tube set are available when replacing the spittoon case, replace them at the same time. (The IP7-167 includes one spittoon unit and one tube for four spittoon cases.) Replace also the spittoon absorber liquid at the same time.



Replace when...

Replace the spittoon case when:

- You find the ink clot accumulated on the spittoon case surface; or
- The net is broken.

When replacing the spittoon case or unit from the operation panel menu, start the procedure from step 1. When replacing while executing **#START MAINTENANCE**, start the procedure in step 4.

You will be prompted to replace the spittoon case or unit during the start maintenance guidance after 3 months or 2.5 km of print length.



Press the **Right** button.



With the **Down** button select **#MAINTENANCE**.



Select **SPITTOON CASE/UNIT** and press the **OK** button.



4 OPEN COVER



5 SPITTOON REPLACED?
YES: OK/NO: CANCEL

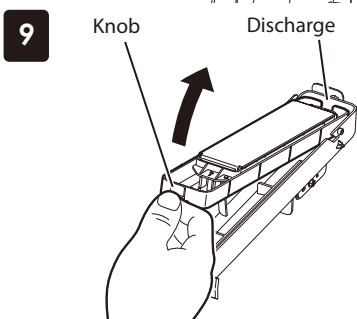
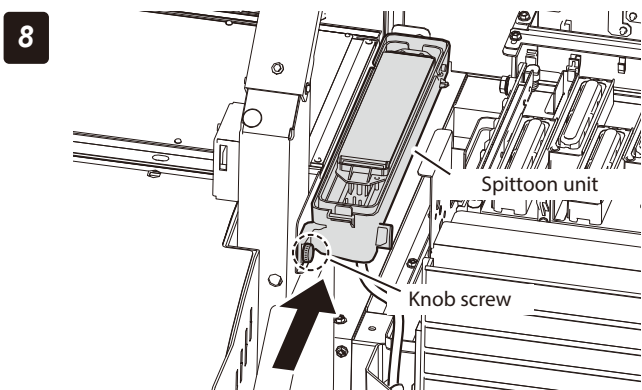
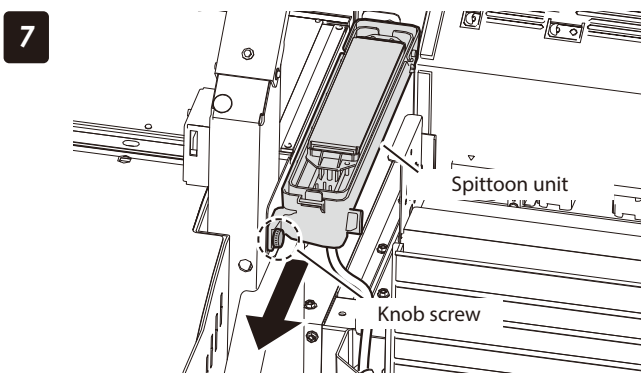
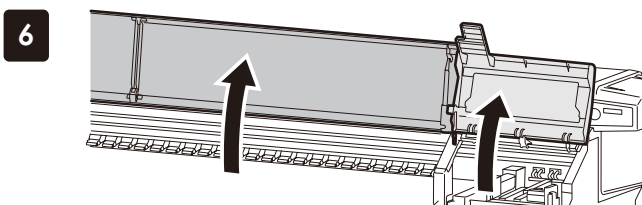

Open the front cover.

After you have finished the replacement procedure described from step 6, press the **OK** button.

Open the front cover and then open the capping cover.

Replace the entire spittoon unit if one is available. If not available, continue the procedure from step 9.

Remove the knob screw of the spittoon unit and remove the spittoon unit.



! CAUTION

- The spittoon unit contains cleaning liquid. Be careful not to spill it.

Install the new spittoon unit with the knob screw.



Press the knob at the near side of the case containing the spittoon absorber liquid to open the lid, raise the front side of the spittoon absorber liquid case to discharge the spittoon absorber liquid to the backside.

The discharged spittoon absorber liquid will go into the waste ink bottle.

When discharge is completed, put the spittoon absorber liquid case back into the original position.



! CAUTION

- Be sure to wear gloves when performing this operation.

10

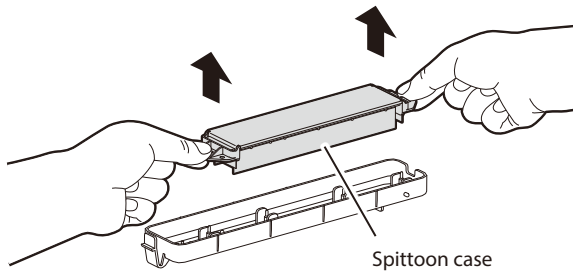

Hold the finger grip at the spittoon case's both side.
Then remove the spittoon case by lifting upward.

11

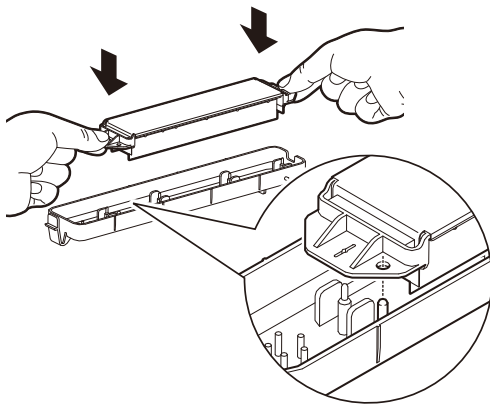

Set a new spittoon case's locating hole to the protrusion, and fix it horizontally by pressing slightly.



12

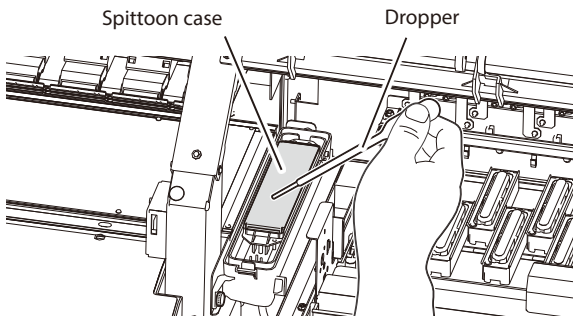

Moisten the spittoon case with the spittoon absorber liquid using a dropper.



13

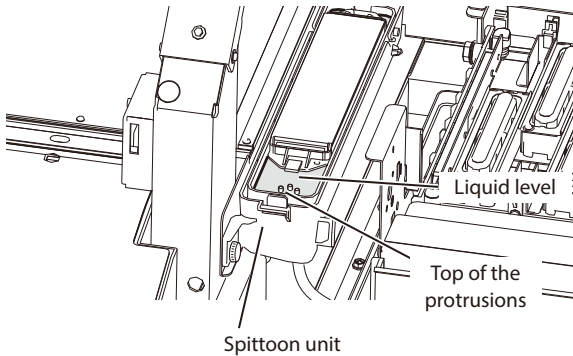

Confirm that the spittoon absorber liquid's top surface is as high as the top of the protrusions.

CAUTION

- In the spittoon case, the spittoon absorber liquid is absorbed by the sponge, which may lower the liquid's top surface.
In such a case apply the liquid additionally.

14

Close the capping cover and then close the front cover.

Replace the dust filters

■ Operation location

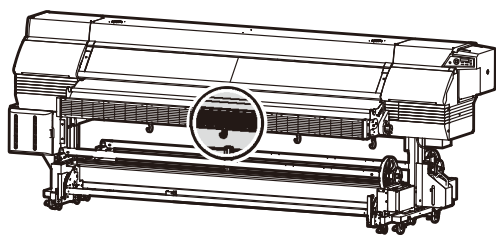

■ Required consumables



Dust filter

■ Check that the suction fan filters are not encrusted with dust.

Suction fan filters, also called dust filters, are attached to the four air exhaust outlets of the suction fan in the Printer's platen.

When the dust filters are covered with dust, this dust may fall onto the media and adhere to it. It is recommended to replace all the dust filters approximately every three months.

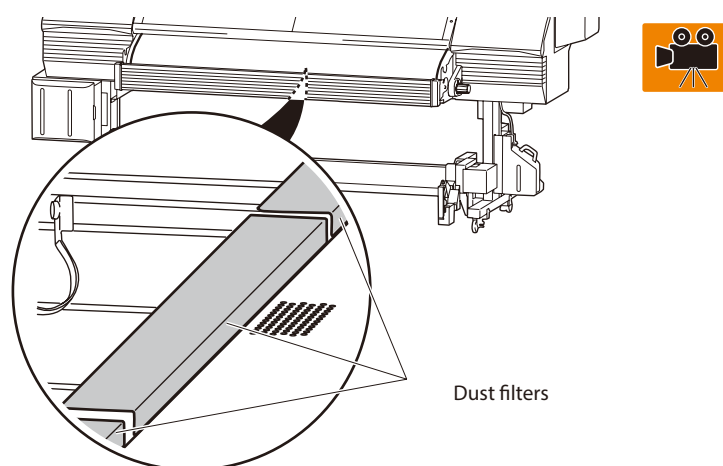

Dust filters

When replacing the dust filters from the operation panel menu, start the procedure from step 1. When replacing while executing **#START MAINTENANCE**, start the procedure in step 6.

You will be prompted to replace the dust filters during the start maintenance guidance after 3 months or 2.5 km of print length.

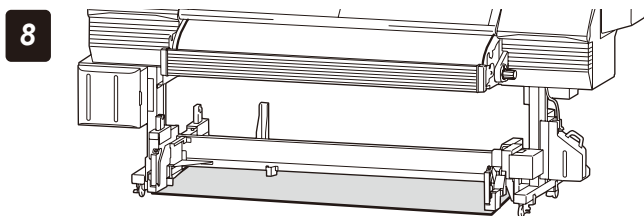
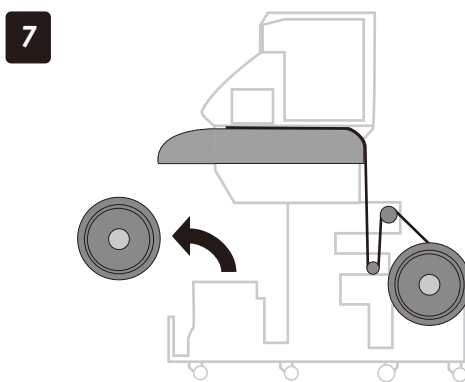

Press the **Left** button.

With the **Down** button scroll to **#MAINTENANCE**.

Press the **OK** button.

Press the **Down** button.

Select **DUST FILTER** and press the **OK** button.

Press the **OK** button.

When the media is installed on the take-up reel unit, remove the media.

By spreading an unnecessary media or cloth on the floor, prevent the floor from being smeared with the ink clot dropped from the old suction fan filters.

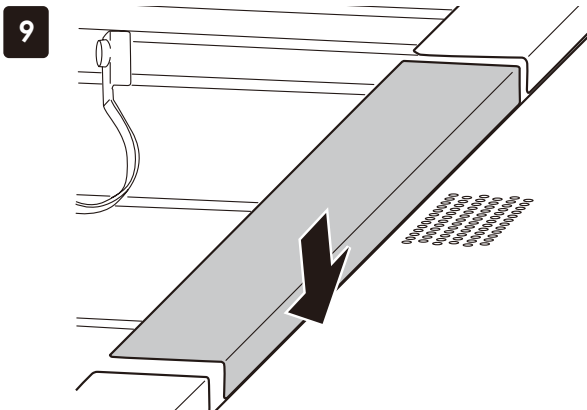

Remove the old suction fan filters from the hook-and-loop fastener.

If the old filter's lint is left on the hook-and-loop fastener, remove it.

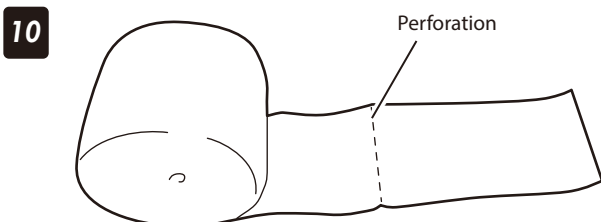

From a new filter roll, along perforation tear off the amount required for the replacement.

Note that one exhaust fan requires four sheets of filter.

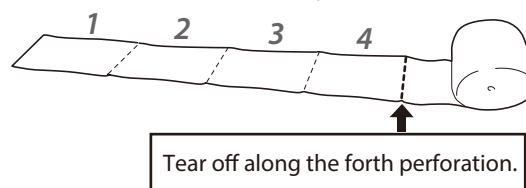

The filter's edge may be deformed, but it does not affect the filter's quality and performance.

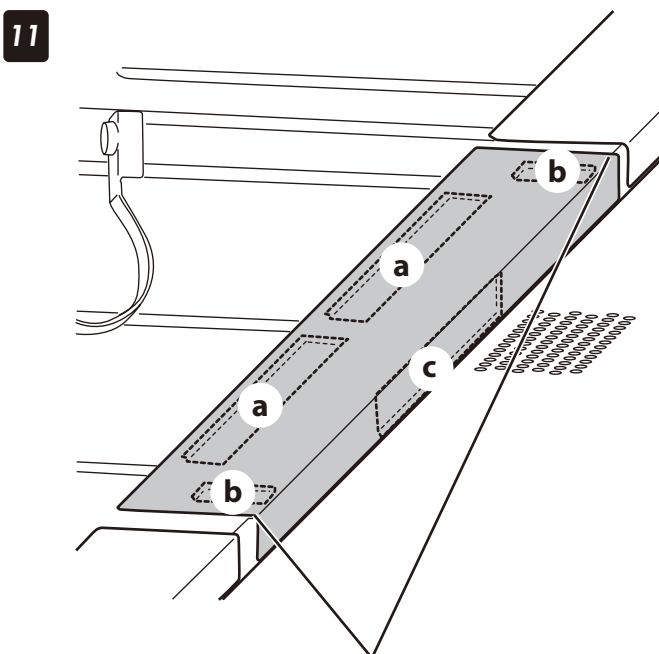
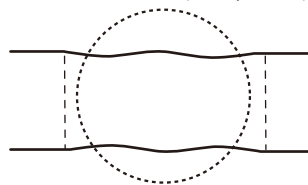

The longer side of the dust filter is slightly longer than the sheet metal.

Install the new dust filters.

- (1) Align the center of the dust filter's longer side with the center of the sheet metal surface with the hook-and-loop fasteners **(a)** and **(b)** attached.
- (2) Attach the dust filter to the hook-and-loop fasteners **(a)** so that the edges of the dust filter and the hook-and-loop fasteners **(a)** are aligned.
- (3) Attach the dust filter to the hook-and-loop fasteners **(b)**.
- (4) Fold the dust filter along the sheet metal's corner, and attach the dust filter to the hook-and-loop fastener **(c)**.



NOTE

- Attach the dust filter as flat as possible, eliminating the filter's wave.

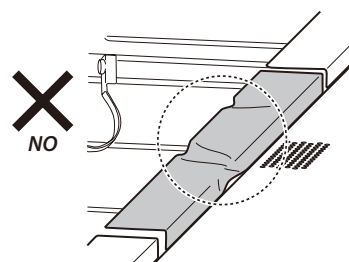

Replace the exhaust fan filters

■ Operation location

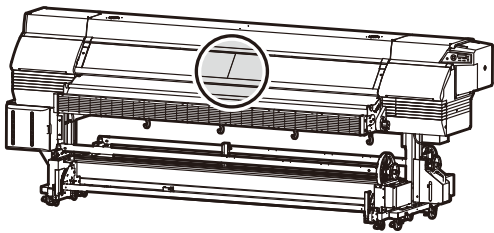

■ Required consumables

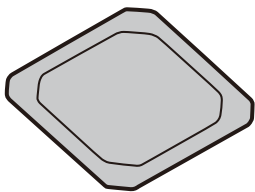

Exhaust fan filter

■ Check that the exhaust fan filters are not encrusted with dust.

Exhaust fan filters are attached to the six fresh air inlets of the fans used to exhaust the ink odor in the Printer. When the exhaust fan filters are covered with dust, this dust may fall onto the media and adversely affect the print quality.

It is recommended to replace all the exhaust fan filters approximately every month or after 800 m of printing.



To check the accumulated print distance ...

See the *Advanced Operation Guide* Check the total print distance on the  **page 25**.

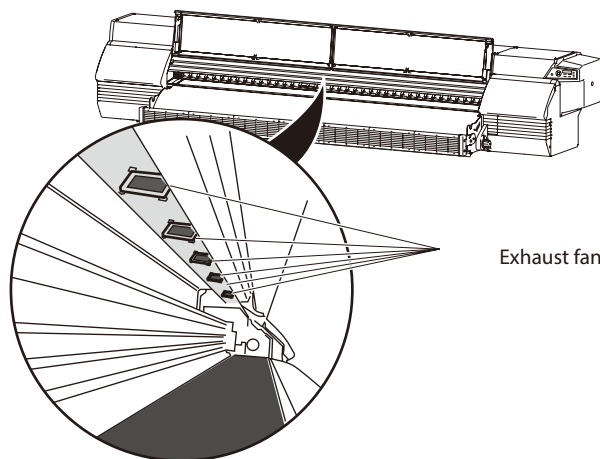

Exhaust fan filters



When replacing the exhaust fan filters from the operation panel menu, start the procedure from step 1. When replacing while executing **#START MAINTENANCE**, start the procedure in step 6.

You will be prompted to replace the exhaust fan filters during the start maintenance guidance after 1 month or 0.8 km of print length.

1 



2 



3 



4 



5 



6 



7 

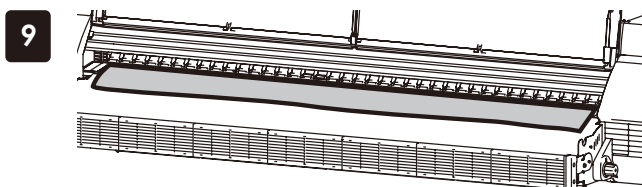
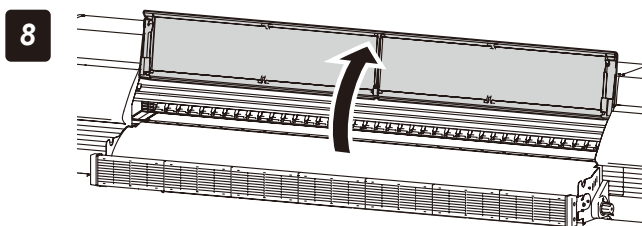

Press the **Right** button.

With the **Down** button scroll to **#MAINTENANCE**.

Press the **OK** button.

Press the **Down** button.

Select **EXHAUST FAN FILTER**, and press the **OK** button.

After you have finished the replacement procedure described from step 8, press the **OK** button.

Open the front cover.

By installing an unnecessary media or cloth on the platen, prevent the Printer from being smeared with the dust accumulated on the exhaust fan filters.

10

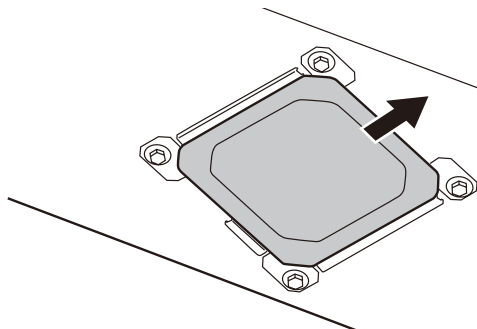

Remove the old exhaust fan filters.



11

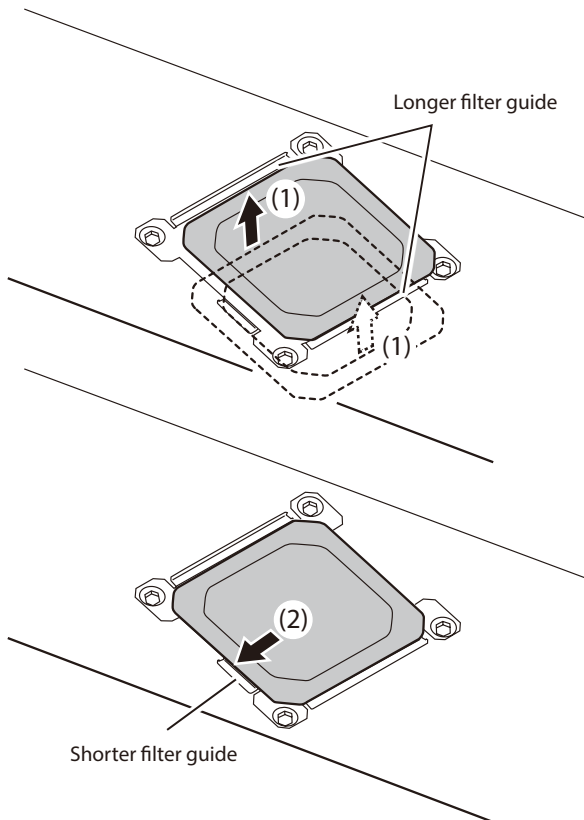

Install the new exhaust fan filters.

- (1) With the brown magnetic side facing upward, set the filter's one side along one of the two longer filter guides. Then set the filter's opposite side to the other longer filter guides.
- (2) Slide the exhaust fan filter until it touches the shorter filter guide.

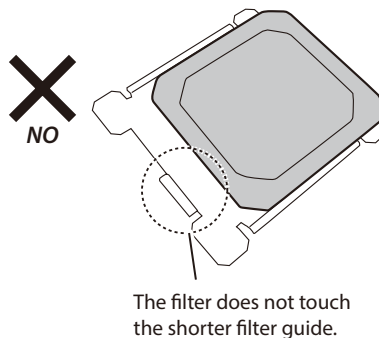

NOTE

- Set the exhaust fan filter so that it is not placed on the filter guide.

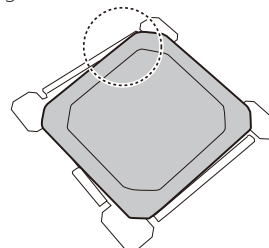

CAUTION

- The improper installation of the exhaust fan filters may affect the Printer's adjustment or cause the Printer's malfunction.

12

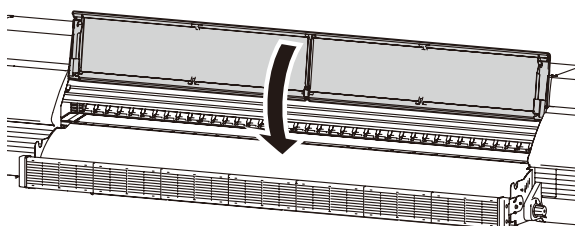

Remove the media or cloth installed at the step 9, and close the front cover.

Carriage cleaning

■ Operation location

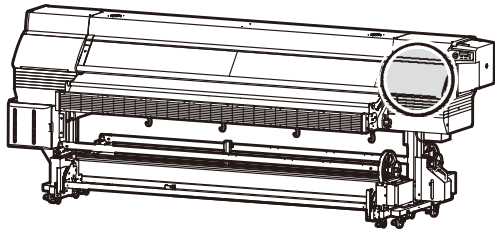

■ Required consumables



Vacuum cleaner

When executing the carriage cleaning from the operation panel menu, start the procedure from step 1. When cleaning the carriage while executing **#START MAINTENANCE**, start the procedure in step 6. You will be prompted to clean the carriage during the start maintenance guidance after 1 month or 0.8 km of print length.



Press the **Right** button.

With the **Down** button scroll to **#MAINTENANCE**.

Press the **OK** button.

Press the **Down** button.

Select **CARRIAGE**, and press the **OK** button.

6 OPEN COVER



7 CARRIAGE CLEANED?
YES: OK/NO: CANCEL

Press the **OK** button.



8 Vacuum the dust off the carriage's fresh air inlet. Monthly cleaning is recommended.

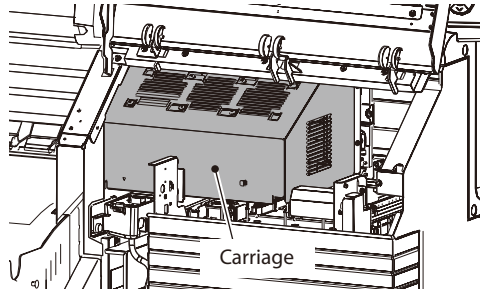

Clean the exterior (front cover)

■ Operation location

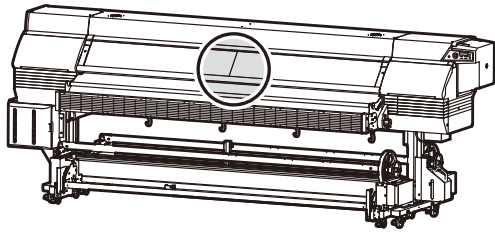

■ Required consumables

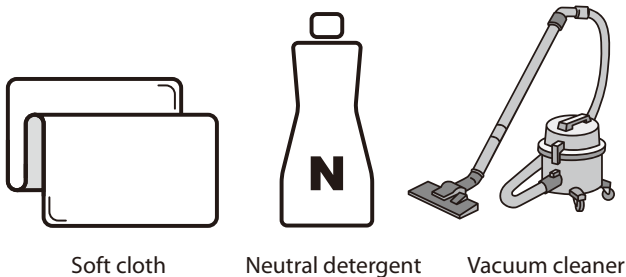

Soft cloth

Neutral detergent

Vacuum cleaner

If the Printer exterior is smeared, moisten a soft cloth with water or water-diluted neutral detergent, wring it, and clean the exterior with the wrung cloth.

CAUTION

- Do not blow off dust and paper dust as they may degrade print quality.
- Never use volatile solvent such as thinner and benzene. The coating may come off or discolor.

When executing cleaning of the exterior from the operation panel menu, start the procedure from step 1. When cleaning the exterior while executing **#START MAINTENANCE**, start the procedure in step 6.

You will be prompted to clean the exterior during the start maintenance guidance after 1 month or 0.8 km of print length.



Press the **Right** button.



With the **Down** button scroll to **#MAINTENANCE**.



Press the **OK** button.



4 # MAINTENANCE
> SPITTOON CASE/UNIT?



5 # MAINTENANCE
> EXTERIOR?



6 EXTERIOR CLEANED?
YES: OK/NO: CANCEL



7 If the Printer is smeared with dust and paper dust, remove them using a vacuum cleaner. If the contamination is heavy, wipe it out with a soft cloth moistened with neutral detergent.

Press the **Down** button.

Select **EXTERIOR**, and press the **OK** button.

After you have finished the replacement procedure described from step 7, press the **OK** button.

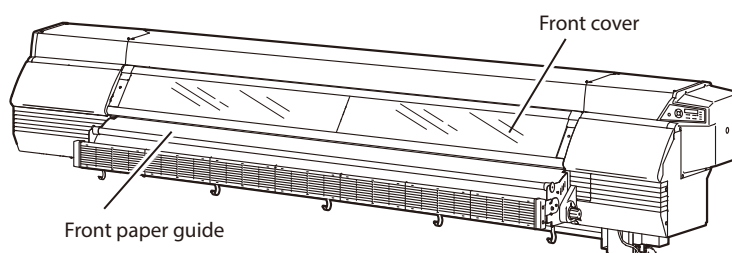

Replenish spittoon absorber liquid

■ Operation location

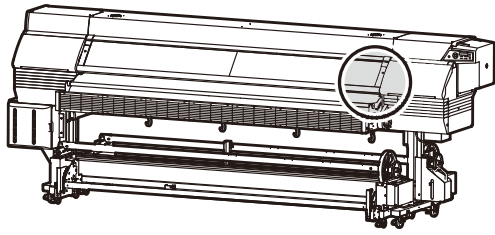

■ Required consumables

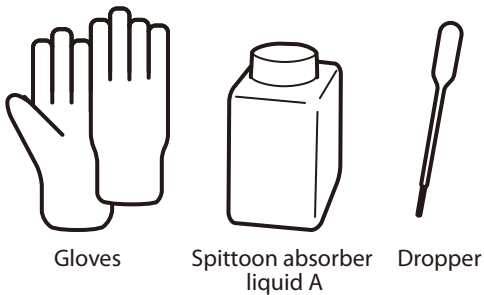

Gloves

Spittoon absorber liquid A

Dropper

When replenishing the spittoon absorber liquid from the operation panel menu, start the procedure from step 1. When replenishing the spittoon absorber liquid while executing **#START MAINTENANCE**, start the procedure in step 6.



Press the **Right** button.



With the **Down** button scroll to **#MAINTENANCE**.



Press the **OK** button.



Press the **Down** button.



Select **SPITTOON LIQUID**, and press the **OK** button.

6

OPEN COVER



7

SPITT. LIQUID CHKED?
YES: OK/NO: CANCEL



8

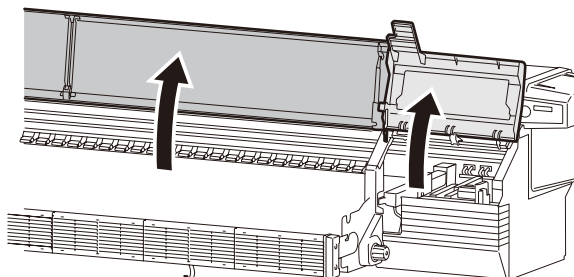

After you have finished the replacement procedure described from step 8, press the **OK** button.

Open the front cover, and then open the capping cover.

9

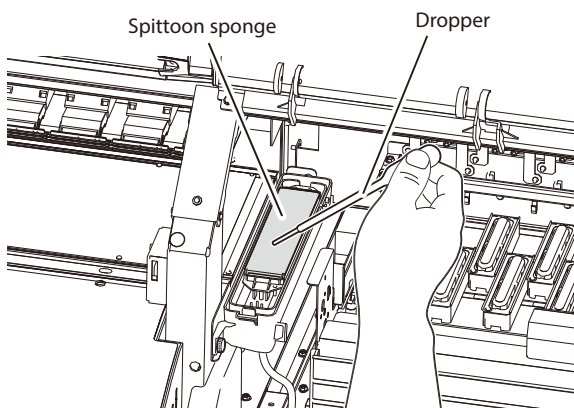

With a dropper, moisten the spittoon sponge with the spittoon absorber liquid.

10

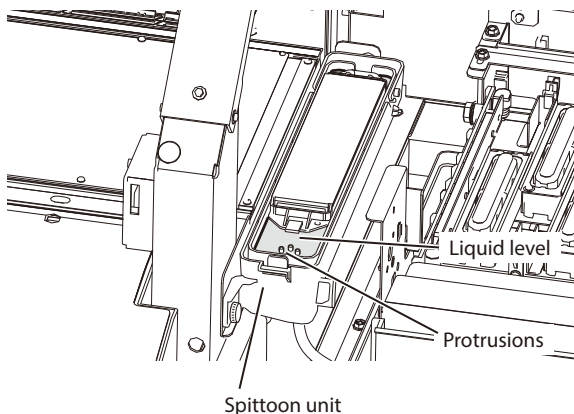

Pour the spittoon absorber liquid into the spittoon case until the liquid level is as high as the indication protrusions.

NOTE

- A few minutes after pouring the spittoon absorber liquid into the spittoon case, the spittoon absorber sponge absorbs the liquid and the liquid level is lowered. In such a case, again add the spittoon absorber liquid.

Cleaning the media edge guard

■ Operation location

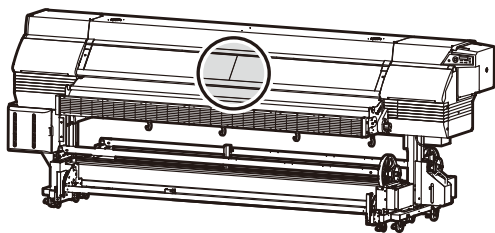

■ Required consumables

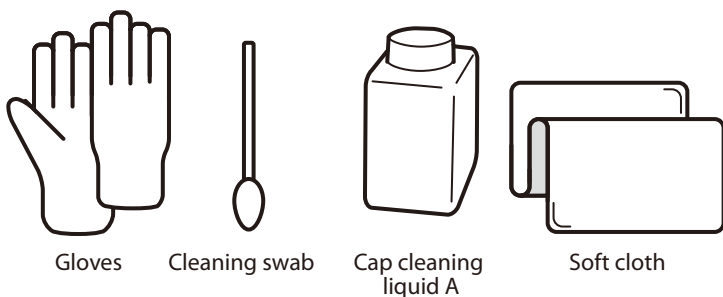

When executing cleaning of the media edge guards from the operation panel menu, start the procedure from step 1.
When cleaning the media edge guards while executing **#START MAINTENANCE**, start the procedure in step 6.



Press the **Right** button.



With the **Down** button scroll to **#MAINTENANCE**.



Press the **OK** button.



Press the **Down** button.



Select **MEDIA EDGE GUARD**, and press the **OK** button.



6

OPEN COVER



7

EDGE GUARD CLEANED?
YES: OK/NO: CANCEL



8

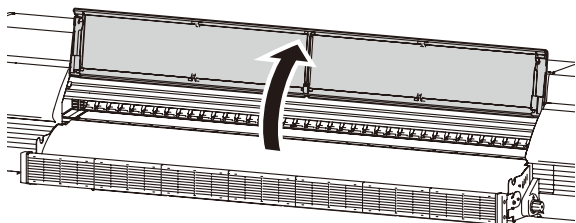

9

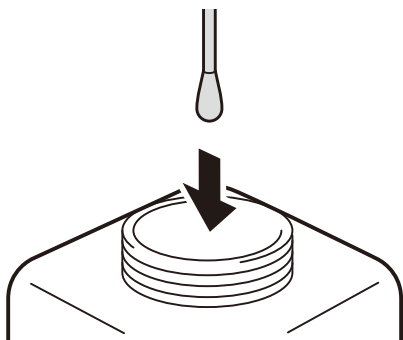

10

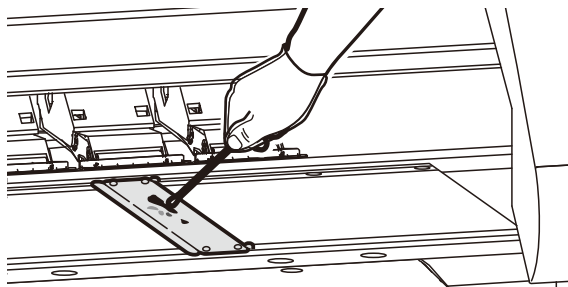

11

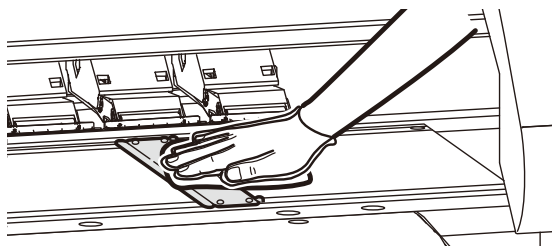

12

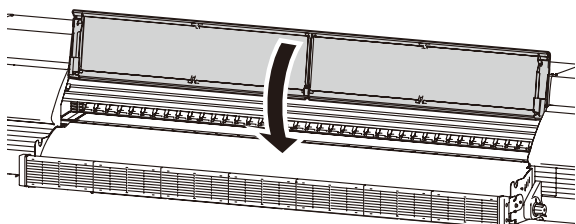

After you have finished the replacement procedure described from step 8, press the **OK** button.

Open the front cover.

Dip a cleaning swab in the cap cleaning liquid.



TIP

- To prevent the cap cleaning liquid from being contaminated, do not soak the cleaning swab after you clean with it in the cap cleaning liquid bottle.
- The cleaning swab is intended for a single use only. Use a new cleaning swab for each cleaning.

Checking visually for scrub stains on the media edge guard.



Clean the stains with a soft and clean cloth.



Close the front cover.

Replenish the wiper cleaning liquid

■ Operation location

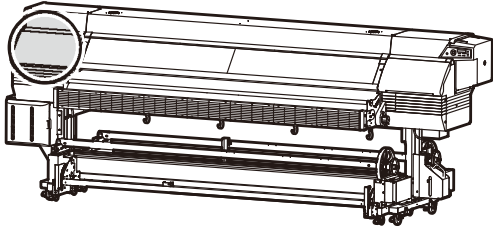

■ Required consumables

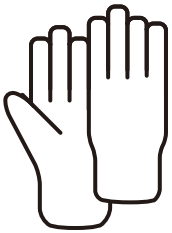

Gloves



Wiper cleaning liquid A



Funnel

When replenishing the wiper cleaning liquid from the operation panel menu, start the procedure from step 1. When replenishing the wiper cleaning liquid while executing **#START MAINTENANCE**, start the procedure in step 6.



Press the **Right** button.



With the **Down** button scroll to **#MAINTENANCE**.



Press the **OK** button.



Press the **Down** button.



Select **WIPER LIQUID**, and press the **OK** button.

6

OPEN COVER



7

WIPER LIQUID CHECKED?
YES: OK/NO: CANCEL



8

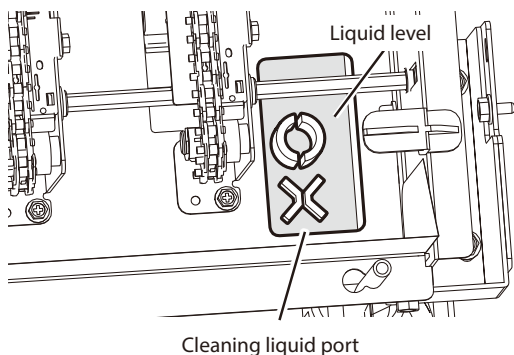

After you have finished the replacement procedure described from step 7, press the **OK** button.

Check the wiper cleaning liquid level.

Check that the cleaning liquid supply hole is at the top face's lower right of the wiping unit.



Two types of bottle

- Wiper cleaning liquid is supplied in two different types of bottle. If you find it not convenient to directly replenish the liquid with the bigger 300 ml bottle, first transfer the liquid in the wiper cleaning liquid bottle of 200 ml included in the daily maintenance kit to make the operation easier.

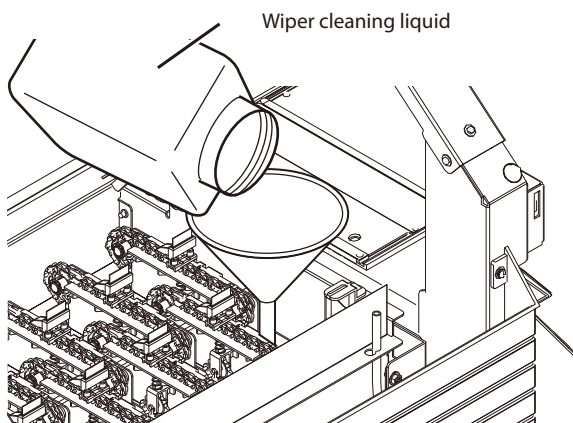

When the cleaning liquid level is lower than the **X** mark's top edge, replenish the wiper cleaning liquid.

Replenish the liquid so that the cleaning liquid level is lower than the **O** mark's top edge.



9

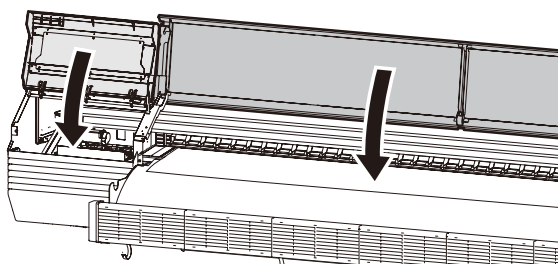

Close the wiping cover and the front cover.

CAUTION

- Be sure to unlock the stopper before closing the wiping cover. If you try to close the wiping cover without unlocking the stopper, the stopper may bend, or the bent stopper may touch the carriage, which may damage the Printer.

Check for dirt or damage on the wiper blade

■ Operation location

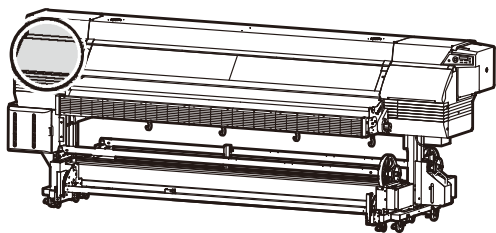

■ Required consumables

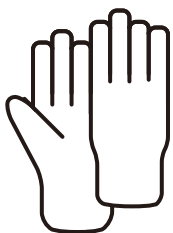

Gloves

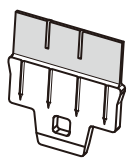

Wiper blade



Tweezers

When checking the wiper blade from the operation panel menu, start the procedure from step 1. When checking the wiper blade while executing **#START MAINTENANCE**, start the procedure in step 6.



Press the **Right** button.



With the **Down** button scroll to **#MAINTENANCE**.



Press the **OK** button.



Press the **Down** button.



Select **WIPER BLADE**, and press the **OK** button.



6 OPEN COVER



7 WIPER BLADE CHECKED?
YES: OK/NO: CANCEL

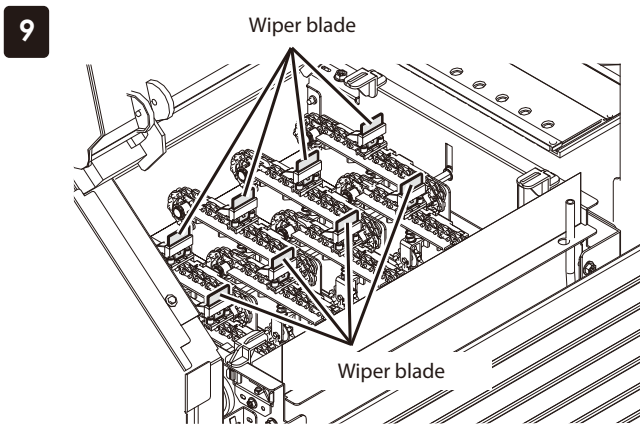
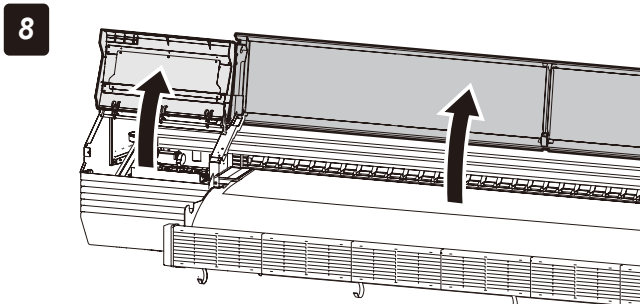

After you have finished the replacement procedure described from step 8, press the **OK** button.

Open the front cover, and then open the wiping cover.

Visually check the wiper blade for contamination and scratches.

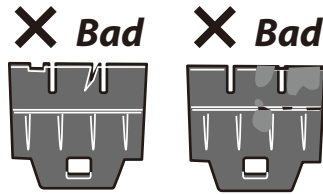

If the wiper blade is stained or scratched, replace it.
See **Replace a wiper blade** on the **page 131**.

Check the head guard cleanliness

■ Operation location

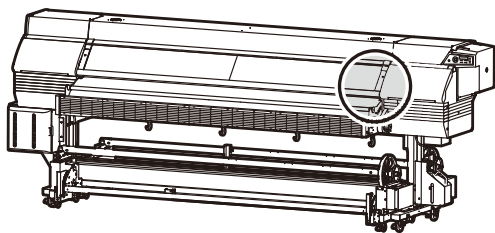

■ Required consumables

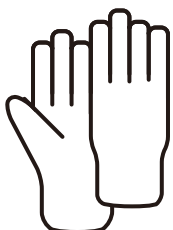

Gloves



Cleaning swab



Cap cleaning liquid A

When executing cleaning of the head guard from the operation panel menu, start the procedure from step 1. When cleaning the head guard while executing **#START MAINTENANCE**, start the procedure in step 6.



Press the **Right** button.

With the **Down** button scroll to **#MAINTENANCE**.

Press the **OK** button.

Press the **Down** button.

Select **PRINT HEAD GUARD**, and press the **OK** button.

6

CARRIAGE MOVING
PLEASE WAIT



7

OPEN COVER
RESEAT PRINTHEAD



8

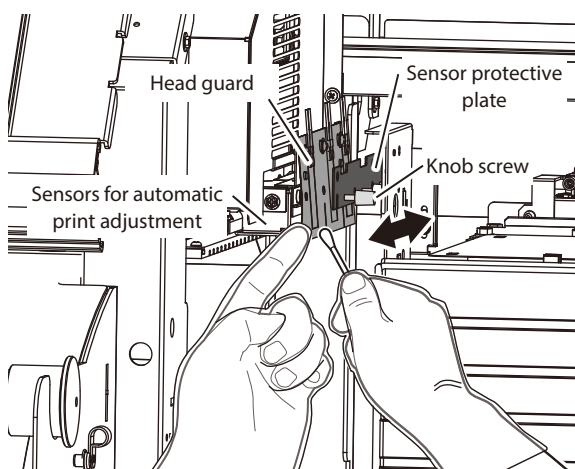
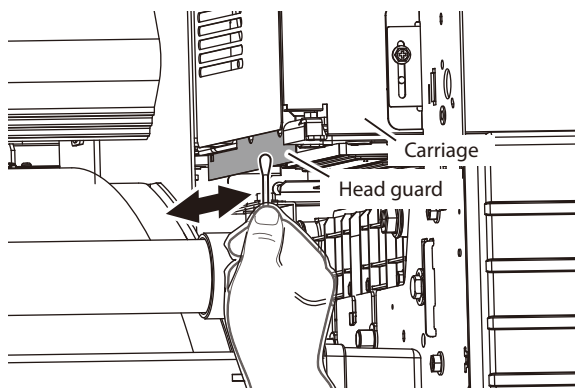

The carriage moves to the wiping unit side.



The Printer issues an audio warning beep.

- When the carriage moves, the Printer issues an audio warning beep.
- To unactivate the warning beep, see the *Advanced Operation Guide* on the page 48.

Clean the head guard at the right and left sides of the carriage using a cleaning swab or a soft cloth.



Is it difficult to reach the rear side?

- If it is difficult to reach the head guard rear side to clean it, remove the spittoon unit.

To clean the head guard on the right side of the carriage, remove the knob screw and the sensor protective plate, and keep the head guard at a tilt.

CAUTION

- Do not apply excessive strength when tilting the head guard.
- Pay attention no to touch the sensors for automatic print adjustment with the cleaning swab extremity.
- Pay attention no to touch the harness at the top of the head guard with the cleaning swab extremity.

After cleaning, return the head guard and the sensor protective plate to their original position and securely tighten the knob screw.

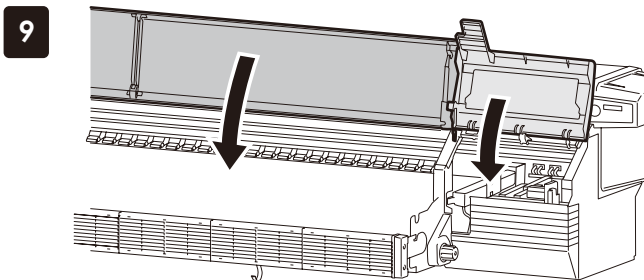

Close the capping cover and the front cover.

The print head returns automatically to the home position.

! CAUTION

- Be sure to unlock the stopper before closing the capping cover. If you try to close the capping cover without unlocking the stopper, the stopper may bend, or the bent stopper may touch the carriage, which may damage the Printer.



Press the **OK** button.

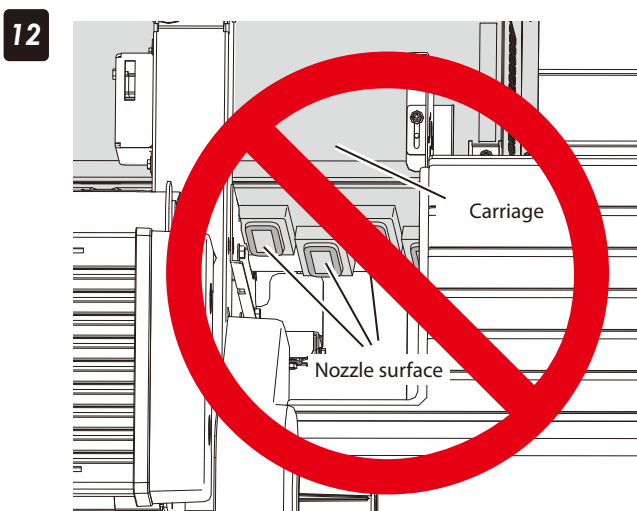

Do not clean directly the nozzle surfaces.
(Execute the dedicated sheet mount cleaning to clean them.)

! CAUTION

- Do not rub the head nozzle surface with a cleaning swab. It may cause a Printer failure.

Clean the surface of the sensors for automatic print adjustment

■ Operation location

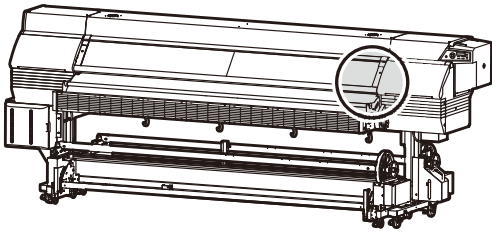

■ Required consumables

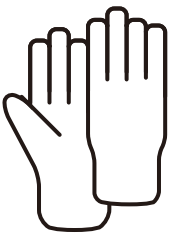

Gloves



Cleaning swab

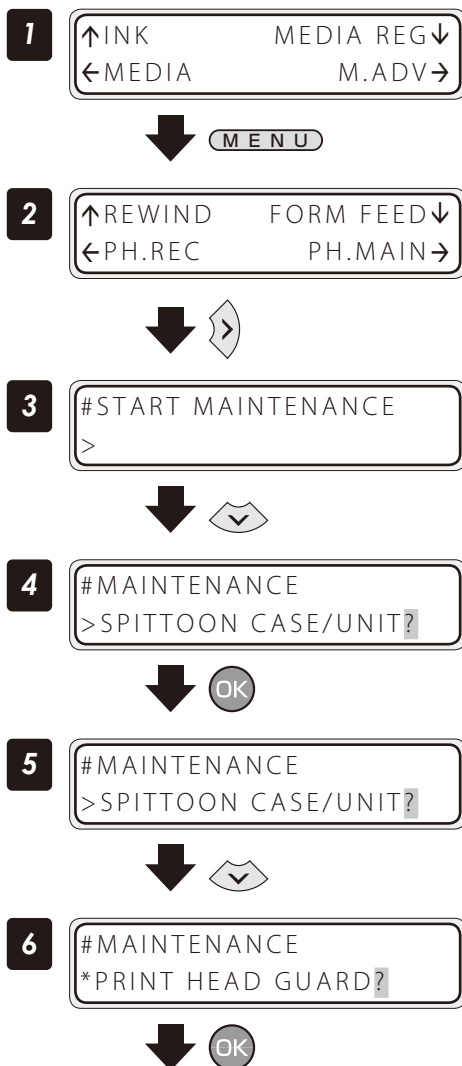

Set the Printer to offline state, and press the **MENU** button.

Press the **Right** button.

With the **Down** button select **#MAINTENANCE**.

Press the **OK** button.

Press the **Down** button.

Select **PRINT HEAD GUARD** and press the **OK** button.

7 CARRIAGE MOVING
PLEASE WAIT



8 OPEN COVER

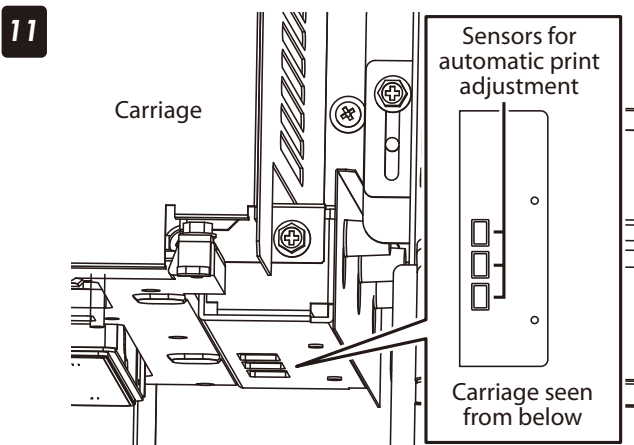
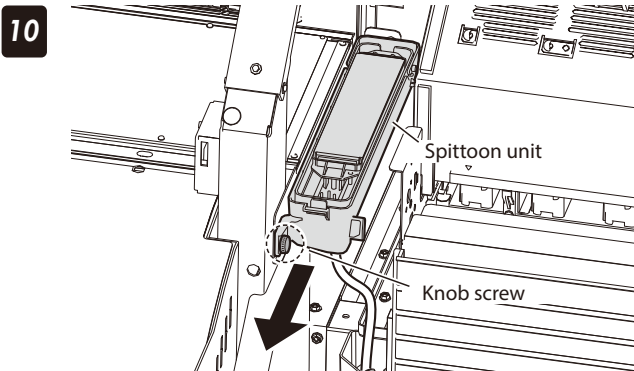
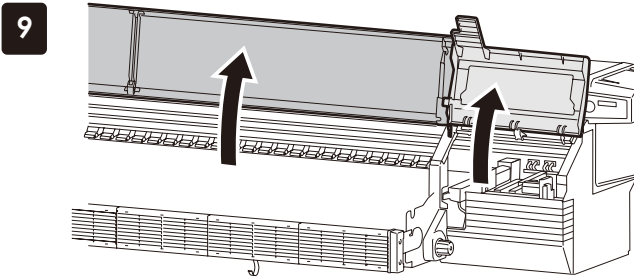

The carriage moves above the spittoon unit.



The Printer issues an audio warning beep.

- When the carriage moves, the Printer issues an audio warning beep.
- To unactivate the warning beep, see the **Advanced Operation Guide** on the **page 48**.

Open the front cover, and then open the capping cover.

Remove the knob screw from the spittoon unit and remove the spittoon unit.



- Do not soak the cleaning swab used for cleaning into the cap cleaning liquid bottle. Otherwise, the cap cleaning liquid may get dirty.
- Cleaning swabs are intended for a single use only. Use a new cleaning swab for each cleaning.

Move the carriage manually to the position of the spittoon unit, and then clean the surface of the sensors for automatic print adjustment using a cleaning swab.

CAUTION

- Use the cleaning swab without any cleaning solution when cleaning the surface. Otherwise, the sensors may be damaged.

12

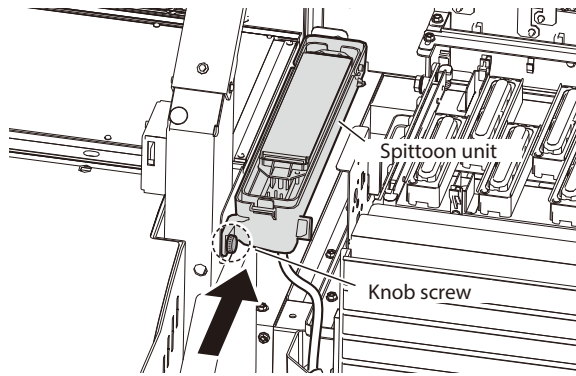

Move the carriage manually to above the platen (on the left side) and reinstall the spittoon unit using the knob screw.

13

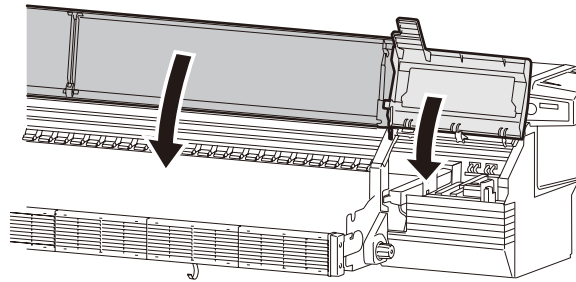

Close the capping cover and the front cover.

The print head returns automatically to the home position.

CAUTION

- Be sure to unlock the stopper before closing the capping cover. If you try to close the capping cover without unlocking the stopper, the stopper may bend, or the bent stopper may touch the carriage, which may damage the Printer.

14

CARRIAGE MOVING
PLEASE WAIT



15

CLEAN HEAD GUARD?
YES: OK/NO: CANCEL



Press the **OK** button.

Clean the capping unit

■ Operation location

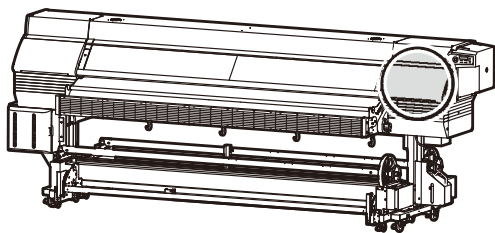

■ Required consumables

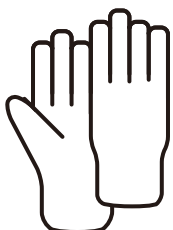

Gloves



Cleaning swab (thick)



Cap cleaning liquid A

⚠ CAUTION

To prevent the ink from drying inside the print head's nozzles:

- Do not leave the Printer with the carriage detached from the capping unit.
- Within 5 minutes, complete the capping unit's cleaning operation and cap the print head.

1

START CAP CLEANING?
OK/CANCEL



Press the **OK** button.

2

1ST WIPING OPERATION
PLEASE WAIT XXX

XXX: Required time (the time is counted down every 10 seconds)



The carriage moves to the wiping unit side.



The Printer issues an audio warning beep.

- When the carriage moves, the Printer issues an audio warning beep.
- To unactivate the warning beep, see the **Advanced Operation Guide** on the **page 48**.

OPEN COVER
CLEAN CAP

3

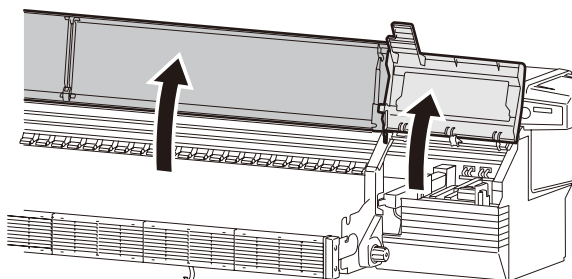

Open the front cover and then open the capping cover.

4

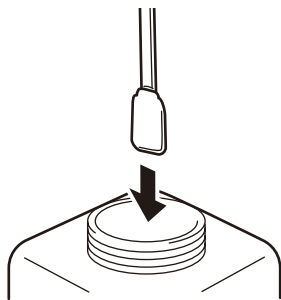

CLEAN CAP
CLOSE COVER

5

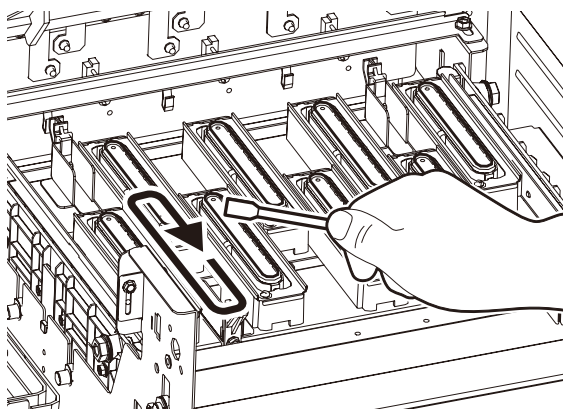

CAUTION

- Be careful so that the cap cleaning liquid does not adhere to any part other than the cap.
- Be careful not to hit the metal plate with your hand when cleaning the caps with the cleaning swab (thick).

6

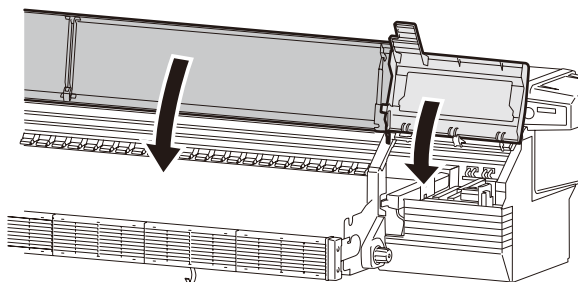

Soak the cleaning swab (thick) in the cap cleaning liquid.



TIP

- To prevent the cap cleaning liquid contaminated, in the cap cleaning liquid bottle do not soak the cleaning roller after you clean the cap with it.
- The entire capping unit can be cleaned using a single cleaning swab (thick) soaked only once in the cap cleaning liquid.

Clean the top surface of the caps by using the cleaning swab (thick).



1. First, pass the cleaning swab (thick) over the entire circumference of each cap top surface to impregnate the dirt on the surface with cap cleaning liquid. Pass the cleaning swab (thick) starting from the leftmost cap and continue to the rightmost cap.

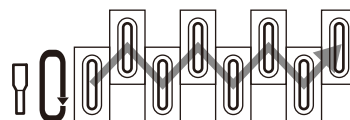

2. Next, clean all the dirt by passing a cleaning swab (thick) five times over the circumference of each cap top surface. Start from the leftmost cap and continue to the rightmost cap.

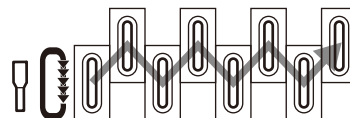

TIP

- The cleaning swab (thick) is intended for a single use only. Use a new cleaning swab (thick) for each cleaning.

Close the capping cover and the front cover.

The print head returns automatically to the home position.

CAUTION

- Be sure to unlock the stopper before closing the capping cover. If you try to close the capping cover without unlocking the stopper, the stopper may bend, or the bent stopper may touch the carriage, which may damage the Printer.



The missing dots persist even after the cap cleaning...

- If you still see the missing dots even after the cap cleaning above, while checking visually remove foreign matters and ink stains from the cap with a cleaning swab dampened with cap cleaning liquid.

7

2ND WIPING OPERATION
PLEASE WAIT XXX

XXX: Required time (the time is counted down every 10 seconds)



8

CAP CLEANED?
YES: OK/NO: CANCEL



Press the **OK** button.

A message prompting you to check the waste ink bottle is displayed.

Check the waste ink bottle

■ Operation location

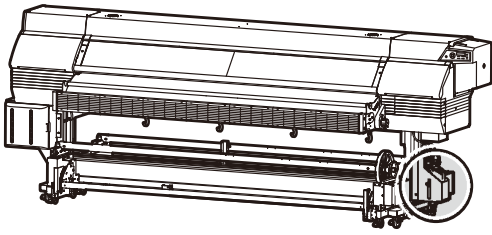

■ Required consumables

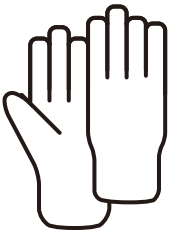

Gloves

1 CHECK WASTE BOTTLE
*OK?



2 Check visually that the waste ink bottle is not full. If the waste ink level is as high as the **FULL** indication label, replace the bottle with an empty waste ink bottle.

See **Replace a waste ink bottle** on the  **page 127**.

CHECK FOR CLOGGED
NOZZLE BEFORE PRINT

The start maintenance ends with the waste ink bottle check.

Execute the following normal cleaning and nozzle check from the operation panel.

Press the **OK** button.

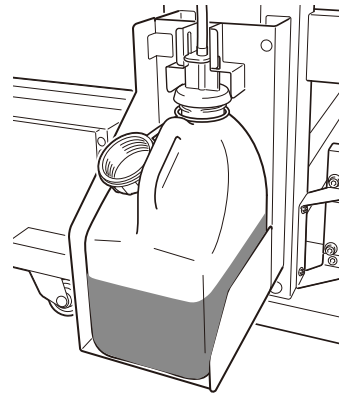

Performing normal cleaning

■ Operation location

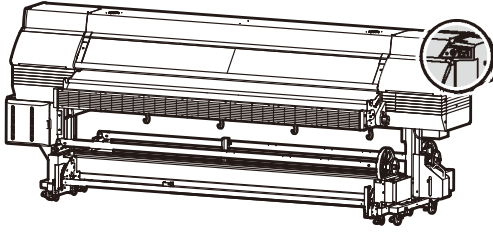

1

↑INK	MEDIA REG↓
←MEDIA	M.ADV→



2

↑REWIND	FORM FEED↓
←PH.REC	PH.MAIN→



3

#PH RECOVERY
>NORMAL



4

#PH RECOVERY
*NORMAL



Set the Printer to offline state, and press the **MENU** button.

Press the **Left** button.

Press the **OK** button.



- When a specific length of media has been printed since the last cleaning operation, **NORMAL** (normal cleaning) is not displayed. In such a case, perform **STRONG** (strong cleaning). (See the *Advanced Operation Guide*, on the **Strong cleaning**  **page 66**.)

Press the **OK** button.

5

#SELECT: 87654321FB
*BOTTLE OK?



6

#PH REC 87654321FB
*BOTTLE OK?



#PH RECOVERY
*CLEANING 12

This value is counted down every 10 seconds.

7

#PH RECOVERY
>NORMAL



↑REWIND FORM FEED↓
←PH.REC PH.MAIN→

Press the **OK** button.

The indicated number denotes the head to be cleaned.

The ink colors and print head numbers correspondence is shown in the table below.

Lg	M	Lc	K	Gy	C	Lm	Y
8	7	6	5	7	3	2	1



- When a specific length of media has been printed since the last cleaning operation, print heads cannot be selected and cleaned individually.

Press the **OK** button.

Check visually that the waste ink bottle is not full. If the waste ink level is as high as the **FULL** indication label, replace the bottle with an empty waste ink bottle.

See **Replace a waste ink bottle** on the **page 127**.

Start the print head cleaning.

Print head cleaning takes several minutes.

When the cleaning starts, the required time is displayed and the time is counted down every 10 seconds.

Press the **Left** button.

The Printer returns to the offline state, that is, menu mode.

Print the nozzle print pattern

■ Operation location

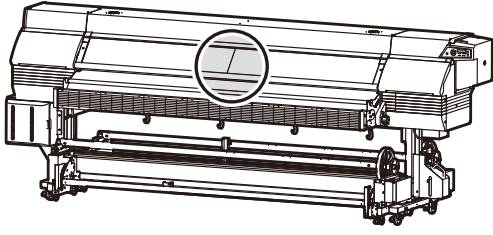

Use NOZZLE PRINT to check if any print head nozzles (ink ejection outlet) are clogged. Perform a NOZZLE PRINT every day to check the print heads before printing or after the capping unit has been detached to perform a cap cleaning or other operation.

1

↑INK	MEDIA REG↓
←MEDIA	M.ADV→

↓ MENU x2

2

↑PRINTER	SETUP↓
←ADJUST	HEATER→

↓ <

3

#NOZZLE PRINT
#EXECUTE

↓ >

4

#NOZZLE PRINT
#EXECUTE

↓ OK

5

#NOZZLE PRINT
#EXECUTE>OK?

↓ OK

6

#NOZZLE PRINT
*EXECUTING

Set the printer to offline state and press the **MENU** button twice.

Press the **Left** button.

Press the **Right** button.

Press the **OK** button.

Press the **OK** button.

7 Check for missing dots and incorrect print.
The following pattern is printed.

- Nozzle print sample

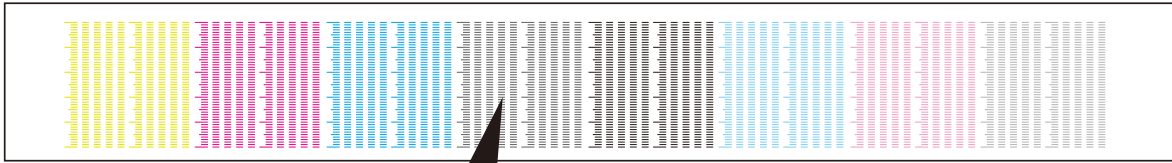

✓ GOOD **No line is missing and the printout is correct**

Mark for the last nozzle (nozzle 508)
Check that nozzle print is complete up to the right of this mark.

⊘ BAD **Missing lines are found**

Example when lines for nozzles 24 and 133 are missing in the printout.

The numbers of the nozzles for which nozzle map has been set are written in this area.

✓ GOOD **No line is bent and the printout is correct**

If the spaces between the lines are even, no line is bent.

⊘ BAD **Bent lines are found**

If there are uneven spaces between lines, some lines may be bent.

Example: Bent lines are found

Check that there are no missing or bent lines.

If missing or bent lines are found with the nozzle print, perform the normal cleaning.

If missing or bent lines remain after several normal cleanings, set **NOZZLE MAP** with the procedure below.

Nozzle map setting

- 

1 #NOZZLE PRINT
#EXECUTE
- 

2 #NOZZLE PRINT
#NOZZLE MAP 01 Gy4>000
- 

3 #NOZZLE PRINT
#NOZZLE MAP 01 Gy4*000
- 

4 #NOZZLE PRINT
#NOZZLE MAP 01 Gy4*224
- 

5 #NOZZLE PRINT
#NOZZLE MAP 01 Gy4>224

Press the **Up** or **Down** button several times to select nozzle map.

Up to 10 nozzles can be set with nozzle map for each print head.

Press the **OK** button.

Here, nozzle map 01 is set for print head Gy4.

Select the digit with the **Right** or **Left** button and set the value using the **Up** or **Down** button.

Press the **OK** button.

The setting is complete.



To check the numbers of the nozzles with nozzle map

- The numbers of the nozzles for which nozzle map has been set are indicated on the nozzle print pattern printout.

After today's operation

The Printer has an internal clock which allows it to wash the print heads automatically, flushing some ink through the print heads, which keeps the print heads in good condition. To ensure the Printer's automatic maintenance operation, after today's operation keep your Printer on the conditions below.

1. Never turn the Printer off.

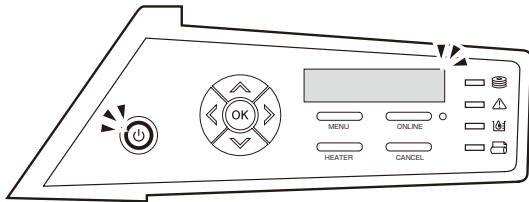

2. Keep the front cover closed.



NO

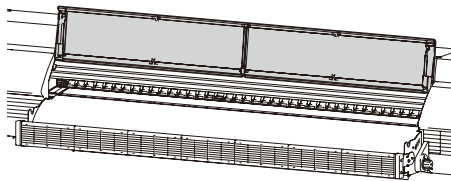

YES

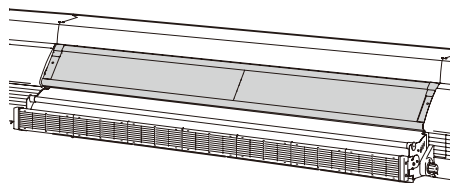

3. Take up the media on the Printer, or unload the media from the Printer.

If you keep the media loaded on the Printer for a long time, the media may be wrinkled on the platen or the media gripping trace may be left. To keep the media in good condition, the operation below is recommended. Especially after printing on Vinyl, be sure to unload it from the Printer. Note that Vinyl wrinkles frequently.

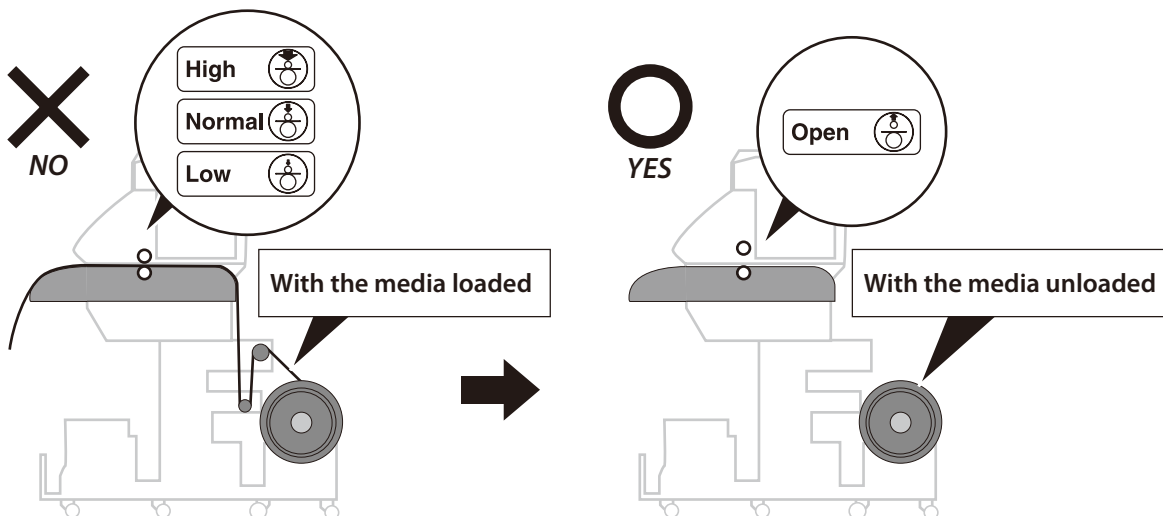

Sheet mount cleaning

Check the nozzle surfaces of the print heads for dirt. If the surfaces are dirty, clean them using a print head cleaning sheet.

A message prompts you to clean the nozzle surfaces every month or after 600 m of printing.

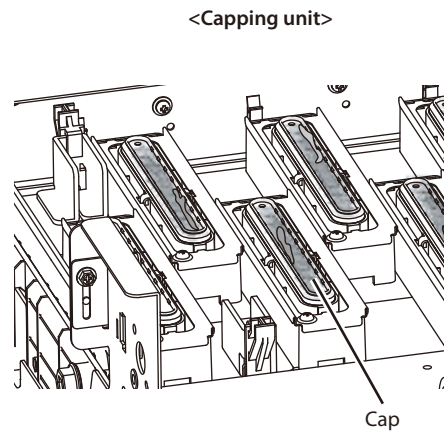
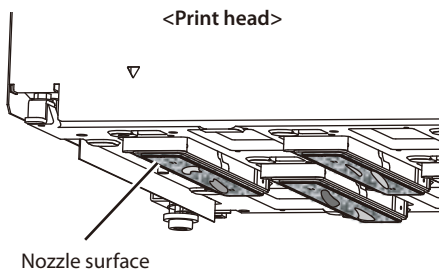

CAUTION

- Do not wipe the print heads nozzle surfaces with a cleaning swab as it may cause print head malfunction.

■ Operation location

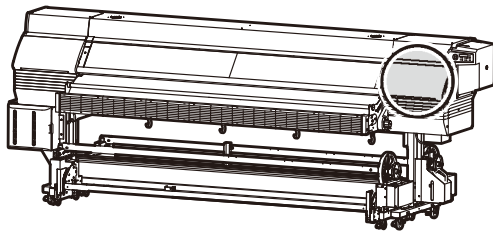

■ Required consumables

Sheet mount cleaning liquid A

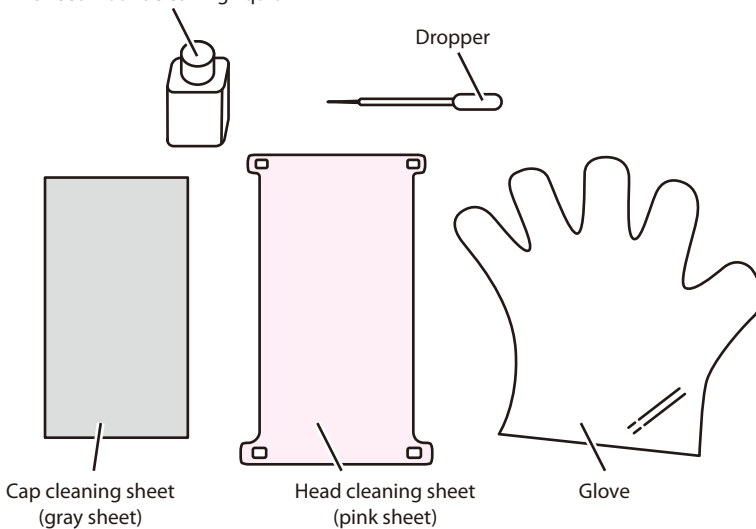

1 ↑INK MEDIA REG↓
←MEDIA M.ADV→



2 ↑REWIND FORM FEED↓
←PH.REC PH.MAIN→



3 #START MAINTENANCE
>



4 #SHEETMOUNT CLEANING
>



5 #SHEETMOUNT CLEANING
*OK?



CARRIAGE MOVING
PLEASE WAIT

↓ Carriage stops moving.

6 OPEN COVER

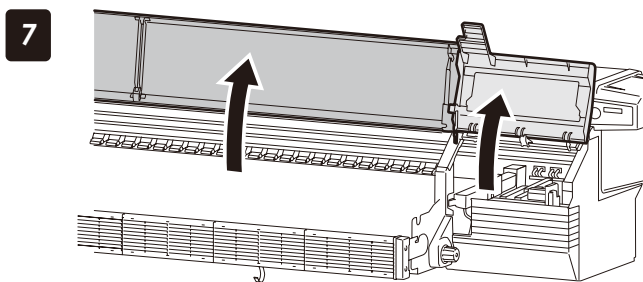

Set the Printer to offline state, and press the **MENU** button.

Press the **Right** button.

With the **Down** button select **#SHEETMOUNT CLEANING**.

Press the **OK** button.

Press the **OK** button.

Open the front cover and then open the capping cover.

8

INSTALL GRAY SHEET
OK?

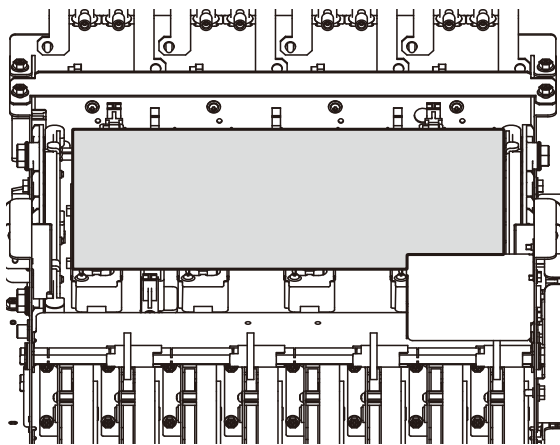

Place the gray sheet (cap cleaning sheet) to cover all eight caps.

Press the **OK** button.

9

DRIP CLEANING LIQUID
ON GRAY SHEET. OK?

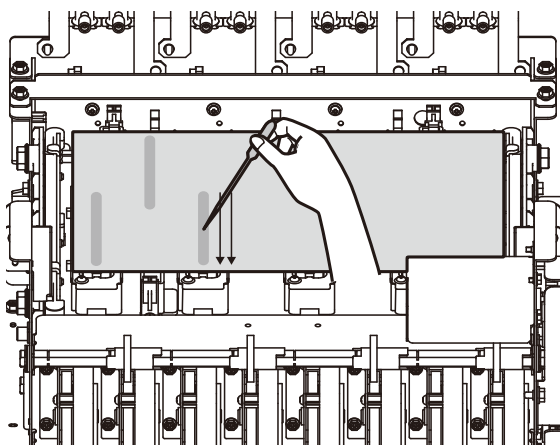

Apply 1 cc of cleaning liquid twice to the sheet for each cap.

Draw 1 cc of sheet mount cleaning liquid with the dropper (use the gradations), and apply 2 cc to the gray sheet (capcleaning sheet) for each color. Apply the liquid parallel twice over the caps.

Press the **OK** button.

10

INSTALL PINK SHEET
OK?

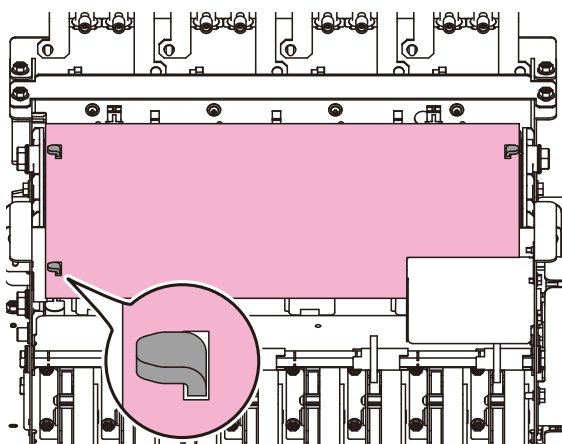
**11**

CLOSE COVER



CARRIAGE MOVING
PLEASE WAIT



Carriage stops moving.

! CAUTION

- If the current procedure is interrupted by an error before the step 11, start sheet mount cleaning again from step 1.

12

CLEANING...
TIME REQUIRED XX:XX



The sheet mount cleaning is complete.

Place the pink sheet (head cleaning sheet) over the gray sheet and attach the hooks.

! CAUTION

- Securely attach the four hooks. Otherwise the sheet may detach when entering into contact with the print heads, which decreases the effectiveness of the cleaning.
The four hooks are placed at the four corners of the capping unit as shown in the figure to the left.

Press the **OK** button.

Close the capping cover and the front cover.

! CAUTION

- The recommended time for sheet mount cleaning is 1 hour. The cleaning may be less effective if the recommended time is not respected.



To interrupt the sheet mount cleaning

- Press the **CANCEL** button.

CANCEL SHEET MOUNT
CLEANING OK?

Press the **OK** button.

Go to **14**.

13 CLEANING COMPLETE
PRESS OK BUTTON



CARRIAGE MOVING
PLEASE WAIT



Carriage stops moving.

14 OPEN COVER

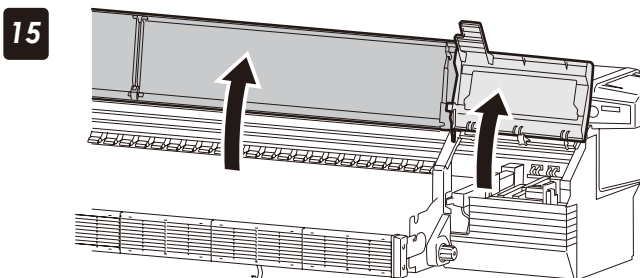

Open the front cover and then open the capping cover.

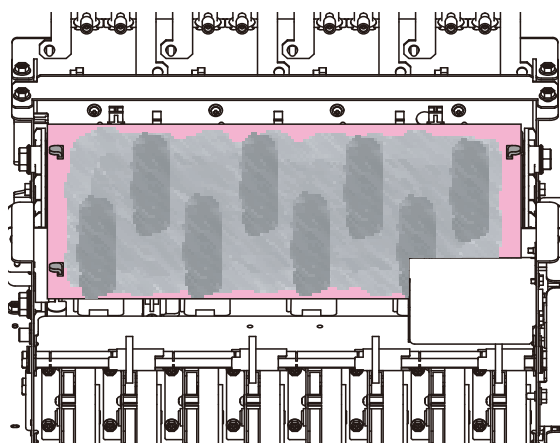

16 REMOVE PINK SHEET
OK?



Remove the pink sheet (head cleaning sheet) and press the **OK** button.

17 REMOVE GRAY SHEET
OK?



Remove the gray sheet (cap cleaning sheet) and press the **OK** button.

18 CLOSE COVER



CARRIAGE MOVING
PLEASE WAIT



Carriage stops moving.

19 START CLEANING
BOTTLE IS EMPTY?



CLEANING XXXXXXXX
PLEASE WAIT * * *



The cleaning is complete.

#SHEETMOUNT CLEANING
>

Close the capping cover and the front cover.

Press the **OK** button.

Check visually that the waste ink bottle is not full.

Sheet mount cleaning is complete.

CAUTION

- If the current procedure is interrupted by an error before you remove the pink sheet and the gray sheet, follow the procedure below to remove the sheets.

1. Move the carriage to the maintenance area.
2. Open the front cover, and then the capping unit cover.
3. Remove the pink sheet and the gray sheet that remained on the caps.
4. Close the capping unit cover, and then the front cover.
5. Move the carriage to the home position.
6. Perform a strong cleaning.

(See the *Advance Operation Guide*  **page 65** for how to perform a **Strong cleaning**.)

Introduction

For your basic operation

Maintenance

When encountering a problem

Appendix

When encountering a problem



Check your problem

Before deciding that there is a serious problem with the Printer, check the following items.

Power is not turned on.

Items to be checked	Corrective measures
● Power cable connection	Check that the power cable is correctly plugged into the power outlet.
● Power supply to the outlet	Supply power to the power outlet.
● Power switch on/off	Turn on the power switch. See Turn the Printer on on the  page 29 .





The paper guide is not heated even when the heater is turned ON.

Items to be checked	Corrective measures
● Printer status	The paper guide is heated during Printing or when the heater is turned on with the heater control menu. Be sure the paper guide is heated by printing the nozzle print pattern or set the heater to ON . See Advanced Operation Guide, Adjust the heaters' temperature on the  page 69 .
● Host computer RIP setting	The heater temperature can be set also by the RIP of the host computer. Check the host computer setting.
● Heater control menu	Turn on the heater (afterheater/printheater/preheater) again, and then print nozzle print pattern or forcibly set the heater to ON to check that the paper guide is heated. See Advanced Operation Guide, Adjust the heaters' temperature on the  page 69 .
● Power voltage	Connect the Printer to 200 VAC power.

The printer fails to start or operate correctly.

Items to be checked	Corrective measures
● ERROR LED and LCD message on the operation panel	See When an error message is displayed on the  page 116 .

The Printer cannot print.

Items to be checked	Corrective measures
● USB cable connection	Connect the USB cable correctly. See To connect USB cable on the  page 28 .
● ERROR LED and LCD message on the operation panel.	See When an error message is displayed on the  page 116 .
● Error LED OFF	Print the nozzle adjustment pattern. See Print the nozzle print pattern on the  page 101 . (Confirm that the RIP software Test pattern is printed.)
● Print head cleaning	Clean the print head. See Performing normal cleaning on the  page 99 .





Although the Printer is in the print mode, printing does not start with **PREHEATING** displayed on the operation panel.

Items to be checked	Corrective measures
● Room temperature	Raise the room temperature. (Recommended temperature: 20 to 25°C)
● Affect of air flow	If the air from the air conditioner or fan is blowing against the paper guide, avoid the air flow (by changing air flow direction, orientation of the Printer, or the location of the Printer).

The transmitted data is not printed.

Items to be checked	Corrective measures
● ONLINE LED (flashing?)	Check the communication conditions to the host computer.

Media jams occur frequently.

Items to be checked	Corrective measures
● Media type	Check whether the media type setting matches the type of media loaded. See To print on other media on the  page 50 .
● Media loading	Install the media properly. See To load media on the Printer on the  page 31 .
● Obstructions in the carriage path or the media path	Remove any obstructions. See How to clear media jams on the  page 115 .
● Suction fan power	If the suction fan power is not proper, reduce the power. See Advanced Operation Guide, Prevent the media from sticking and wrinkling on the  page 30 .
● Heater temperature setting	If the heater temperature is not best set, lower the heater temperature. See Advanced Operation Guide, Adjust the heaters' temperature on the  page 69 .

Print quality is poor.

See **Advanced Operation Guide, Troubleshoot print quality issues** on the  **page 55**.

Blank sheet appears.

Items to be checked	Corrective measures
● Print data	Check the current print data to confirm that you sent the blank sheet's data.

Printing is slow. The carriage sometimes moves.

Items to be checked	Corrective measures
● USB connection speed	<p>When the data transmission speed is slow, the Printer waits for the data with the print heads capped.</p> <p>Check the USB's transmission speed. If the USB is connected at full speed mode, the speed is improved by changing the condition to connect to the computer as follows, so that it is connected at high speed mode.</p> <ul style="list-style-type: none">- Re-connect the USB cable.- Connect the USB cable to the USB 2.0 port.- Re-install the driver.- Change the USB cable to the one supporting the high speed transmission.- If a hub is applied, change the hub to the one supporting the high speed transmission.

Printing is slow. During print, print heads are capped frequently.

Items to be checked	Corrective measures
● High-temperature environment	<p>If the Printer temperature is 40°C or more, the Printer prints at a lower printing speed. Set the ambient temperature to 20 to 25°C (recommended temperature), and hold the Printer for one hour or more. Then start printing.</p>
● Exhaust fan filters encrusted with dust.	<p>Replace the exhaust fan filters.</p> <p>See Replace the exhaust fan filters on the  page 74.</p>
● Computer specification	<p>Remove the additional device connected to the USB.</p>
● Computer specification	<p>Connect to the computer satisfying the recommended operational environment for your RIP software. For the recommended operational environment, contact the manufacturer of your RIP software.</p>
● Computer's additional job processing	<p>Terminate the other application software, for example, anti-virus software.</p>

You cannot understand the current operation panel display language.

Items to be checked	Corrective measures
● Language setting	<p>Turn on the power switch while pressing the MENU button to start the printer. The language setting menu appears. Set the language you want to use.</p>

Clogged nozzles cannot be restored.

Items to be checked	Corrective measures
● Ragged media edges	<p>If the media is ragged with some sections coming out from the edge guards, it may contact the heads nozzle surfaces and cause nozzles to clog.</p> <p>Cut any ragged sections with a pair of scissors or a cutter before installing the media.</p>
● Adhesive coming off the vinyl causing the media to rise up	<p>Feed the media to beyond the risen area.</p>
● Media wrinkling and rising up	<p>Set the suction fan level to HIGH.</p> <p>Decrease the printhead temperature.</p>
● Media adhering to the platen	<p>Set the suction fan level to LOW or OFF to make it advance again.</p> <p>Setting media advance mode to BACK & FWD 1 may also prevent the media from adhering to the platen.</p>
● Daily maintenance	<p>Check that the daily maintenance has been executed and that it is performed periodically.</p>

How to clear media jams

If the printer reports a media jam, follow these steps.

1 WARNING! X
CLEAR MEDIA JAM

The message appears.

X: Media jam type	Meaning
0: Media jam 0	A jam on the media feed path is invalidating the Printer's normal operation.
1: Media jam 1	A jam on the carriage is invalidating the Printer's normal operation.
2: Media jam 2	The media was not detected correctly because: <ul style="list-style-type: none"> - Roll media or cut-sheet media was selected incorrectly. - The length of the applied cut-sheet media is not as prescribed.
3: Media jam 3	The Printer cannot operate properly due to media wrinkles or other obstructions on the carriage path.

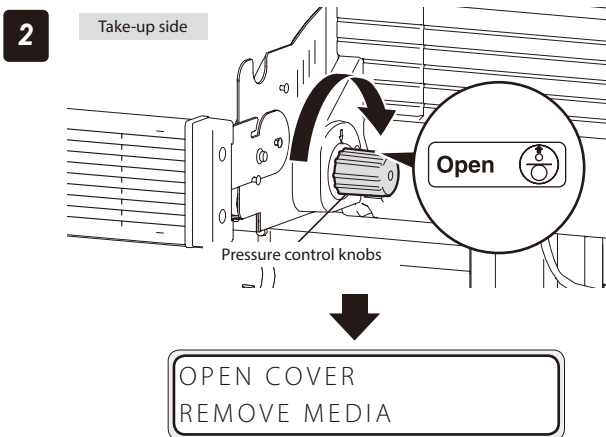

Rotate the pressure control knob, and set it to **Open**, and then open the front cover.

3 Move the carriage manually to remove the media that caused the jam, and then make sure that no obstruction is left in the carriage path and the media feed path.

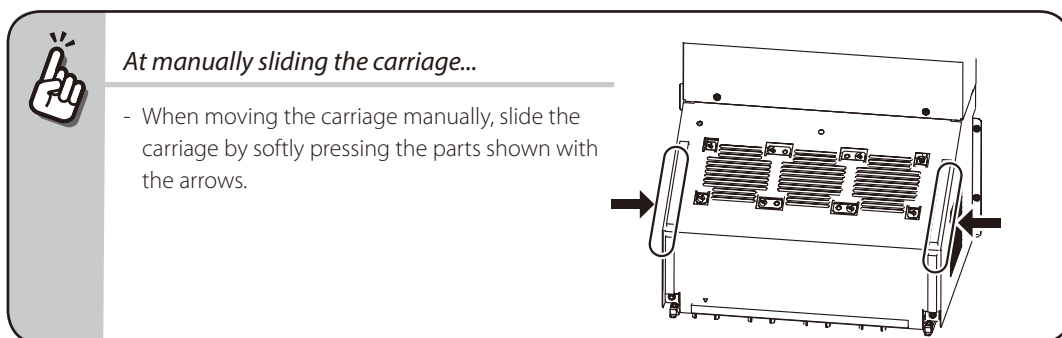

4 CARRIAGE MOVING
PLEASE WAIT

Close the front cover.

The carriage moves to the home position.

5 Again load the media on the Printer. See **To load media on the Printer** on the **page 31**.

When an error message is displayed

When the ERROR LED lights up, check the message displayed on the operation panel display. Error messages shown below are classified into two groups.

Service call errors:

Errors that the operator (customer) cannot recover, such as hardware or software failures. Contact your service representative.

Operator call errors:

Errors that the operator (customer) can recover. To recover the error, follow the advice described here.

Service call errors



Restart the Printer.

- If a service call error appears, restart the Printer by turning off and on as follows. Then the error may often be recovered.
 - (1) Turn off the operation panel's POWER switch, as well as the printer power switch and heater power switch at the rear of the Printer.
 - (2) Remove the two power cords from the socket. Then at the Printer rear, remove the two power cords from the printer power inlet and the heater power inlet.
 - (3) Hold the Printer for one minute or more.
 - (4) Connect each power cord above to its inlet, then connect the two cords to the socket.
 - (5) Turn on the all three switches above.

(System error)

SYSTEM ERROR n n n n
RESTART

nnnn: Error code

Meaning	An unrecoverable error occurred.
Action	Contact your service representative, and inform them of the displayed error code.



When the system error 2e0x is displayed

- You can perform the following procedure to use the Printer temporarily. However, when this error occurs, contact your dealer or your service representative without delay.

1

Turn the Printer off.

2

Wait at least 5 seconds after turning the Printer off, and then turn it on.

3

PRINTER READY
ROLL: 1625 / PAPER

You can use the Printer normally when the message on the left is displayed on the panel.

OPEN SUBCART COVER
XXX CHECK SUBCART

nn: Ink error code
XXX: Ink color/location

Meaning A problem occurred with a subcartridge, or a genuine subcartridge was not identified.

Action You are advised to follow the message.

CHECK (COLOR)
XXX SUBCARTRIDGE

XXX: Ink color/location

Meaning The subcartridge color is not correct.

Action Install the correct subcartridge.

CHECK (KIND)
XXX SUBCARTRIDGE

XXX: Ink color/location

Meaning The subcartridge type is not correct.

Action Install the correct subcartridge.

CLOSE SUBCART COVER

Meaning The subcartridge cover is not closed.

Action You are advised to follow the message.

(Waste ink bottle errors)

BOTTLE OUT
INSTALL BOTTLE

Meaning No waste ink bottle is installed.

Action You are advised to follow the message.
See **Replace a waste ink bottle** on the  **page 127**.

BOTTLE FULL
REPLACE BOTTLE

Meaning The waste ink bottle is full.

Action You are advised to follow the message.
See **Replace a waste ink bottle** on the  **page 127**.

(Media jam errors)

WARNING! (0)
CLEAR MEDIA JAM

Meaning An obstruction was left in the media feed path and the Printer could not feed the media normally.

Action Set the pressure control knob to **Open**, and open the front cover. If the media jam (0) error occurs repeatedly although there is no media jam or no obstruction in the media feed path, contact your service representative.
See **How to clear media jams** on the  **page 115**.

WARNING! (1)
CLEAR MEDIA JAM

Meaning An obstruction was left in the carriage path and the Printer could not drive the carriage normally.

Action Set the pressure control knob to **Open**, and open the front cover. If the media jam (0) error occurs repeatedly although there is no media jam or no obstruction in the carriage path, contact your service representative.
See **How to clear media jams** on the  **page 115**.

WARNING! (2)
CLEAR MEDIA JAM

Meaning	The media was not detected correctly because: - the roll media or cut-sheet media was wrongly selected or - the length of the cut-sheet media used did not match the specified one.
Action	Set the pressure control knob to Open , and open the front cover. Besides, check that the settings are correct. See How to clear media jams on the  page 115 .

WARNING! (3)
CLEAR MEDIA JAM

Meaning	Media wrinkles or other obstructions were left in the carriage path and the Printer could not drive the carriage normally.
Action	Set the pressure control knob to Open , and open the front cover. If the media jam (0) error occurs repeatedly although there is no media jam or no obstruction in the media feed path, contact your service representative. See How to clear media jams on the  page 115 .

(Media errors)

NO MEDIA LOADED
LOAD MEDIA

Meaning	No media is loaded on the Printer.
Action	When there is no media, install new media. If the flange is not attached correctly, attach it correctly. See To load media on the Printer on the  page 31 .

LOAD MEDIA

Meaning	Media could not be detected.
Action	See To load media on the Printer on the  page 31 .

MEDIA SIZE ERROR
CHECK MEDIA

Meaning	Media of invalid width size (longer than 104 inches) was loaded.
Action	Load media of the specified size. See To load media on the Printer on the  page 31 .

OPEN COVER
CHECK MEDIA

Meaning	The thickness of the loaded media is not supported.
Action	Load media with the proper thickness.

MEDIA MISALIGNED
RELOAD MEDIA

Meaning	The media skewed.
Action	Reinstall the media correctly. Ink may have been discharged on the platen depending on the skew level. In that case, completely remove the ink from the platen. See To load media on the Printer on the  page 31 .

MEDIA MISALIGNED
OK/CANCEL

Meaning	Media skew was detected during printing.
Action	Continue to print or stop printing.

ROLL END DETECTED
PRINT/CANCEL

Meaning	Media end detected during printing.
Action	Continue to print or stop printing. (See  page 41 in the Advanced Operation Guide for details.)

REMOVE MEDIA WRINKLE
CONTINUE/CANCL PRINT

Meaning	Media wrinkles have been detected during print.
Action	Remove the media wrinkles and continue printing, or stop printing. (See Media wrinkles have been detected on  page 123 .)

(Print head error)

PH COOLING PROCESS
PLEASE WAIT

Meaning	The Printer operation was suspended, as the print head temperature exceeded 40°C. The print head temperature is always monitored by the Printer for the stable ink ejection.
Action	Secure the ambient temperature 15 to 30°C to prevent the print head temperature increase.

(Communication errors)

NO DATA RECEIVED
CHECK USB CABLE

Meaning	During the print data transfer, USB connection failure (cable disconnection) was detected.
Action	Check the USB cable connection.

NO DATA RECEIVED
CHECK HOST

Meaning	Though a timeout occurred during the print data transfer, it was not caused by a Printer failure.
Action	Check the USB cable connection.

(Other errors)

CLOSE COVER

Meaning	The front cover is open.
Action	You are advised to follow the message.

INK CHARGE NOT DONE
CHARGE INK SYS

Meaning	Cleaning or printing was started before charging the ink system completely.
Action	Charge the ink system completely before starting cleaning or printing.

MANUALLY ADJUST n
ADV VAL/PRINT POS

Meaning	Automatic print adjustment could not be performed.
Action	You are advised to follow the message. See Advanced Operation Guide, Automatic print adjustment cannot be performed on the  page 75 .

OPEN COVER TO ATTACH
SPITTOON CASE

Meaning	The spittoon case was not installed when the Printer was turned on or when the front cover was closed.
Action	You are advised to follow the message. See Carriage cleaning on the  page 77 .

ENV. TEMP. ERROR
CHANGE ENV TEMP

Meaning	The ambient temperature is not within the Printer's operating temperature range.
Action	Operate the Printer within the operating temperature range (15 to 30°C).

ERROR OCCURRED
PLEASE WAIT

Meaning	An error was detected during printing.
Action	Wait until the error message is displayed. If the error message is not displayed after five minutes, restart the Printer.

Out of ink while printing

While printing in online, the Printer allows the ink cartridge to be replaced without suspending the print operation.

When an ink cartridge is out of ink, the ink LED  goes off. You are advised to follow the message.

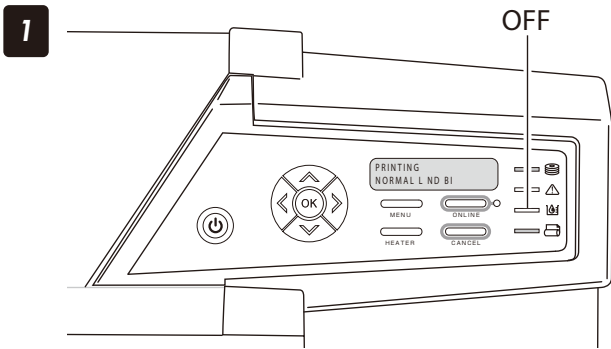

Ink LED  goes off.

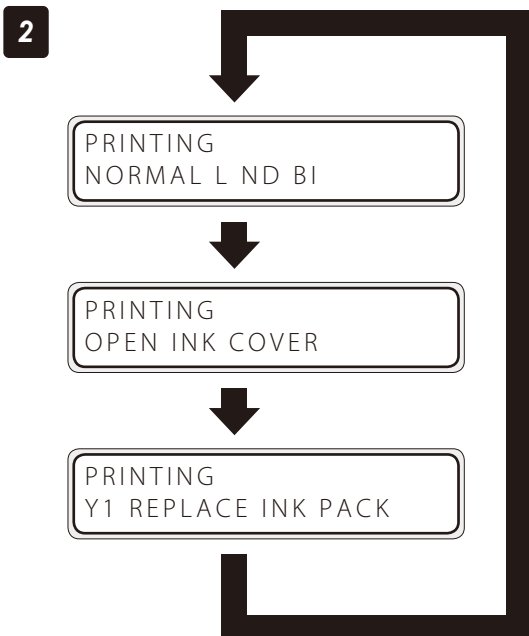

The message appears to prompt you to replace the ink cartridge.

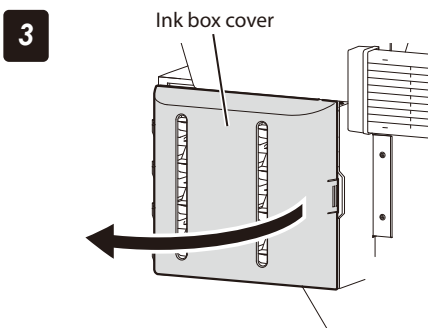

Open the ink box cover, and replace the ink cartridge.

See [Install and replace an ink cartridge](#) on the  **page 129**.

The media was skewed.

The Printer checks for media skew at every 3m print. If the Printer detects a skew exceeding the specified length, the print operation is suspended and a message appears on the operation panel so that you can select to continue or stop the print.

PRINTING
NORMAL L ND BI



The Printer checks for media skew.

MEDIA MISALIGNED
OK/CANCEL

Media skew was detected.

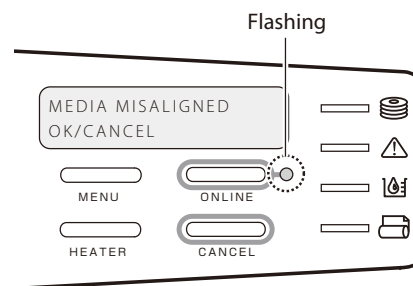

Continue printing with the OK button.



PRINTING
NORMAL L ND BI

Stop printing with the CANCEL button.



MEDIA MISALIGNED
RELOAD MEDIA



CANCEL is recommended.

- If you select **OK** to continue the print, the printing of the rest of the suspended job is started. However, it may happen that the media disengages from the media edge guards, or that a media jam occurs. When the printout is lengthy, the skew may also worsen, which may damage the Printer. Therefore, it is recommended to stop printing.

Media wrinkles have been detected

Using the safe scanning system, the Printer detects the media wrinkles during printing. When media wrinkles have been detected, the Printer enters the pause mode and a message appears on the operation panel so that you can select to continue or stop the print.



The Printer enters the pause mode when...

- The Printer enters the pause mode when safe scanning is set to **SUSPEND PRINTING** or **SUSPEND&WARNING**.

PRINTING
NORMAL L ND BI



(When media wrinkles have been detected)

REMOVE MEDIA WRINKLE
CONTINUE/CANCL PRINT

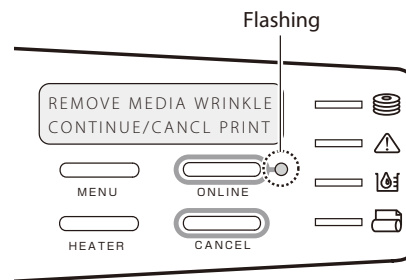

(When printing continues)

When the Printer is in pause mode, the front cover can be opened and closed and the pressure control knob can be operated without canceling the job being printed.

When you want to continue the printing, first remove the media wrinkles before resuming the print.

(When printing is canceled)

Stop printing with the CANCEL button.



MEDIA MISALIGNED
RELOAD MEDIA



When you continue the printing...

- If you select **CONTINUE** to continue the print, the printing of the rest of the suspended job is resumed. However, it may happen that the media wrinkles become bigger and that a media jam occurs. When the printout is lengthy, the media wrinkles may also become bigger, which may damage the Printer. Therefore, it is recommended to stop printing.

Open the front cover

CLOSE
COVER



Rotate the pressure control knob to set it to **Open**.



When rotating the pressure control knob...

- When you rotate the pressure control knob, hold the media with your hand so that it does not come up.

HOLD MEDIA



Remove the media wrinkles.



Rotate the pressure control knob to set it to **Normal**.

CLOSE
COVER



Close the front cover.



REMOVE MEDIA WRINKLE
CONTINUE/CANCL PRINT

Press the **OK** button to resume the printing.



PRINTING
NORMAL L ND BI

Warning messages

After the online printing, occasionally you may see one of the following messages appear on the operation panel display with the ERROR LED flashing  , which are warning messages. If so, follow the advice in the Recommendation column.

PERFORM DAILY
MAINTENANCE NOW

Meaning	The daily maintenance (cap cleaning) is not performed.
Action	You are recommended to perform the daily maintenance. See Daily maintenance on the  page 60 .

SERVICE NEEDED
CALL SERVICE

Meaning	The supply tube pump assembly needs to be replaced.
Action	You are recommended to ask your service representative to replace it.

LOAD INK PACK
CHARGE INK

Meaning	After the subcartridge's initial ink charge to the ink system, the ink tray has not yet started the ink supply to the ink system.
Action	Set the ink cartridges to the ink box's slots, and perform

PH RECOVERY
RECOMMENDED

Meaning	PH Recovery is recommended to prevent the missing dots problem.
Action	Perform PH Recovery.

PERFORM
PH RECOVERY NOW

Meaning	Automatic cleaning will be performed when the next printing will start.
Action	Perform PH Recovery. Perform PH Recovery in advance to skip this operation when the next printing will start.

PERFORM
SHEETMOUNT CLEANING

Meaning	Sheet mount cleaning has not been performed.
Action	Perform sheet mount cleaning.

REPLACE WIPER BLADE

Meaning	The wiper blades will need to be replaced soon.
Action	Replace the wiper blades.

REPLACE WIPER
CLEANING LIQUID

Meaning	The wiper cleaning liquid will need to be replaced soon.
Action	Replace the wiper cleaning liquid.

ADJUST MEDIA
ADVANCE VALUE

Meaning	Media advance value has not been adjusted.
Action	Adjust the media advance value.

ADJUST BIDIRECTIONAL
PRINT POSITION

Meaning	Bidirectional adjustment has not been performed.
Action	Perform bidirectional adjustment.

The Ink LED   blinks:

Meaning	Ink is running out.
Action	Prepare a new ink cartridge. See Install and replace an ink cartridge on the  page 129 .

Move the Printer

If you wish to move the printer several meters on the same site, across a horizontal floor with no steps and no slopes, see the following instructions.

For more difficult movement, contact your service representative.

- 1** Remove the media from the Printer.
- 2** Turn off the Printer.
- 3** Before the movement, loosen and raise the adjustment leveling feet so that the wheels touch the ground.
- 4** Push the printer to the preferred position.
- 5** After the movement, lower and tighten the adjustment leveling feet.

CAUTION

- Do not move the Printer with a media roll attached, or the heavy media may damage the Printer.
- Be sure to loosen and raise the adjustment leveling feet before movement, and lower and tighten them after movement.
- Move the Printer carefully so that the adjustment leveling feet would not hit against any obstructions.

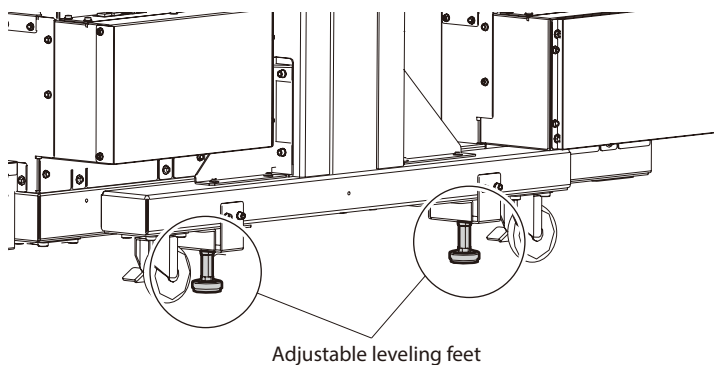

Replace a waste ink bottle

CAUTION

- Do not replace the waste ink bottle during printing.
- Replace the waste ink bottle carefully not to bump your head on the Printer upper part.
- Always use both hands to carefully remove and carry an OKI Data waste ink bottle to prevent the waste ink spilt on the Printer or on the floor.
- You are recommended to wear gloves when handling waste ink bottles.

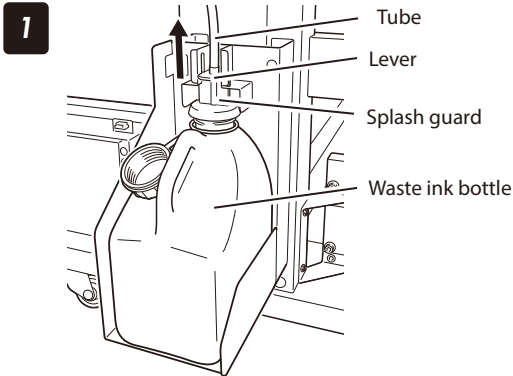

Slide the lever up and lift the splash guard sufficiently to remove the waste ink bottle.

The ink drips from the tube. Leave it for a while.

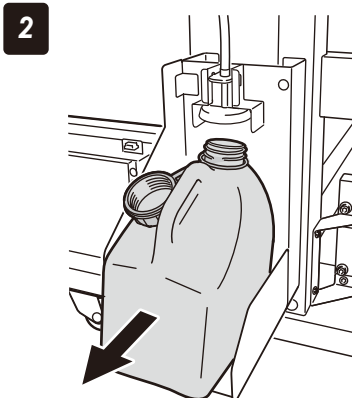

Carefully pull out the full waste ink bottle, taking care not to spill any on the printer or on the floor.

Securely close the cap on the waste ink bottle.

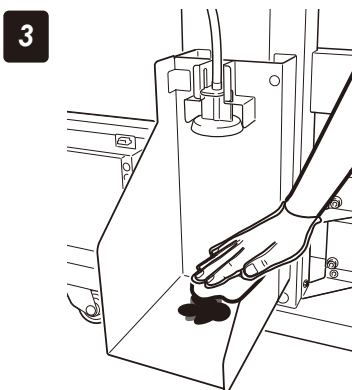

Wipe off the spilt ink in the waste ink bottle unit.

4

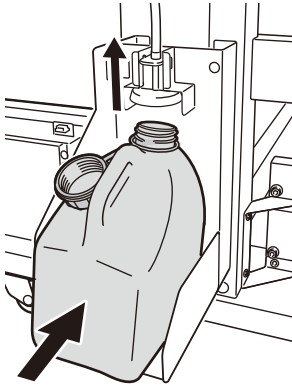

Slide the lever up and install a empty waste ink bottle.

5

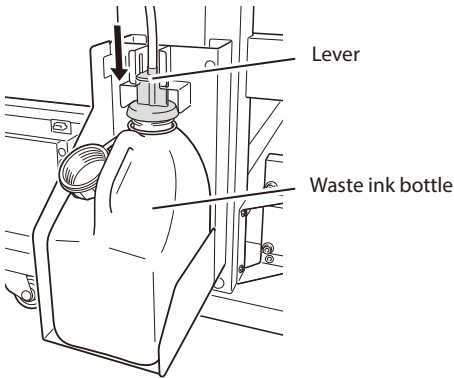

Lower the lever, and make sure that the splash guard was lowered.

Then the operation panel will request you to reset the waste ink counter.

6



On the operation panel, select **YES** and press the **OK** button to reset the waste ink counter.



If the waste ink counter is not reset...

- When the waste ink bottle is full, the Printer does not issue the message prompting you to replace the waste ink bottle. Then the waste ink overflows.

Install and replace an ink cartridge

At installing ink trays, be sure to insert each tray into its correct slot position of the ink box. Note that ink tray position is decided depending on its ink color.

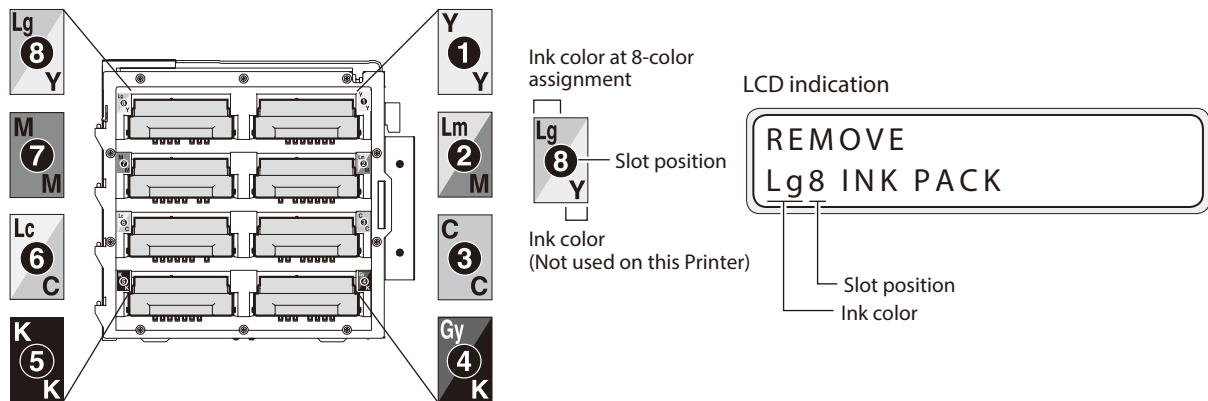

CAUTION

- Do not remove ink tray in the following cases. Otherwise, ink may spill in the Printer depending on the Printer state, which may damage the Printer.
 - The Printer is not powered on because the power was interrupted or because the circuit breaker turned off the Printer.
 - An error other than ink end has occurred.
- Do not touch the contact point in the ink cartridge's plate.

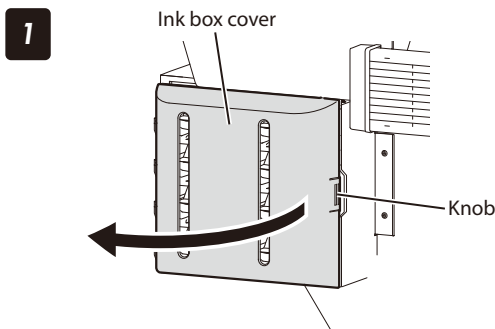

Push the knob of the ink box cover to open the ink box.

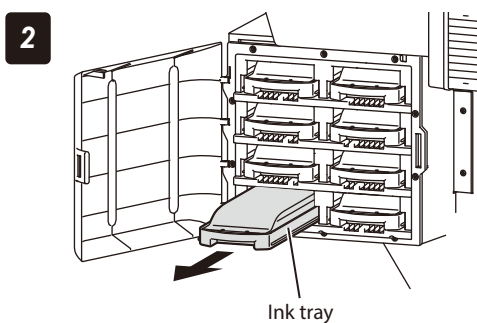

Confirm the color of the ink cartridge to be replaced, and pull its ink tray out of the Printer.

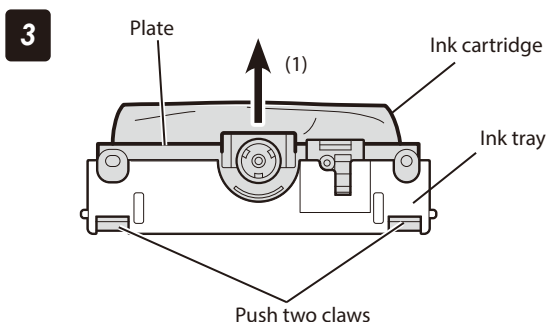

If no ink cartridge is installed on the ink tray, go to the step

4

Take the empty ink cartridge out of the ink tray.

(1) Push the two claws at the lower part of the the ink cartridge's plate, and pull up the plate.



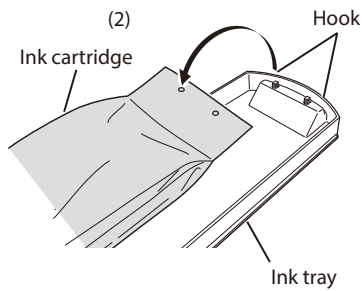

(2) Remove the ink cartridge from the hook of the ink tray.

4 Take a new ink cartridge out of the box and set it on the ink tray.

Hook the two holes (1) at the ink cartridge's end on the ink tray's two protrusion. Then insert the ink cartridge's plate part into the ink tray until you hear a click (2).

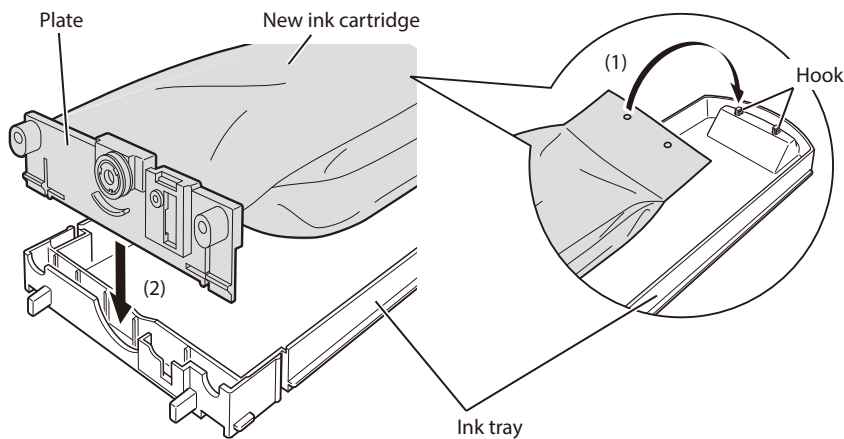

5

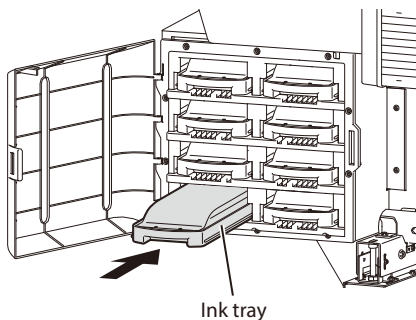

Insert the ink tray into the slot of the Printer.

Insert the ink tray as far as it will go.

6

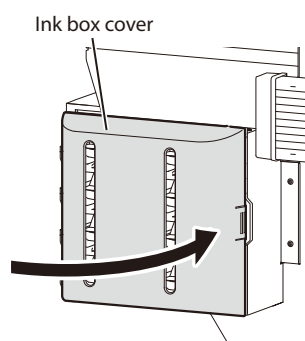

Close the ink box cover.

7

Confirm that the ink cartridge replacement was completed.

- When the replacement is successfully completed, the Printer returns to the online or offline state.
- If the replacement is not completed, an error message appears. Retry the replacement procedure beginning with step **1**.
- The print operation is performed even during the ink cartridge replacement, as far as the ink is remaining in the subcartridge.

Replace a wiper blade

The following section explains the procedure to replace the wiper blades.

The wiper blades must be replaced when you notice any damage during the daily inspection, or when a message prompting you to do so is displayed on the printer.

If the wiper blades are as shown below, replace them following this procedure.

Always replace the two blades together.

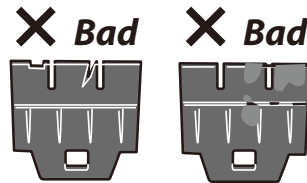

Prepare a pair of tweezers before starting the replacement procedure. (A pair of tweezers is included in the daily maintenance kit.)

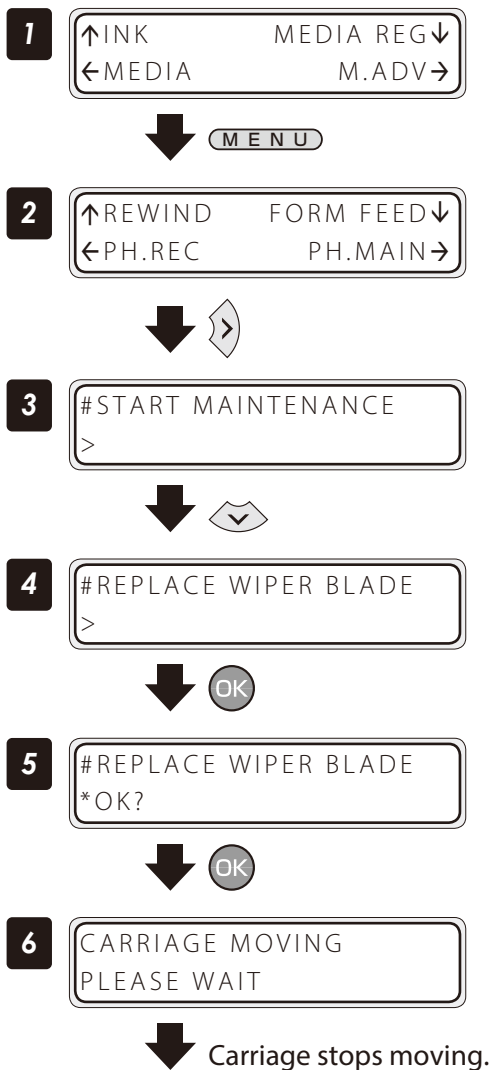

Set the Printer to offline state, and press the **MENU** button.

Press the **Right** button.

With the **Down** button select **#REPLACE WIPER BLADE**.

Press the **OK** button.

Press the **OK** button to execute the operation.
You may also press the **CANCEL** button to cancel the procedure.

7

OPEN COVER



8

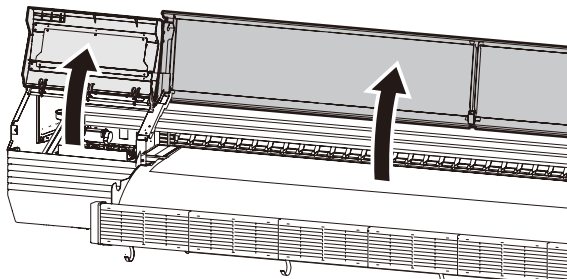

Open the front cover, and then open the wiping cover.

9

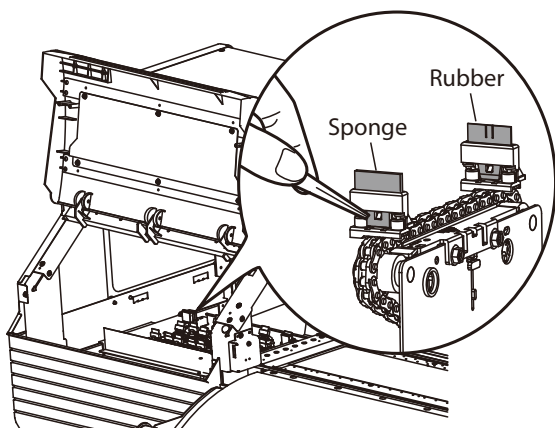

Hold the bottom edge of the wiper blade with the tweezers and detach the blade from the plastic protrusion.



10

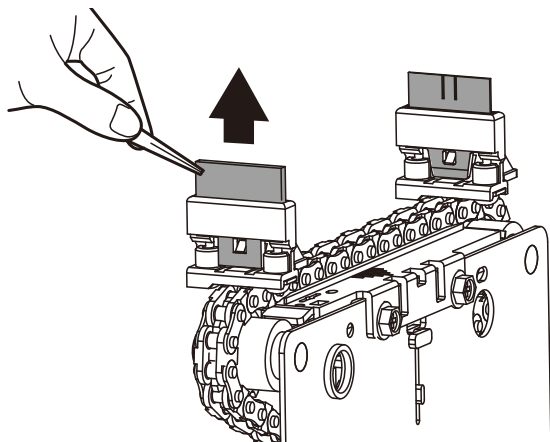

Pull the blade upward to remove it.

11

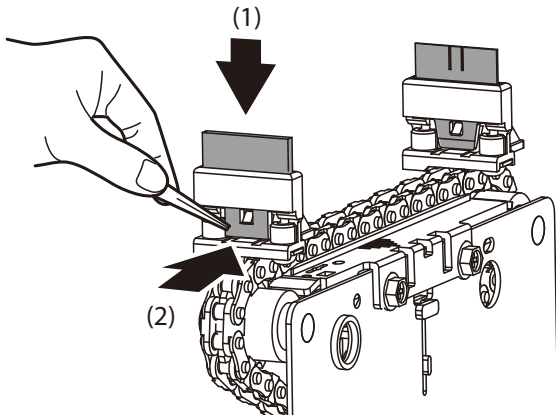

Hold the new blade using the tweezers and insert it straight from above. The hole in the rubber part at the bottom must hook to the plastic protrusion.

! CAUTION

- Install the wiper blades parallel as shown in the figure below. Pay attention to the order and the position of the blades.

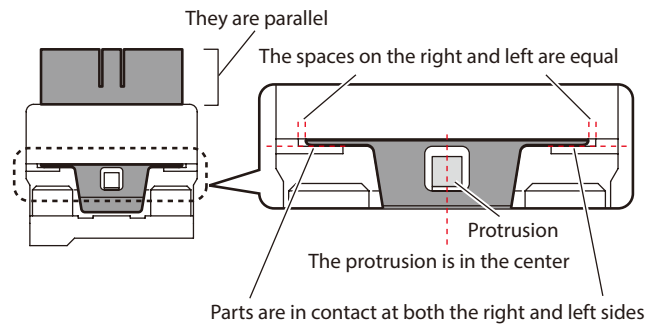
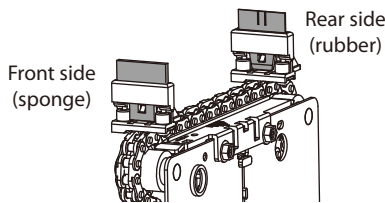

12

WIPERBLADE REPLACED?
YES: OK/NO: CANCEL

Press the **OK** button.



13

CLOSE COVER



14

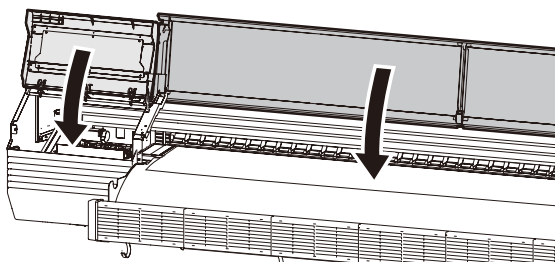

Close the wiping cover and the front cover.

! CAUTION

- Be sure to unlock the stopper before closing the capping cover. If you try to close the capping cover without unlocking the stopper, the stopper may bend, or the bent stopper may touch the carriage, which may damage the Printer.

15

CARRIAGE MOVING
PLEASE WAIT



Carriage stops moving.

#REPLACE WIPER BLADE
>

Replacing the wiper cleaning liquid

Replace the wiper cleaning liquid when the Printer displays a message prompting you to do so. The wiper cleaning liquid must be replaced approximately every 6 months.

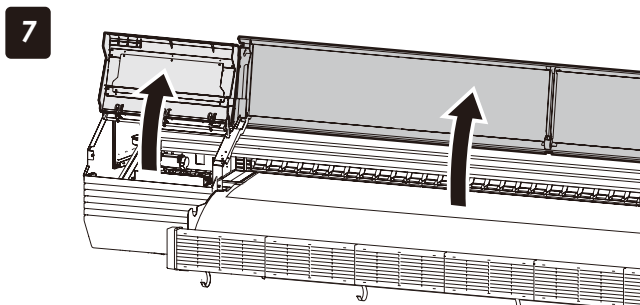

Set the Printer to offline state, and press the **MENU** button.

Press the **Right** button.

With the **Down** button select **#REPLACE WIPER LIQD**.

Press the **OK** button.

Press the **OK** button to execute the operation. You may also press the **CANCEL** button to cancel the procedure.

Open the front cover, and then open the wiper cover.

8

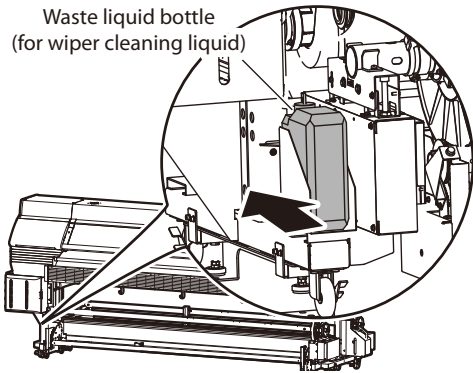

Check that a new waste liquid bottle (for wiper cleaning liquid) is installed.
 If no bottle is installed, remove the cap of a new waste liquid bottle (for wiper cleaning liquid) and install it in the wiping unit.

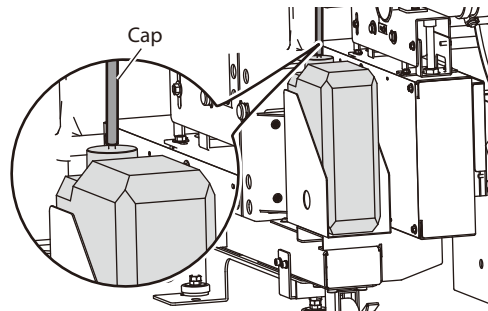

CAUTION

- Securely attach the cap with the tube to the waste liquid bottle (for wiper cleaning liquid).

9

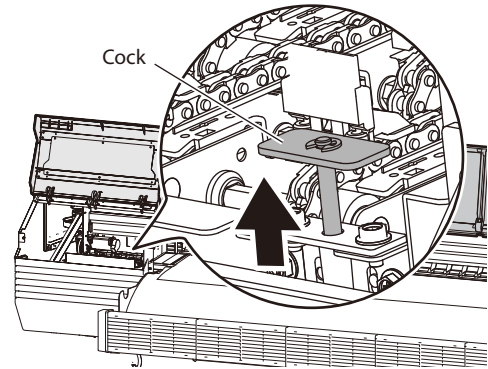

Pull the cock in the direction of the arrow to drain the wiper cleaning liquid.
 Wait until all the wiper cleaning liquid has been drained.

10

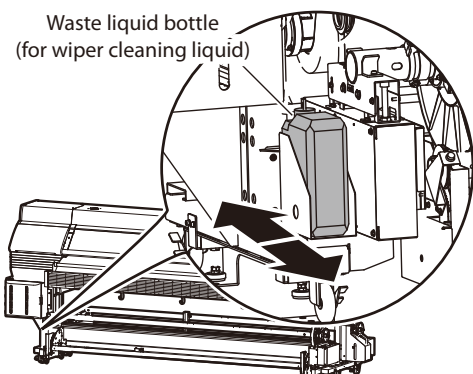

Confirm that all the wiper cleaning liquid has been drained, then remove the waste liquid bottle (for wiper cleaning liquid) from the wiping unit and install a new bottle.

11

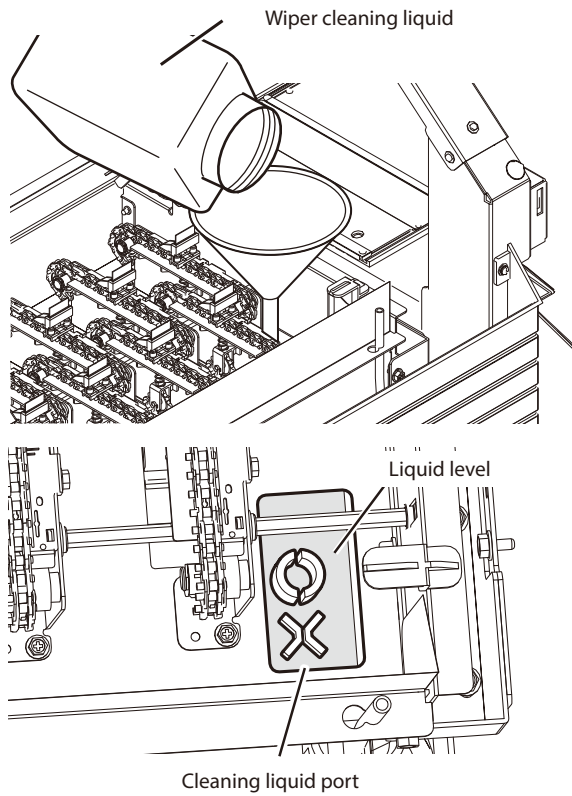

Supply wiper cleaning liquid.
 Pour the liquid until it reaches the top of the  mark.

12

WIPER LIQD REPLACED?
 YES: OK/NO: CANCEL



After the wiper cleaning liquid has been replaced, press the **OK** button.

13

CLOSE COVER



14

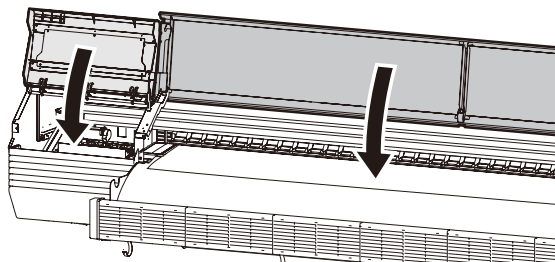

Close the wiping cover and the front cover.

 **CAUTION**

- Be sure to unlock the stopper before closing the capping cover. If you try to close the capping cover without unlocking the stopper, the stopper may bend, or the bent stopper may touch the carriage, which may damage the Printer.

15

CARRIAGE MOVING
 PLEASE WAIT

 Carriage stops moving.

#REPLACE WIPER LIQD
 >



Basic specifications

Item	Specification / Function
	IP-7900-22/23
Print method	Piezo-type color inkjet printing
Resolution	(main scanning direction) x (subscanning direction) 360dpi x 360dpi x DDP, 360dpi x 540dpi x DDP, 540dpi x 540dpi x DDP, 720dpi x 720 dpi, 900dpi x 900dpi
Print speed	17.6 m ² /h for 104-inch width at 12-pass NORMAL mode (depending on ambient temperature and print head temperature)
Media supply/takeup direction	Rear: Media supply side Front: Media take-up side
Media type	Vinyl, Banner, Mesh banner, Backlit banner (FF), Solvent printing coated paper
Media width	Max. 104 inches (2642 mm)
Ink cartridge	Normal solvent ink (8 colors) (black, cyan, magenta, yellow, light cyan, light magenta, gray, light gray) 1500 ml for each color
Interface	USB 2.0
Noise	Standby: 50 dB (A) or less Operating: 60 dB (A) or less (continuous sound) excluding supply/take-up motor noise and ink charging noise
Calorific power	15552KJ/H
Guaranteed print area	Area excluding top/bottom margins (5 mm) and right and left margins (5 mm) (When media edge guards are used, right and left margins are 10 mm.)
Power supply voltage	Printer power supply: 200 to 240 VAC, 6 A, 50/60 Hz Heater power supply: 200 to 240 VAC, 12 A, 50/60 Hz
Input power voltage range	Printer power supply: 180 to 260 VAC ±10%, 50/60 Hz ±1 Hz Heater power supply: 180 to 260 VAC ±10%, 50/60 Hz ±1 Hz
Power consumption	Printer power supply: 1440 W or less Heater power supply: 2880 W or less
External dimensions	4126 mm (W) x 1366 mm (D) x 1513 mm (H) ± 10 mm
Mass	600 kg or less (excluding media and ink)
Print ensuring temperature/humidity	20 to 25°C, 40 to 60%RH (no condensation)
Operating temperature/humidity	15 to 30°C, 30 to 70%RH (no condensation)
Storage temperature/humidity	5 to 35°C, 10 to 80%RH (no condensation)
Installation space (W) x (D) x (H)	Min. 4926 x 3366 x 2200 mm
Maintenance space (W) x (D) x (H)	Min. 7126 x 3366 x 2200 mm

Consumables

Ink cartridge

8-color ink One box contains one ink cartridge.

Type	Ink color	Quantity
IP6-221	Y (yellow)	1500 ml
IP6-222	M (magenta)	1500 ml
IP6-223	C (cyan)	1500 ml
IP6-224	K (black)	1500 ml
IP6-225	Lc (light cyan)	1500 ml
IP6-226	Lm (light magenta)	1500 ml
IP6-227	Gy (gray)	1500 ml
IP6-228	Lgy (light gray)	1500 ml

The type number may vary depending on the region. Contact your dealer for more information.

WARNING

- The ink is combustible. Keep the ink away from open flames, sparks, or other sources of ignition.
- Do not swallow ink or avoid its splashes on the eye to prevent breathing trouble or visual impairment. If ink gets into the eye, wash it off with clean running water and consult a doctor. If it is swallowed, do not try to vomit it forcefully, but consult a doctor.

CAUTION

- Always use OKI Data specified ink cartridges. Failure to use the recommended ink cartridge may lead to a deterioration of the print quality or a printer malfunction. This may invalidate your warranty.
- The ink validity period is 18 months from the date of production.
- Do not shake these ink cartridges before using them.
- Install ink cartridges and ink trays to all the 8 slots. When you remove ink cartridges or ink trays, be sure to install new ones instead.

Waste ink bottle

Type	Content	Quantity
IP6-109	Waste ink bottle	1 piece

Waste liquid bottle (wiper cleaning liquid)

Type	Content	Quantity
IP5-229	Waste liquid bottle	1 piece

WARNING

- The waste ink is combustible. Keep the waste ink bottle containing the waste ink away from open flames, sparks, or other sources of ignition.
- Do not swallow ink or avoid its splashes on the eye to prevent breathing trouble or visual impairment. If ink gets into the eye, wash it off with clean running water and consult a doctor. If it is swallowed, do not try to vomit it forcefully, but consult a doctor.

CAUTION

- A waste ink bottle must always be installed. When it is removed to dispose of waste ink, another empty waste ink bottle must be installed.

Daily maintenance kit A

Type	Content	Quantity
IP7-230	Cap cleaning liquid A	300 ml
	Wiper cleaning liquid A	200 ml
	Spittoon absorber liquid A	100 ml
	Dropper	10 pieces
	Cleaning swab	10 pieces
	Cleaning swab (thick)	30 pieces
	Tweezers	1 piece
	Spittoon case	1 piece
	Gloves	30 pieces
	Bag	1

WARNING

- Do not swallow cleaning liquid or avoid its splashes on the eye to prevent breathing trouble or visual impairment. If cleaning liquid gets into the eye, wash it off with clean running water and consult a doctor. If it is swallowed, do not try to vomit it forcefully, but consult a doctor.

Cap cleaning liquid A

Type	Content	Quantity
IP6-272	Cap cleaning liquid A (300 ml)	1 bottles

Wiper cleaning liquid set A

Type	Content	Quantity
IP7-231	Wiper cleaning liquid A (300 ml)	3 bottles
	Funnel	1 piece

Cleaning swab

Type	Content	Quantity
IP6-147	Cleaning swab	300 pieces
	Bag	6 pieces

Cleaning swab (thick)

Type	Content	Quantity
IP7-264	Cleaning swab (thick)	120 pieces

Storage liquid kit A

Type	Content	Quantity
IP7-237	Storage liquid pack A	8 pieces
	Dummy subcartridge	8 pieces

Cleaning liquid kit A

Type	Content	Quantity
IP7-236	Cleaning liquid pack A	8 pieces
	Dummy subcartridge	8 pieces

Sheet mount cleaning starter kit A

Type	Content	Quantity
IP7-225	Cap cleaning sheet	12 sheets
	Head cleaning sheet	12 sheets
	Sheet mount cleaning liquid A (100 ml)	3 bottles
	Dropper	3 pieces
	Gloves	24 pieces (12 pairs)

Spittoon absorber liquid A

Type	Content	Quantity
IP7-232	Spittoon absorber liquid A (300 ml)	3 bottles

Subcartridge

Type	Content	Quantity
IP7-211	Y (yellow)	400 ml
IP7-212	M (magenta)	400 ml
IP7-213	C (cyan)	400 ml
IP7-214	K (black)	400 ml
IP7-215	Lc (light cyan)	400 ml
IP7-216	Lm (light magenta)	400 ml
IP7-217	Gy (gray)	400 ml
IP7-218	Lgy (light gray)	400 ml

Wiper blade

Type	Content	Quantity
IP7-233	Rubber blade	8 pieces
	Sponge blade	8 pieces

Spittoon case set

Type	Content	Quantity
IP7-167	Spittoon case	4 piece
	Spittoon unit (two parts)	1 piece
	Tube	1 piece
	Bag	1 piece

Ink tray

Type	Content	Quantity
IP7-123	Ink tray	1 piece

Glove set

Type	Content	Quantity
IP7-138	Gloves	100 pairs

Absorbent sponge (Option for mesh banner)

Type	Content	Quantity
IP7-127	Absorbent sponge	10 pieces

Absorbent sheet (Option for mesh banner)

Type	Content	Quantity
IP7-124	Absorbent sheet	1 roll

Exhaust fan filter

Type	Content	Quantity
IP7-028	Exhaust fan filter	60 pieces

Dust filter

Type	Content	Quantity
IP7-027	Dust filter	1 roll

Options

Exhaust attachment (IP7-013)

An optional unit to attach an exhaust duct to the Printer

The recommended flow of air is as follows.
1.2 to 1.8 cmm (air velocity 3.0 to 4.5 m/s)
* cmm = cubic meter per minute

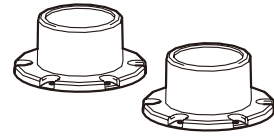

Mesh printing kit (IP7-011)

Used to print unbacked mesh banner.

Footswitch (IP7-014)

The footswitch allows you to operate the take-up reel unit by foot. This improves work efficiency.

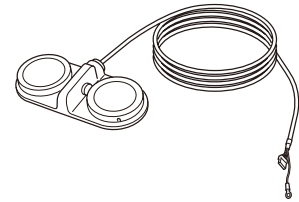

(Footswitch connected to the take-up reel unit)

- Use the take-up direction switch on the take-up reel unit of the printer to set inner take-up or outer take-up.
- The black switch of the footswitch has the same function as the take-up reel switch (black) of the take-up reel unit. Press the black footswitch to take up media to the take-up scroller.
- The white switch of the footswitch has the same function as the media feed switch (white) of the take-up reel unit. Press the white footswitch to feed media from the take-up scroller.

(Remark)

- Attaching footswitches do not increase power consumption.

CAUTION

- Do not use footswitches in a humid place or a place exposed to water to prevent a failure.
- Do not connect or disconnect the footswitch with wet hand to prevent a failure.
- When ink adheres to the footswitch, remove it immediately. If the footswitch is left with ink for a while, the switch surface may be damaged.
- Hold the connector of the footswitch cable when connecting or disconnecting the footswitch. Pulling the cord of the cable may result in disconnection or poor contact of the connector.
- Be sure to connect the ground lines. Otherwise, a malfunction or failure due to noise may be caused.
- Do not press the footswitch strongly. This may cause a failure of the switch part.
- Do not put anything on the footswitch cable. Doing so may result in disconnection or other failure.

■ Installation

CAUTION

– Turn off the power switch of the printer before installing the footswitch.

Plug the other connector of the footswitch in the connector of the take-up reel unit, and then screw the ground line.

Loosen the screw fixing the cable clamp to the printer. Then fix the cable with the cable clamp at the clamp's original position.

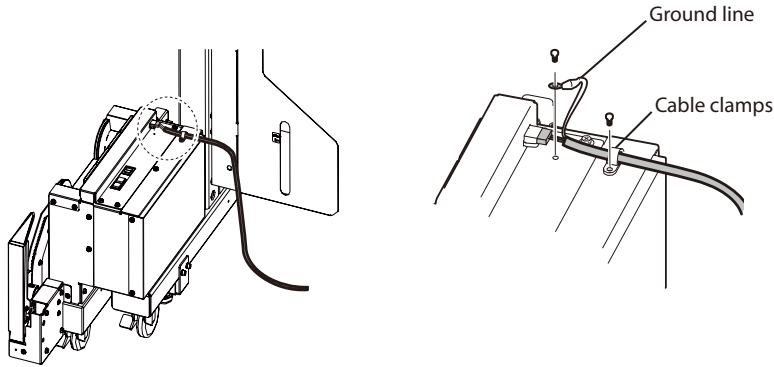

Scroller (IP7-015)

An optional scroller available for both the roll feed unit and take-up reel unit

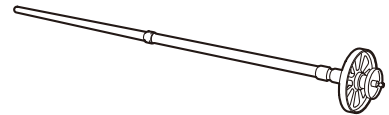

Tensioner 104 (IP7-023)

An optional kit to print on the lightweight banner

Offset loading kit 104 (IP7-025)

An optional kit to install media with the slide to the wiping unit direction

Index

A		G	
absorbent sheet	140	glove set	140
absorbent sponge	140		
afterheater	20		
B		H	
backlit banner (FF)	23, 50	head cleaning	
banner	23	Normal cleaning	100
buzzer	20		
C		I	
cap cleaning liquid set	140	inner take-up	41
capping cover	18	ink pack	
capping unit	19	replacement	129
capping unit side	12	Ink box cover	18
cleaning	95	ink tray	19, 140
carriage	19		
caster	18	L	
cleaning liquid kit	140	LCD	20
cleaning swab	140	LED	20
		LOOSE winding mode	52
D		M	
daily maintenance	60	media	
daily maintenance kit	139	available printing area	11
double-sided printing	56	jammed	24, 115
		unloading	44
E		media advance/rewind switch	18
error message	116	media drying fan	18, 45
exhaust attachment	141	media edge guard	19, 34
		mesh banner	23
F		mesh printing kit 74	141
fixing ring	38	move the Printer	126
flange holder	18		
flange shaft fixture	32	N	
front cover	18	nozzle print	101

O

outer take-up	41
online	21
offline	21
operation panel	20
operator call error	117

P

peel roller	38
platen	19
paper tube	39
power switch	20
preheater	20
pressure control knob	18
printer heater unit	20
printhead	20
protection bar	18

R

roll spacer	32
-------------------	-----------

S

scroller flange	32, 142
service call error	116
shaft cover	18
skew	122
solvent printing coated paper	23, 50
spittoon absorber liquid	81
spittoon absorber liquid set	140
spittoon case	19
spittoon case set	140
storage liquid kit	140
subcartridge	19, 140
subcartridge cover	18
scroller shaft	32

T

take-up direction switch	18
tension bar	18
tension bar guide	18, 42
tension bar flange	38
tension bar flange with screw	37

U

USB cable	28
USB connector	18

V

vinyl	23, 50
-------------	---------------

W

warning message	125
waste ink bottle	139
replacement	127
wiper blade	140
replacement	131
wiper cleaning liquid	
wiper cleaning liquid set	140
wiping cover	18
wiping unit	19
wiping unit side	12

